

# TOSTEM

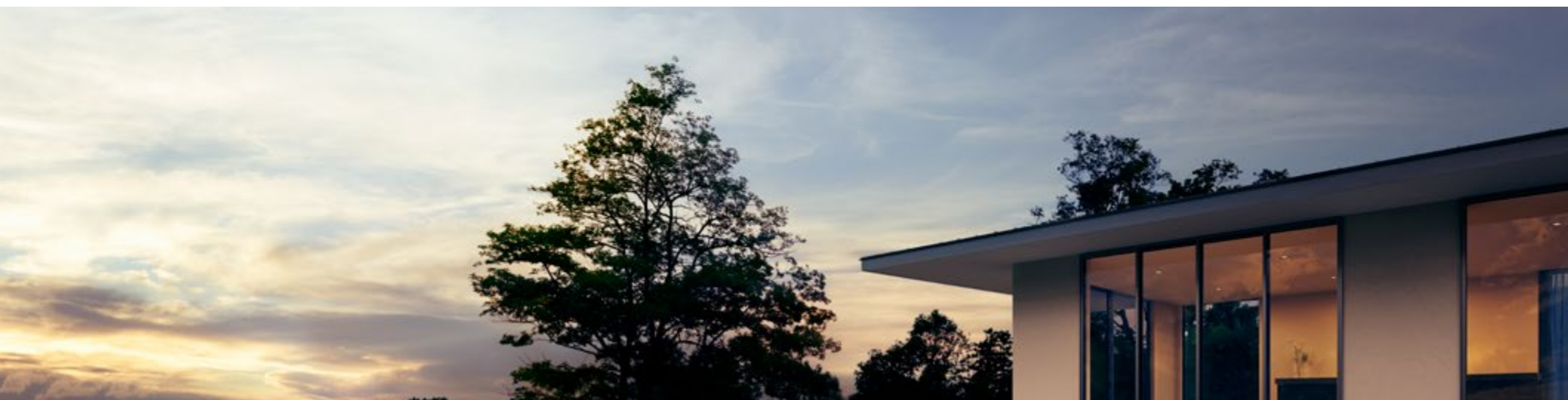

FRAMING THE BEAUTY OF LIVING

---



# CONTENT

CORPORATE PROFILE	04
100 YEARS OF WISDOM	06
NEW ALUMINUM COLOR DUSK GRAY	07
INNOVATION FOR HOME & LIVING INSPIRATION	08
DESIGN FOR GOOD LIVING SPACE	10
QUALITY DESIRED BY HOME RESIDENT	12
HARMONY WITH THE ENVIRONMENT	14
TOSTEM TOTAL HOUSING SOLUTION	16
TOSTEM WINDOW AND DOOR SERIES	18
GRANTS SERIES	20
ATIS SERIES	36
WE SERIES	56
INTERIOR SERIES	76
ENTRANCE DOOR	82
GIESTA AIRFLOW	94
ALUMINUM EXTERIOR	100
REFERENCE DRAWINGS	110

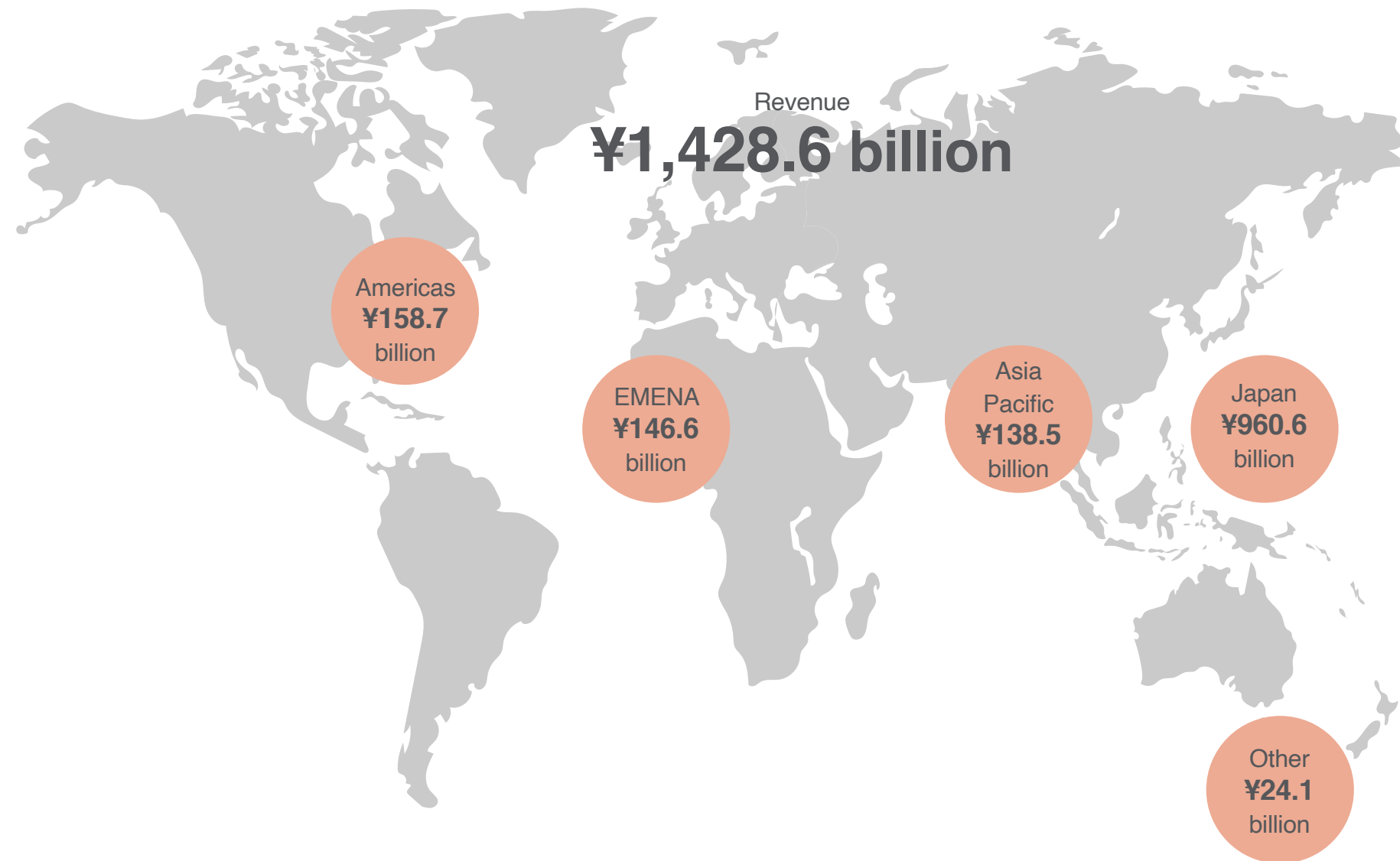

People using our products:

**over One billion**

**100+**

YEARS OF HISTORY  
1875 >>> 2023

Employees Approx.

**55,000**

**13,000+**

PATENTS/  
DESIGN RIGHTS OWNED

Factories

**79** in **10** markets

**15**

NUMBER OF  
PRODUCT BRANDS

showrooms

**111** in **16** countries

# Making better homes a reality for everyone, everywhere

## LIXIL GROUP

A better home is made up of surprisingly simple things – showers and faucets to experience water in new ways; kitchens that unleash creativity; toilets that provide cleanliness and comfort; doors and windows that connect you with the world outside; interiors and exteriors that bring spaces to life; baths to escape in after a long day. We make that possible with pioneering water and housing products. We are proud that our products touch the lives of more than a billion people every day, and believe we have the potential to do so much more.

LIXIL's Purpose is the north star that guides our employees in making decisions and inspires us to become a more agile, entrepreneurial company for sustainable growth. The LIXIL Behaviors are how we engage in our work every day to realize our Purpose. Together, they form the heart of our Corporate Philosophy.



TOSTEM

American Standard



INAX





TOSTEM, a leading global brand of windows and doors, is a part of Japan's LIXIL Group. TOSTEM has achieved a significant milestone of 100 years in the industry, marked by its commitment to creating exceptional living spaces that connect people to nature.

The company was founded in 1923 by Takejiro Ushioda as Myokenya Shoten, a wooden fittings retail business, which later expanded to designing and manufacturing aluminum sash windows in 1966. Over the years, TOSTEM has evolved to meet changing customer needs, continuously enhancing the performance and comfort of homes with their durable and high-quality products.

The company's innovations have made a significant impact on the housing industry, with several firsts to their credit.

TOSTEM has now embarked on a new era, where they aim to create responsive window designs that connect people and nature, transforming the art of living inside-out and outside-in.

One Century of Experience.  
One Century of Passion.  
One Century of Wisdom.

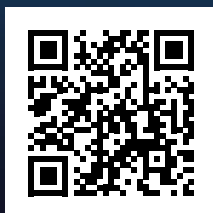

## new aluminum color DUSK GRAY

The sun enhancing the scenery, set far away on the horizon. The afterglow of the sky gradually deepens, and the houses blend in with the scenery.

Why is this overlap of ambiguous colors bringing peace of mind? Why we are attracted to the beauty of this color?

Connecting people and nature through windows and doors. Introducing the new color "DUSK GRAY" that blends in and complements your lifestyle.

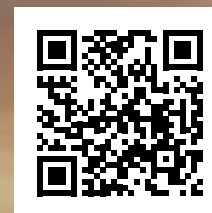



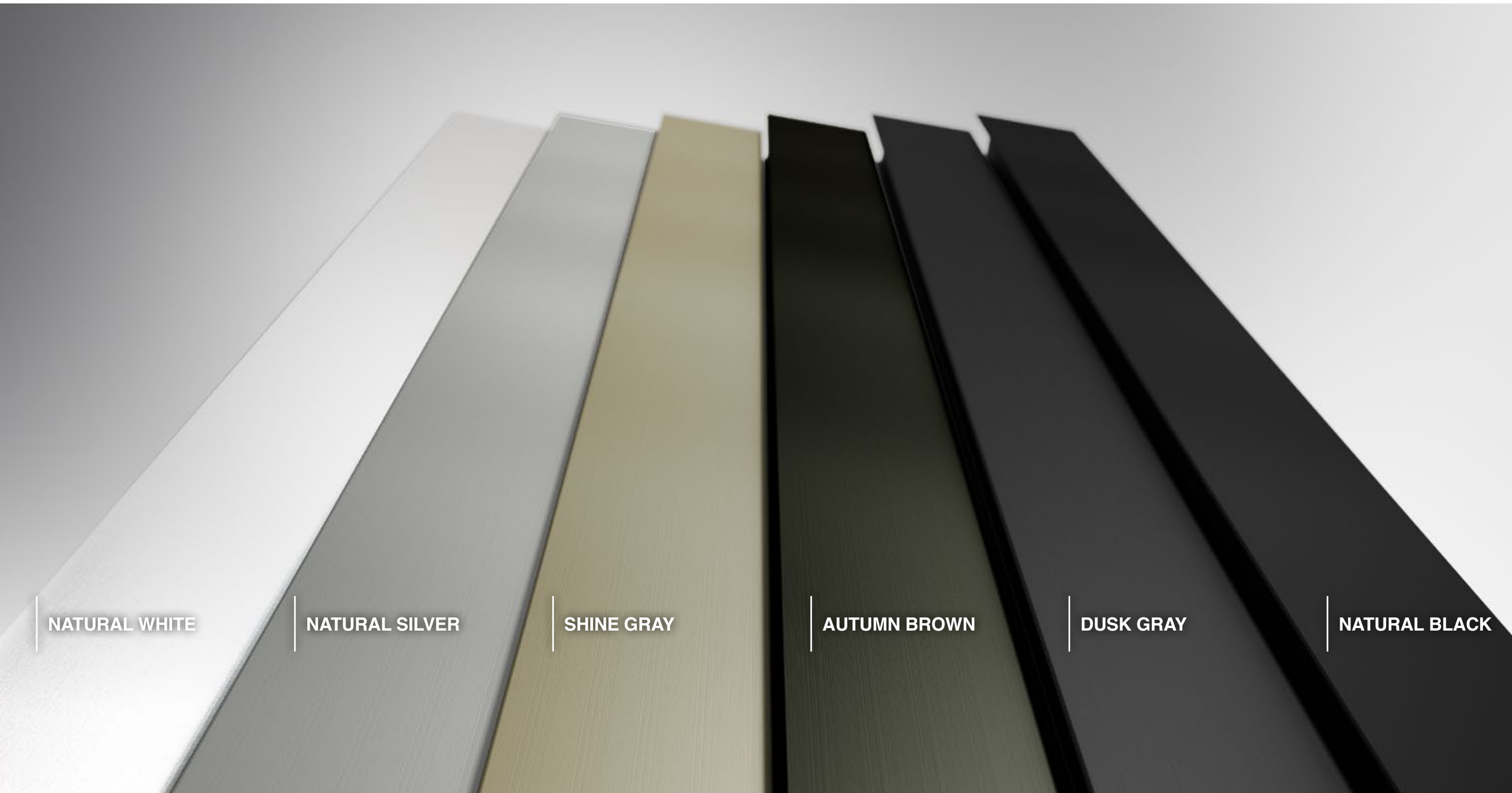

NATURAL WHITE

NATURAL SILVER

SHINE GRAY

AUTUMN BROWN

DUSK GRAY

NATURAL BLACK

## Innovation for home & living inspiration.

With people and their better quality of living at our core, we are constantly aware of how they live, by anticipating social change and needs of time. We continually pursue innovation that makes good living a reality for all.

TOSTEM's unique TEXGUARD anodized finish gives a high level of protection, alongside showing the beautiful appearance of natural Aluminum. TOSTEM offers a wide range of color variations, which allows you to enjoy its lifelong beauty, adding happiness to your lifestyle.

### BENEFIT OF TEXGUARD

**Color retention** - TEXGUARD protect the Aluminum against harsh environmental conditions, making the color gloss stay for at least 40 years.

**Increased hardness** - Dense coating of TEXGUARD improve hardness and provides scratch resistance for the Aluminum surface.

**Ease of cleaning** - Dust and dirt accumulation resistance quality of TEXGUARD makes the task of cleaning the surface less effort.

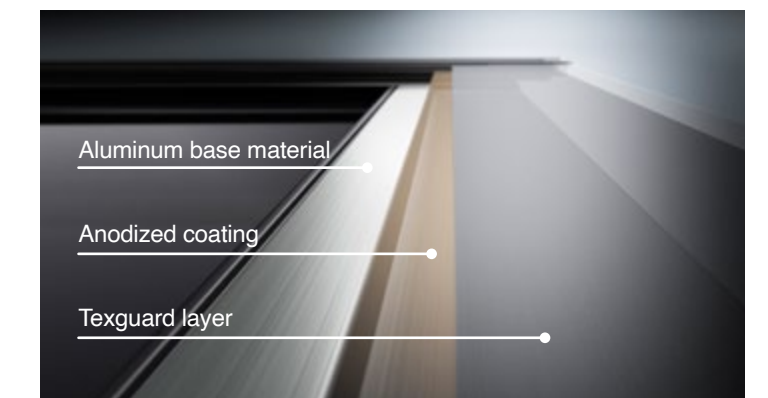

### Certification

JIS H 8602: 2010, JIS H 4100: 2015, TIS 218-2520 (1977), TIS 284-2560 (2017), AAMA 612, ISO 9001: 2015, ISO 14001: 2015, ISO 17025: 2018



## Design for good living space.

|

We know that home can be and mean so much for people. We design our product to enhance the quality of a space allowing home residents to be connected, to be inspired and to feel comfortable through the harmonious experience to outside.

### L-FIT DESIGN

L-Fit is a handle design that “Fits” in with “Living Life.” This standardized design for the handles of windows and entrance doors creates a sense of uniformity and comfort in living space.

L-Fit has been recognized with multiple design awards including the prestigious German Design Award, Red Dot Award, Good Design Award and iF Design Awards.

Experience the perfect combination of design and function with TOSTEM L-Fit.



reddot winner 2022





# Quality desired by home resident.

We consider to ensure quality through the entire process and usage, from the product design development and production. With responsibility and pride, we pursue our production with a commitment to deliver the best quality for all home residents.

## QUALITY ASSURANCE

Quality assurance is at the core of TOSTEM's products. Japan is renowned for its rigorous quality control systems, which ensure that products meet international standards such as the Japanese Industrial Standard (JIS) and ASTM International. Tests include water penetration, sound insulation, air leakage, structural performance, durability, environmental, light irradiation, and sunshine weather testing.

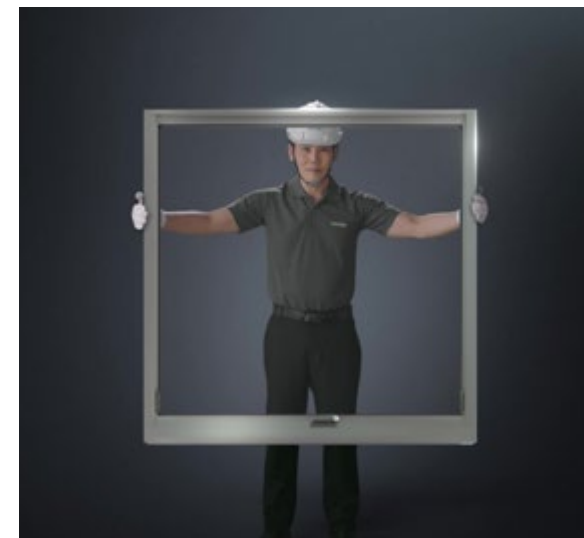
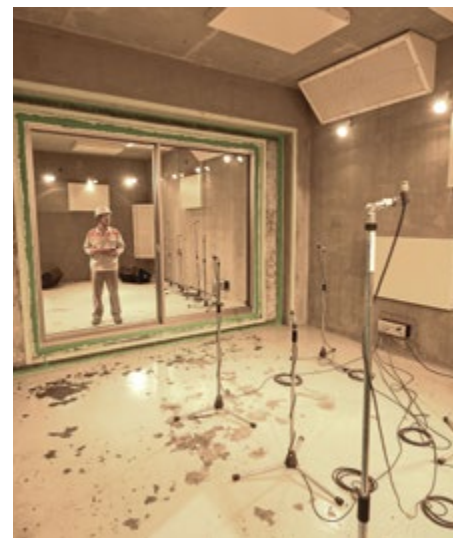
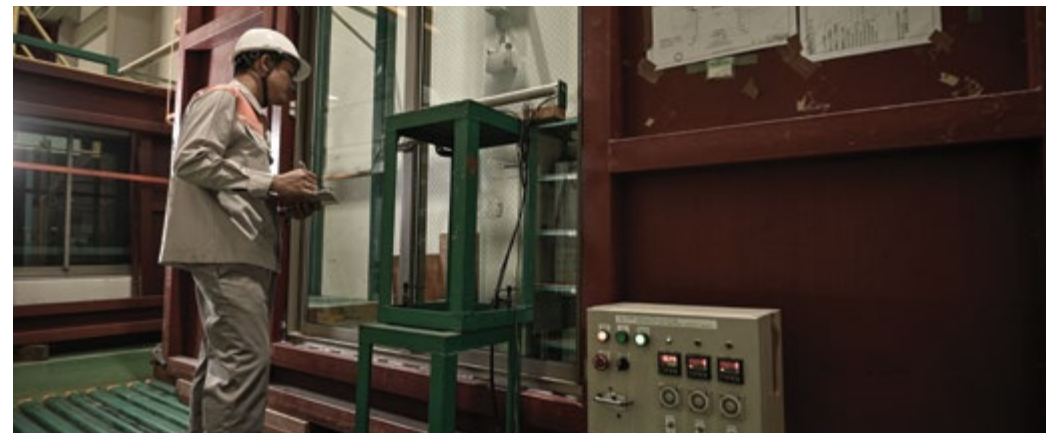

## PRE-ENGINEERED SYSTEM

TOSTEM's products are designed, manufactured, and assembled using a pre-engineered system that strictly adheres to quality control standards. This system incorporates extrusion dies, aluminum billets, coatings, and hardware assembly processes that are all performed in TOSTEM's factory. The primary advantage of this system is the ability to achieve consistent quality in window production. With just a simple screwdriver, anyone can repeatedly build the same high-quality window system.





# Harmony with the environment.

We understand the continuous change in nature and climate of the world, the differences in location and space people live in. We exist to create harmony of living through functional performance and aesthetic design, ensuring comfortable living in variety of climates and environment.

## TOSTEM AIRFLOW SYSTEM

The perfect solution for a comfortable, harmonious, and safe home. Our high-quality airflow system is designed to provide optimal airflow, reducing indoor pollutants, and ensuring a healthier living space for you and your loved ones. With TOSTEM Airflow System, you can enjoy the benefits of natural ventilation, which helps regulate temperature and humidity levels, reducing the need for artificial cooling systems.

1  
GIESTA  
AIRFLOW



Close      Open

2  
AIRFLOW  
SLOT  
(available for  
WE 70)

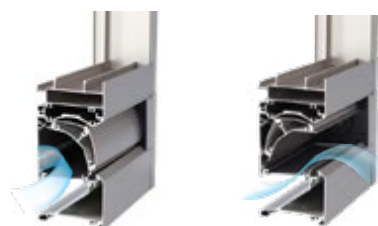

Close      Open

3  
AIRFLOW  
DOOR



Close      Open



# TOSTEM Total Housing Solution

TOSTEM engages in product development, manufacturing, and marketing of a diverse range of home products, such as window sashes, entrance doors, and exterior products. Our product portfolio allows us to provide complete "Lifestyle Solutions" that are flexible, integrated, and coordinated to consumer needs, delivering everyday satisfaction.

## ALUMINUM WINDOWS & DOORS

Let our aluminum windows and doors frame your world. Our windows and doors come in a variety of sturdy frames to offer you effortless maintenance, years of satisfied use and of course, a great view.

## ENTRANCE DOOR

GIESTA high quality wood-pattern or metallic finish door, equipped with user-friendly handle with high security lock system gives better convenience to both family and visitors and make us feel glad to be home.

## ALUMINUM EXTERIOR PRODUCTS



















FENCE & GATE is a perfect fencing choice for your residence. Our fence and gate solution will enhance the look, feel and overall value of your property, and provide you with the safety and security that your family needs.

## ALUMINUM INTERIOR DOOR

A luxurious and durable choice to divide interior living spaces. Slim design aluminum profiles give a modern accent to your space.



# TOSTEM Window and Door Series

		FRAME DEPTH, HEIGHT OF SILL	DESIGN	PERFORMANCE	GLASS APPLICATION	
GRANTS SERIES		GRANTS	Frame depth : 101.6 / 120 / 178 mm  Height of sill : 50 mm	Traditional Minimal 	Low-rise High-rise 	5 mm (SG) ~15mm (LG) ~32mm (IGU) 
ATIS SERIES		ATIS PLUS	Frame depth : 88 / 131.5 mm  Height of sill : 55 mm	Traditional Minimal 	Low-rise High-rise 	5 mm (SG) ~15mm (LG) ~32mm (IGU) 
		ATIS	Frame depth : 88 / 131.5 mm  Height of sill : 55 mm	Traditional Minimal 	Low-rise High-rise 	5 mm (SG) ~15mm (LG) ~32mm (IGU) 
WE SERIES		WE PLUS	Frame depth : 72 / 104 mm  Height of sill : 35 mm / 50 mm	Traditional Minimal 	Low-rise High-rise 	5 mm (SG) ~15mm (LG) ~32mm (IGU) 
		WE 70	Frame depth : 72 / 104 mm  Height of sill : 35 mm	Traditional Minimal 	Low-rise High-rise 	5 mm (SG) ~15mm (LG) ~32mm (IGU) 
		WE 40	Frame depth : 41 mm  Height of sill : 35 mm	Traditional Minimal 	Low-rise High-rise 	5 mm (SG) ~15mm (LG) ~32mm (IGU) 





## GRANTS series

|  
**MASTERING THE ART OF LIVING  
SPACE**

GRANTS series is designed and engineered to redefine boundary of living space. Unbound the view of the world with panoramic doors. With seamless and innovative designs that allow you to own the breathtaking view of the world.



# GRANTS

GRANTS is TOSTEM's flagship series. Its innovative design results in a larger surface area of glass for panoramic views. This takes the standard of Aluminum windows and doors to another level.

## SPECIFICATIONS

	GRANTS	GRANTS FLAT RAIL & CORNER SLIDING DOOR
FRAME DEPTH	101.6 MM 120 MM ( 2 TRACKS SLIDING ) 178 MM ( 3 TRACKS SLIDING )	120 MM ( 2 TRACKS SLIDING ) 178 MM ( 3 TRACKS SLIDING )
HEIGHT OF SILL	50 MM	



## COLOR



## PERFORMANCES

	WIND PRESSURE	WATER TIGHTNESS	AIR TIGHTNESS	NOISE INSULATION
GENERAL GRANTS PRODUCT	2000PA (ASTM E330)	300PA (ASTM E300)	10.7M3/H-M2 (ASTM E283)	T-1: 25DB (JIS)
FLAT RAIL SLIDING DOOR	S-1: 500PA (JIS A1515)	W-2: 150PA (JIS A1517)	A-4: 2 (JIS A1516)	T-1: 25DB (JIS)
CORNER SLIDING DOOR	S-1: 500PA (JIS A1515)	W-2: 150PA (JIS A1517)	A-4: 2 (JIS A1516)	T-1: 25DB (JIS)

## A PERFECT BALANCE OF LIFE'S PERSPECTIVE

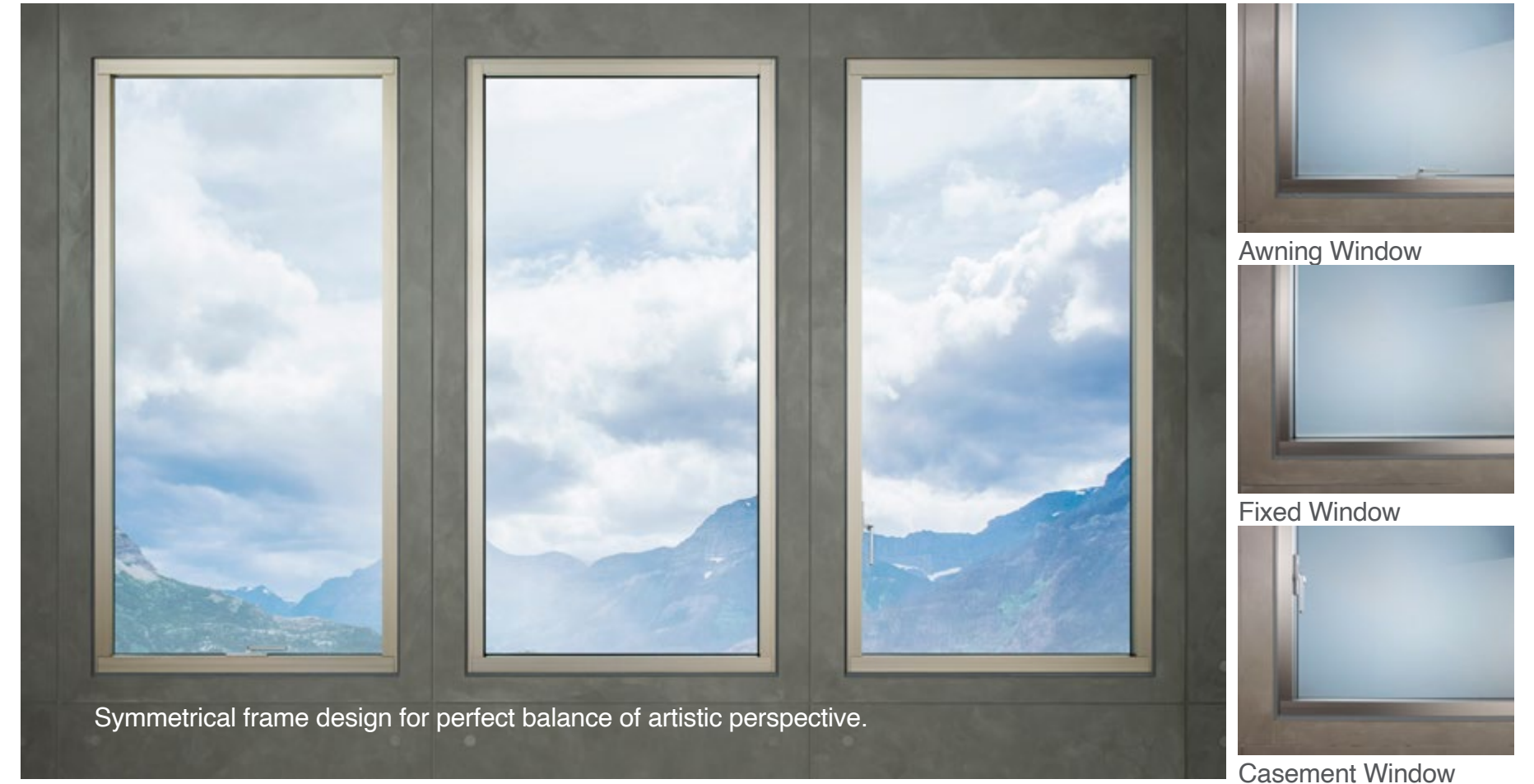

Symmetrical frame design for perfect balance of artistic perspective.

## LESS FOR MORE

Integrated screen system provides less obstructed vision for better view.

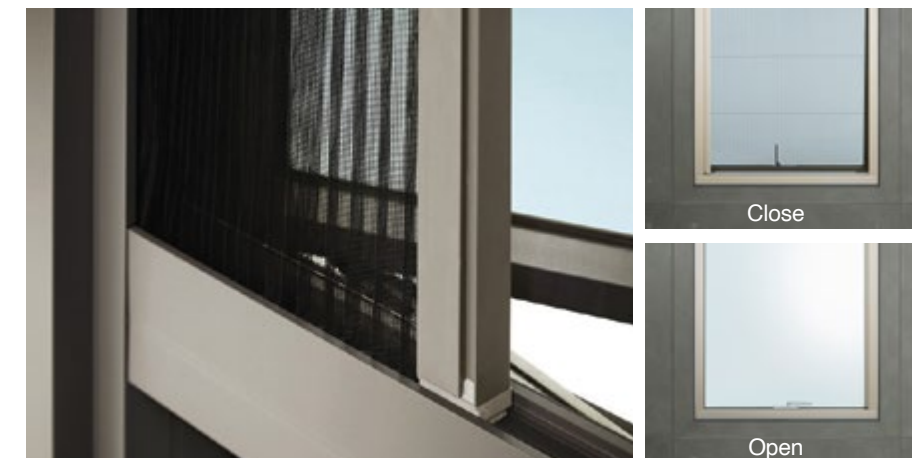

Integrated insect screen system combines the best functions to provide obstruction free vision for better view. The insect screen is also designed to be easily removed for maintenance and cleaning.

## PERFECT FIT

L-Fit is designed to fit every living style. Create for the most comfort feeling that comes with advanced design and function



\*For casement and awning window



**NEW**

# GRANTS

Bonding harmony with the environment, GRANTS Flat Rail Sliding Doors come in vast size up to 4.5 meters high that allow you to own a breathtaking view.



**HEIGHT  
UP TO  
4.5 METERS**

## ABSOLUTE SEAMLESSNESS

Sophisticate design that maximize your view with overlapping design that visually reduce stile by half.



## BUILD FOR BOUNDLESS

Flat sill rail designed for cleanness and smoothest transition between inside and outside.

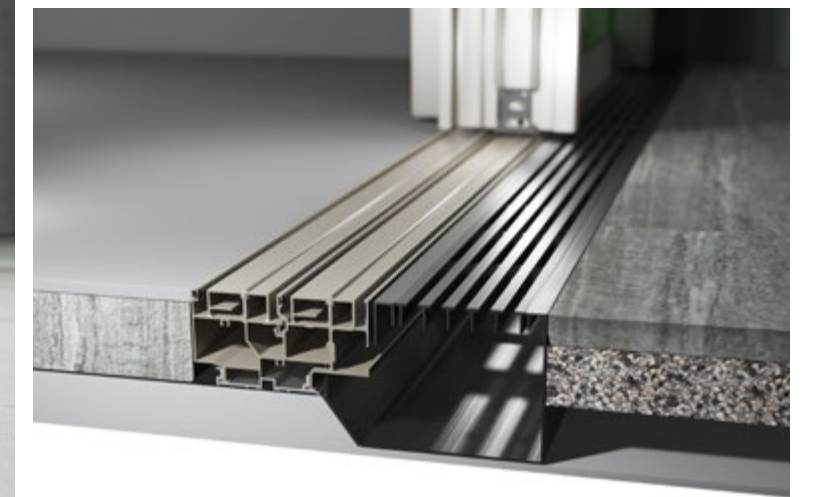



NEW

# GRANTS CORNER SLIDING DOORS

An innovative solution creates unrestricted panoramic views and the ultimate living space with an open corner



## LIMITLESS BEAUTY OF YOUR SPACE.

GRANTS corner sliding doors allow you to open an entire corner of a room to the outside. Perfect for open plan living, maximizing light for spacious space.

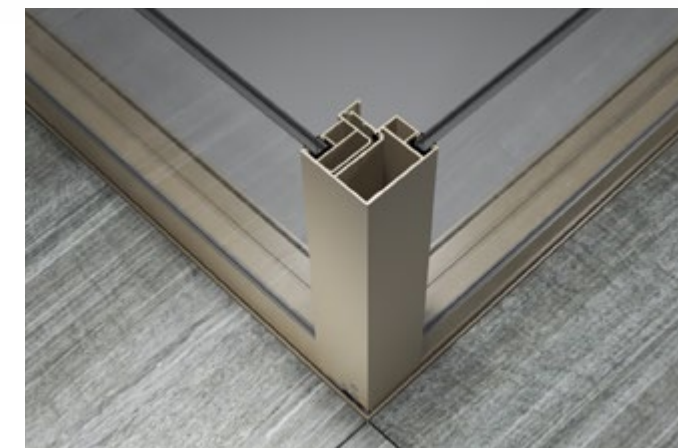
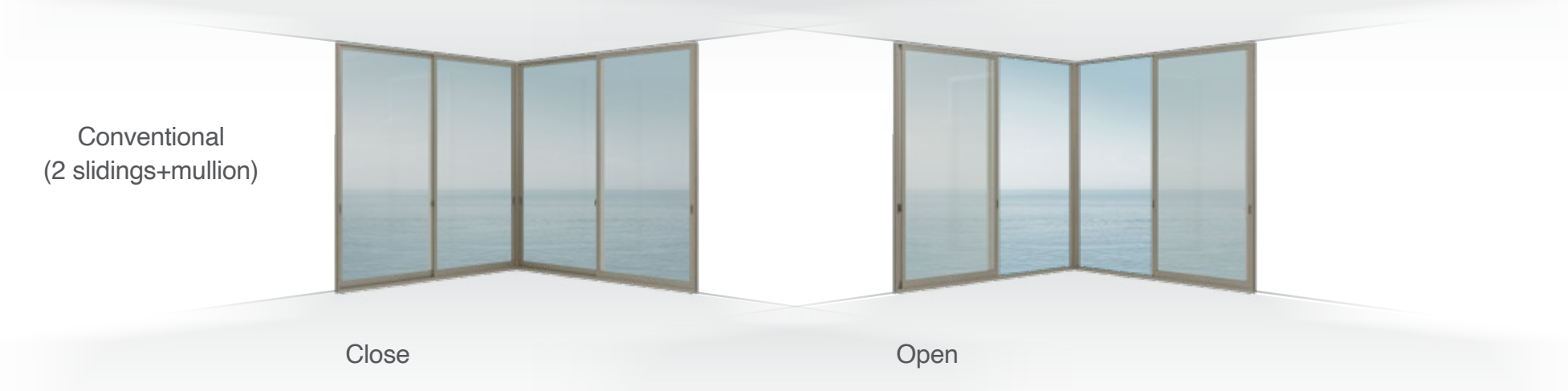
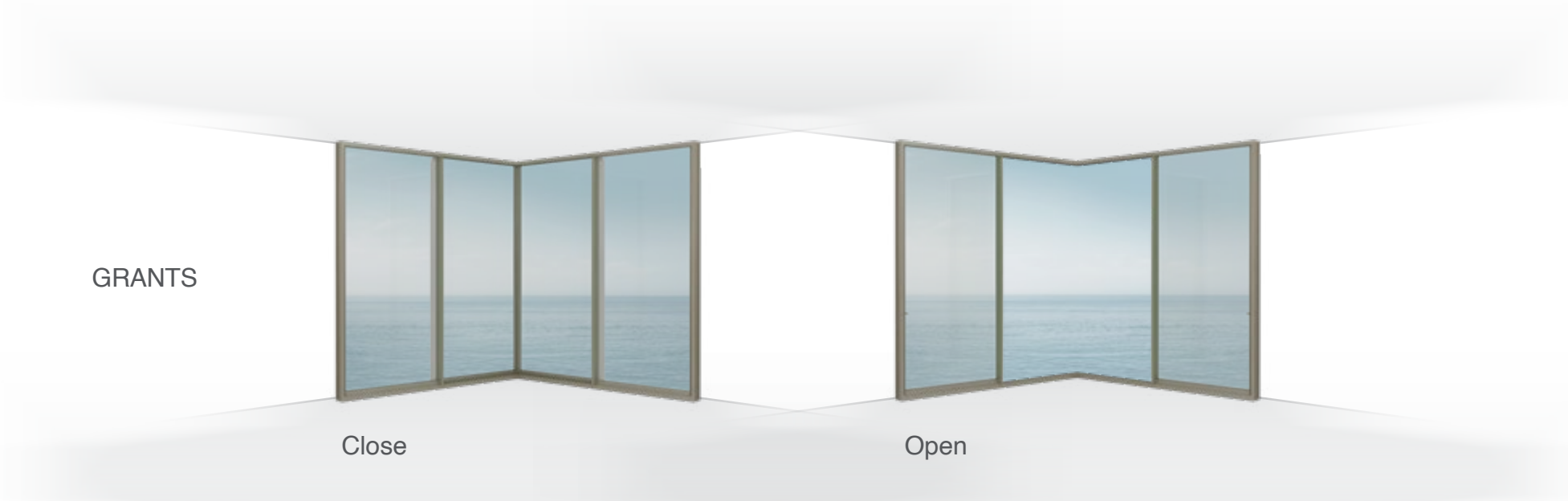

Close

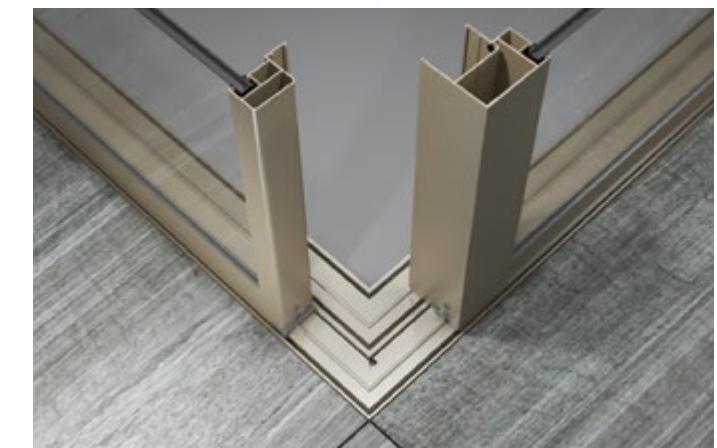

Open

# GRANTS

WINDOW DOOR OPTION MIX

## SLIDING WINDOW (2 PANELS ON 2 TRACKS)



- Handle option
- Select panel position from L/R
- Single slide (L/R) available
- Glazing finish
  - 8 - 13.52mm : Glazing channel
  - Other glass : Sealant

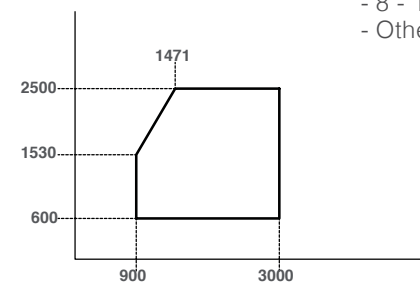

## AWNING WINDOW



- In case of IG, please consult with our technician for size and performance
- Pleated insect screen available
- Glazing finish
  - 8 - 13.52mm : Glazing channel
  - 28 - 31.52mm : Glazing channel
  - Other glass : Sealant

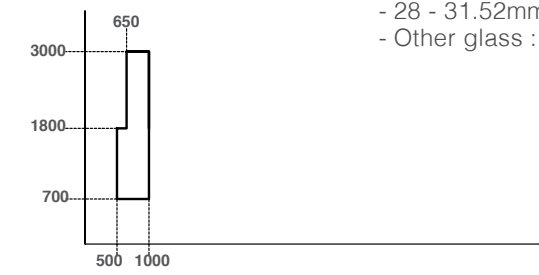

## CASEMENT WINDOW (WITH HINGE OR PIVOT)



- Select from L/R
- Pleated insect screen available
- Glazing finish
  - 8 - 13.52mm : Glazing channel
  - 28 - 31.52mm : Glazing channel
  - Other glass : Sealant

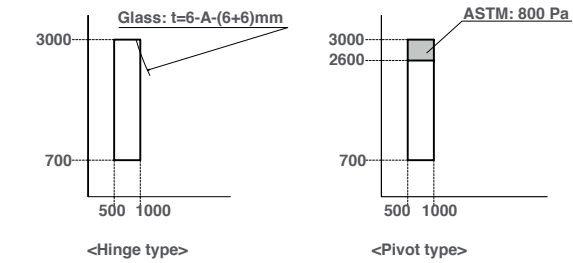

## SLIDING WINDOW (4 PANELS ON 2 TRACKS)



- Handle option
- Select from (SSSS, FSSF)
- Glazing finish
  - 8 - 13.52mm : Glazing channel
  - Other glass : Sealant

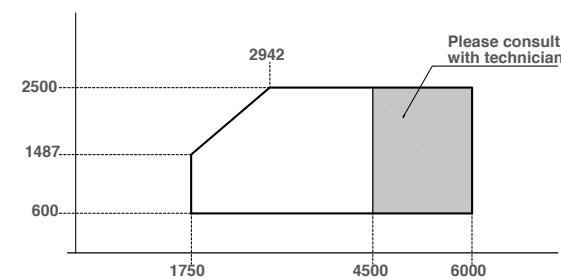

## SLIDING WINDOW (3 PANELS ON 2 TRACKS) SFS



- Handle option
- Glazing finish
  - 8 - 13.52mm : Glazing channel
  - Other glass : Sealant

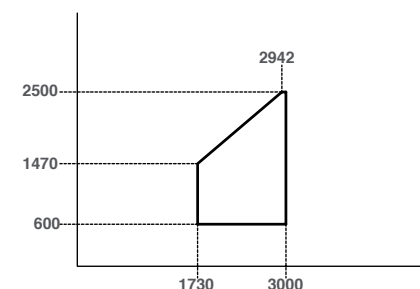

## CASEMENT WINDOW (WITH FRICTION STAY)



- In case of glass thickness over 8 mm and IG unit please consult with our technician
- Select from L/R
- Pleated insect screen available
- Glazing finish
  - 8 - 13.52mm : Glazing channel
  - 28 - 31.52mm : Glazing channel
  - Other glass : Sealant

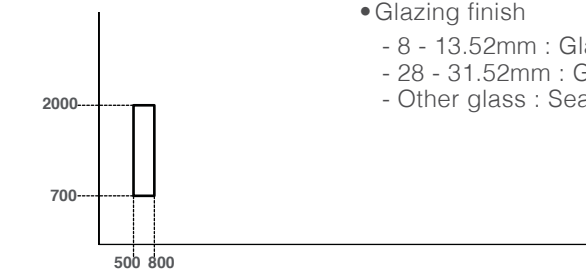

## MIXED & COMBINATION WINDOW

- Mullions are available for various windows and doors, Please consult with our sales representative for selection
- 180° mullion (standard and reinforced)
- 90° mullion (only for outward corner)

## FIXED WINDOW



- For oversize fixed windows, please consult with our technician
- Glazing finish
  - 8 - 13.52mm : Glazing bead
  - 25 - 31.52mm : Glazing bead
  - Other glass : Sealant

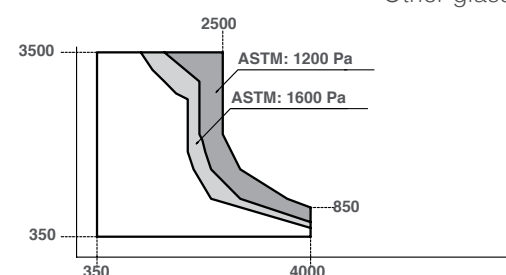

## CORNER FIXED WINDOW



- Only available in SG
- Only available with sealant finish
- Both in/outward corner available

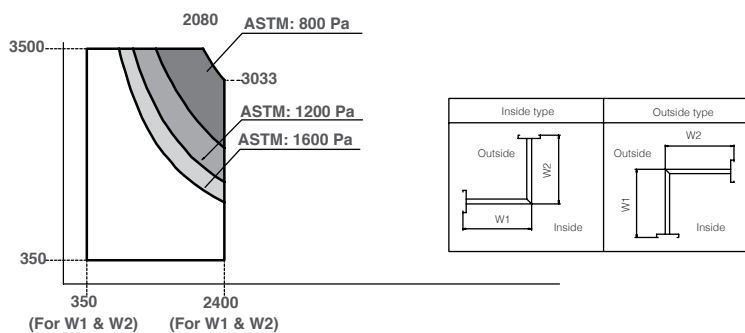

## SLIDING DOOR (2 PANELS ON 2 TRACKS)



- Handle option
- Select panel position from L/R
- Single slide (L/R) available
- Glazing finish
  - 8 - 13.52mm : Glazing channel
  - Other glass : Sealant

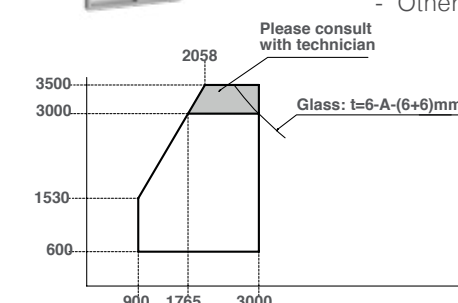

## SLIDING DOOR (4 PANELS ON 2 TRACKS)



- Handle option
- Select from (SSSS, FSSF)
- Glazing finish
  - 8 - 13.52mm : Glazing channel
  - Other glass : Sealant

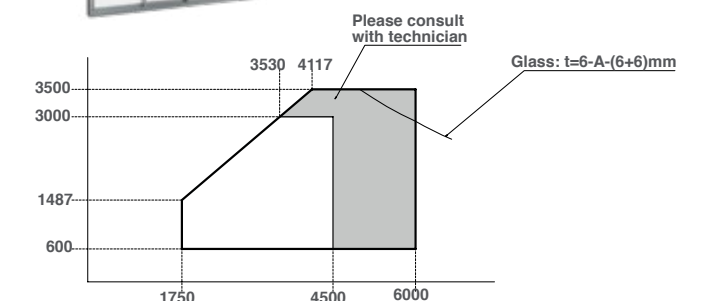

SLIDING DOOR (3 PANELS ON 2 TRACKS) SFS



- Handle option
- Glazing finish
  - 8 - 13.52mm : Glazing channel
  - Other glass : Sealant

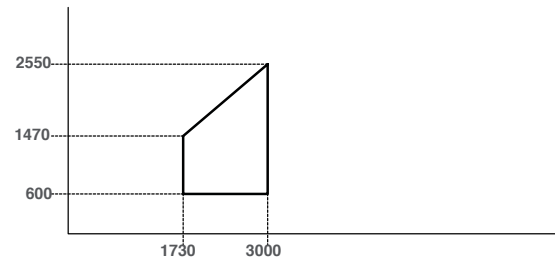

SLIDING DOOR (6 PANELS ON 3 TRACKS)



- Handle option
- Select from (SSSSSS, FSSSSF)
- Glazing finish
  - 8 - 13.52mm : Glazing channel
  - Other glass : Sealant

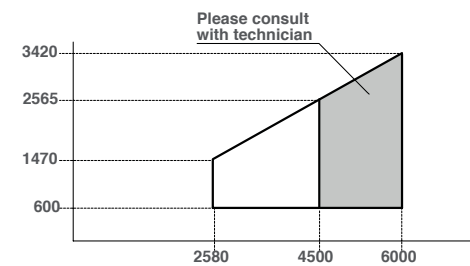

INSECT SCREEN



- This insect screen is for awning and casement window

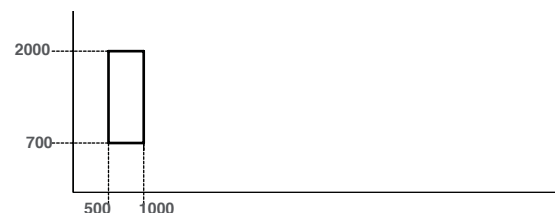

SLIDING DOOR (3 PANELS ON 3 TRACKS)



- Handle option
- Select panel position from L/R
- Select from (SSS, FSS, SSF)
- Glazing finish
  - 8 - 13.52mm : Glazing channel
  - Other glass : Sealant

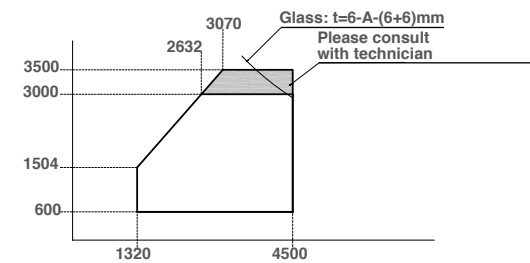

OUT-SWING DOOR (SINGLE)



- Pivot hinge option
- Door closer NOT available
- Select from L/R
- Glazing finish
  - 8 - 13.52mm : Glazing channel
  - 28 - 31.52mm : Glazing channel
  - Other glass : Sealant

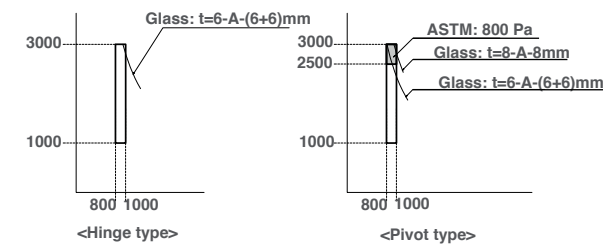

BOTTOM WINDOWS	TOP WINDOWS			
	Single Awning	Single Casement	Single Fix	Sliding
Single Awning			•	
Single Casement			•	
Swing Door			•	
Single Fix	•	•	•	•
Double Fix				•

FLAT RAIL SLIDING DOOR (2 PANELS ON 2 TRACKS)



- Handle option
- Select panel position from L/R
- Single slide (L/R) available
- Glazing finish
  - 8 - 13.52mm : Glazing channel
  - Other glass : Sealant

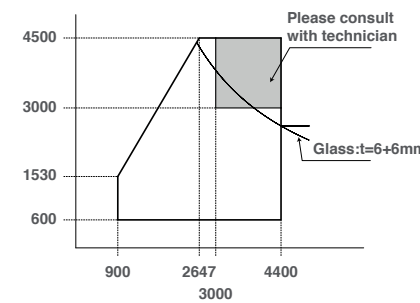

FLAT RAIL SLIDING DOOR (3 PANELS ON 3 TRACKS)



- Handle option
- Select panel position from L/R
- Select from (SSS, FSS, SSF)
- Glazing finish
  - 8 - 13.52mm : Glazing channel
  - Other glass : Sealant

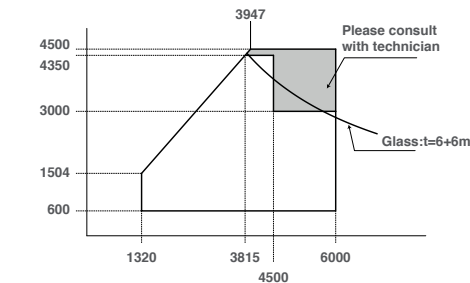

CORNER SLIDING DOOR (2+2 PANELS ON 2 TRACKS)



- Outer corner only
- Select from (SS+SS, FS+SF)
- Glazing finish
  - 8 - 13.52mm : Glazing channel
  - Other glass : Sealant

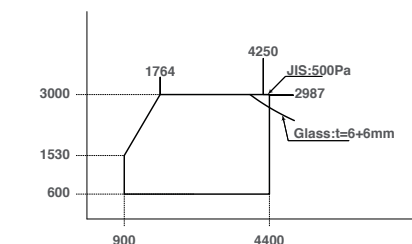

FLAT RAIL SLIDING DOOR (4 PANELS ON 2 TRACKS)



- Handle option
- Select from (SSSS, FSSF)
- Glazing finish
  - 8 - 13.52mm : Glazing channel
  - Other glass : Sealant

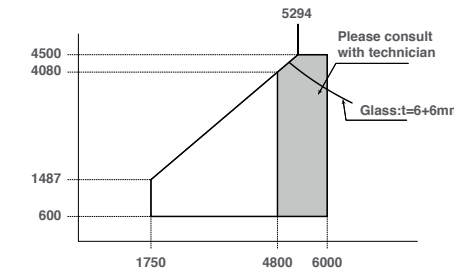

FLAT RAIL SLIDING DOOR (6 PANELS ON 3 TRACKS)



- Handle option
- Select from (SSSSSS, FSSSSF)
- Glazing finish
  - 8 - 13.52mm : Glazing channel
  - Other glass : Sealant

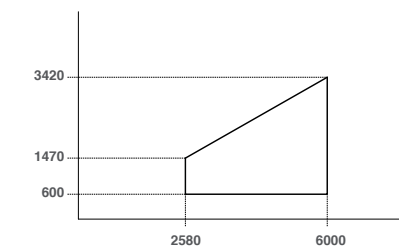

CORNER SLIDING DOOR (3+3 PANELS ON 3 TRACKS)



- Outer corner only
- Select from (SSS+SSS, FSS+SSF)
- Glazing finish
  - 8 - 13.52mm : Glazing channel
  - Other glass : Sealant

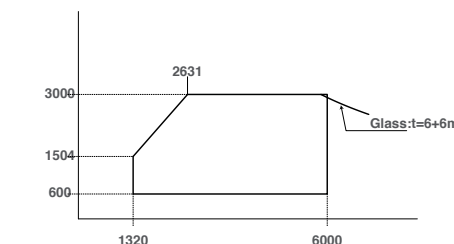



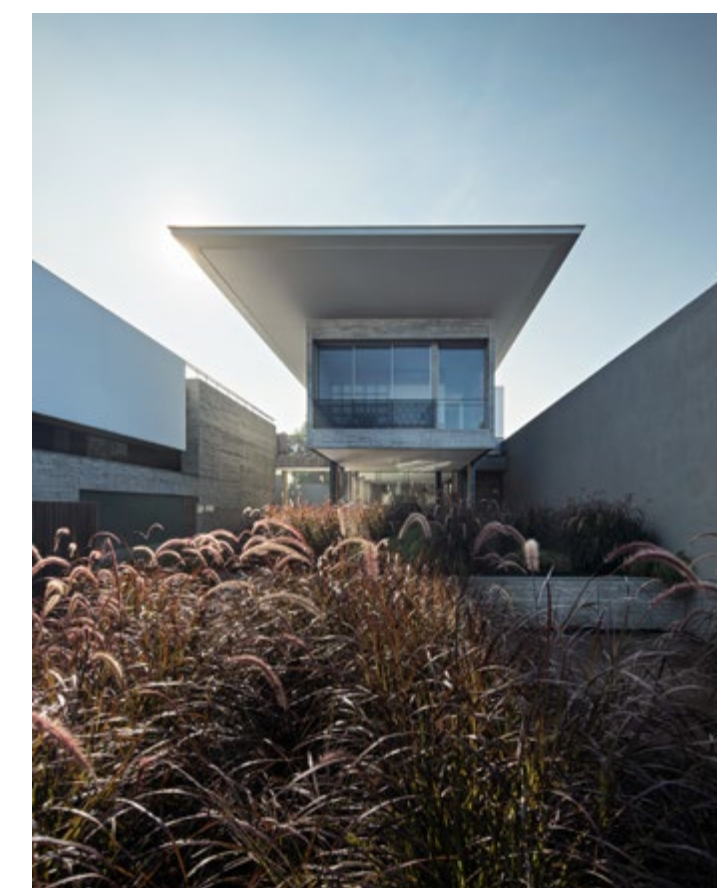
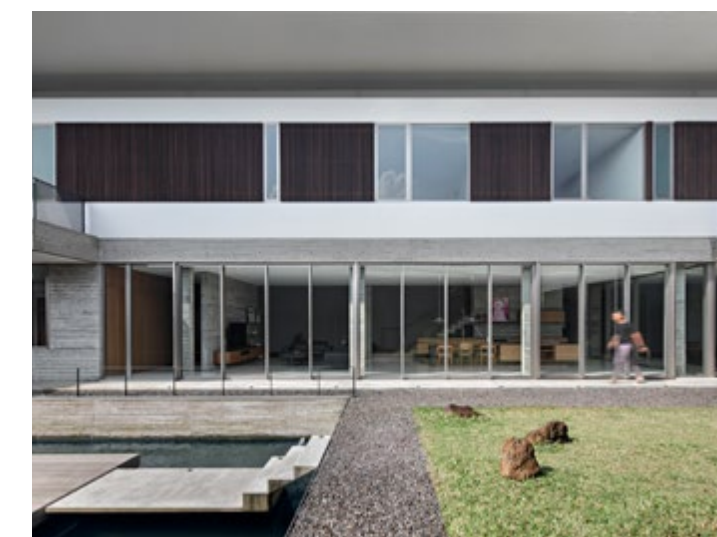

**GRANTS PROJECT  
REFERENCE**

PRIVATE HOUSE, INDONESIA









## ATIS series

|

**IT IS NOT A WINDOW-FRAME; IT IS  
MOVING ART.**

Our end goal is not just window frames.  
It is beauty. Because we believe nothing is more  
beautiful than life. We invite you to enjoy.

# ATIS PLUS

ATIS PLUS offers beautiful windows and doors for your high-rise projects, which has passed rigorous tests based on ASTM and TOSTEM in-house toughness standard.



## SPECIFICATIONS

FRAME DEPTH	88 MM 131.5 MM (3 TRACKS SLIDING)
HEIGHT OF SILL	55 MM
GLASS THICKNESS	5,6,8 - 15,52, 22 MM (24, 26 MM FOR FIXED WINDOW)

## COLOR



NATURAL WHITE



NATURAL SILVER



SHINE GRAY



AUTUMN BROWN



DUSK GRAY



NATURAL BLACK

## PERFORMANCES

WIND PRESSURE



2000 PA  
(ASTM E330)

WATER TIGHTNESS



300 PA  
(ASTM E331)

AIR TIGHTNESS



10.7M<sup>3</sup>/H·M<sup>2</sup>  
(ASTM E283)

NOISE INSULATION



T-1 (25),  
T-2 (30)<sup>2</sup>  
(JIS A 1416)

<sup>1</sup>\* Sound performance test has been done in JIS standard controlled environment. Performance will vary by room condition. Please consult with sound insulation specialist.

<sup>2</sup>\* Some specific window types and glasses



# ATIS

ATIS is not only esthetically pleasing but has an enormous amount of innovation and technology "build within". All ATIS products follow the same simple design concept: Seamlessly unites the inside of your home with the outside without taking anything away.

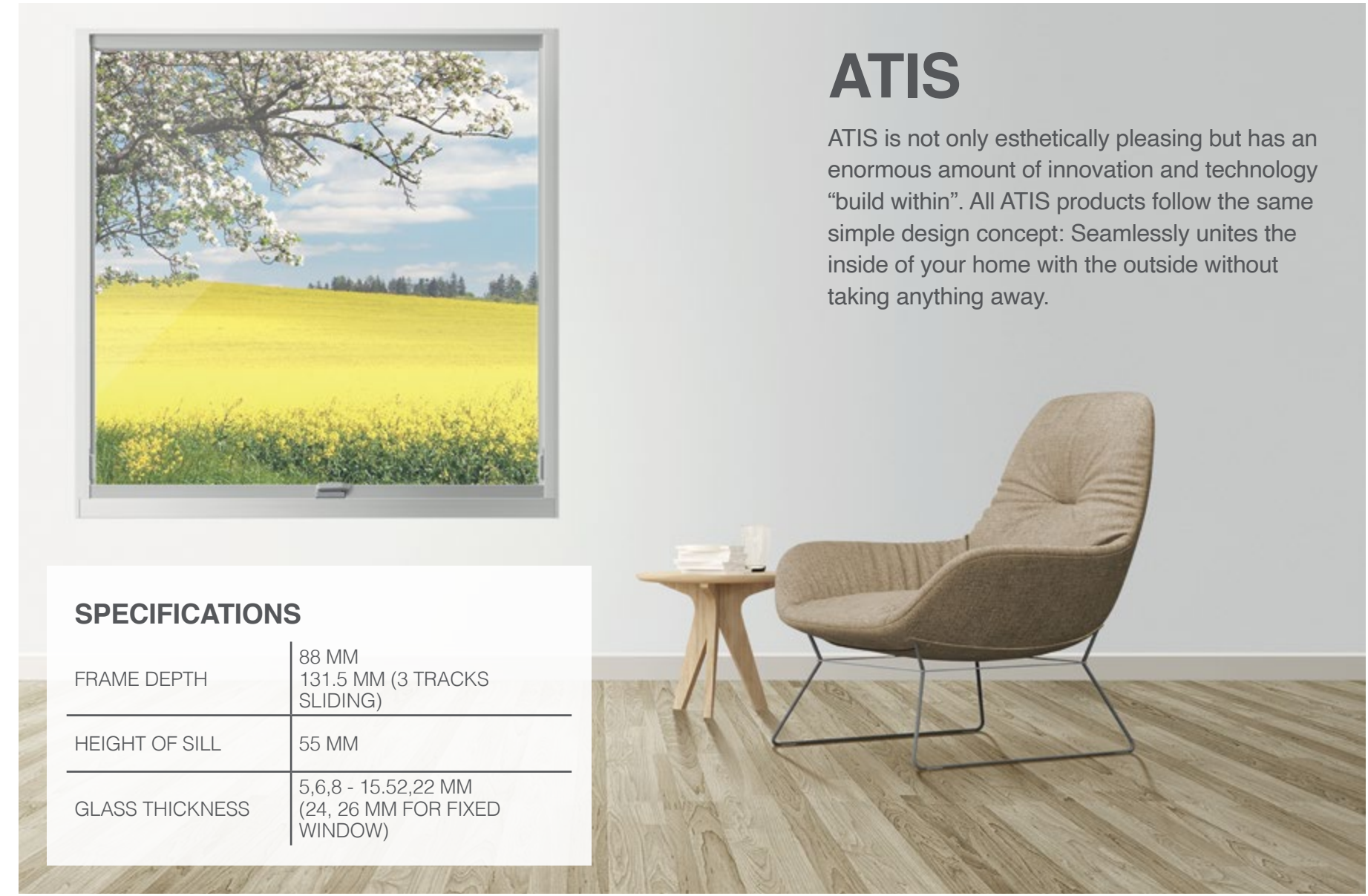

## SPECIFICATIONS

FRAME DEPTH	88 MM 131.5 MM (3 TRACKS SLIDING)
HEIGHT OF SILL	55 MM
GLASS THICKNESS	5,6,8 - 15,52,22 MM (24, 26 MM FOR FIXED WINDOW)

## COLOR



NATURAL WHITE



NATURAL SILVER

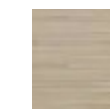

SHINE GRAY



AUTUMN BROWN



DUSK GRAY



NATURAL BLACK

## PERFORMANCES

WIND PRESSURE



S-2 (1200 PA)  
(JIS A 1515)

WATER TIGHTNESS



W-3 (250 PA)  
(JIS A 1517)

AIR TIGHTNESS



A-4 (2)  
(JIS A 1516)

NOISE INSULATION



T-1 (25),  
T-2 (30)<sup>2</sup>  
(JIS A 1416)

<sup>1</sup>\* Sound performance test has been done in JIS standard controlled environment. Performance will vary by room condition. Please consult with sound insulation specialist.

<sup>2</sup>\* Some specific window types and glasses





## UNIQUE FEATURES

### STREAMLINED DESIGN

Seamless design with beautiful functionality. Smooth lines, surfaces, and operation. Works as beautifully as it looks.

### CONCEALED HARDWARE



SUB-LOCK



HINGES



BALANCER

\* Only available for ATIS series

### SLIM MULLION



40 MM MULLION

### L-FIT DESIGN HANDLES



OPERATOR HANDLE

\* Only available for ATIS series



CAM-LATCH HANDLE



LEVER HANDLE



CRESCENT LOCK

### SMART INSECT SCREEN



\* Only available for ATIS series

### INVISIBLE SCREEN

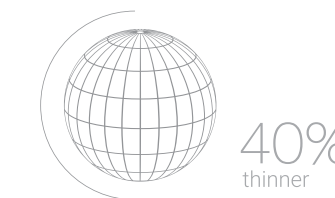

We use a 40% thinner wire than conventional insect screens. So you get a 20% clearer view.



We have shrunk the space for bugs to squeeze through by 20%, so not even the tiniest gnat can get in.

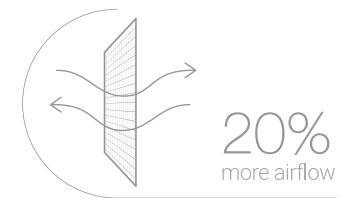

With more AIRFLOW than conventional insect screens, INVISIBLE SHIELD lets more insect-free AIRFLOW through than any others.

# Awning / Casement Window



L-FIT HANDLE

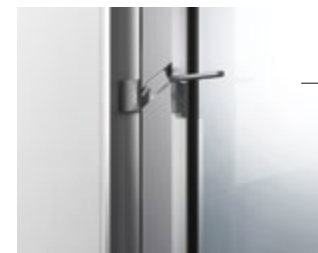

LIMIT ARM FOR SAFETY (OPTION)



CASEMENT WINDOW (WITH CAM-LATCH HANDLE)



CASEMENT WINDOW (WITH OPERATOR HANDLE)



SMART INSECT SCREEN SYSTEM



L-FIT DESIGN HANDLE

## SLIT WINDOW WITH CHAIN OPERATOR



Specially designed for rooms where you want to keep outside eyes out but let the breeze in.

You can open our slit windows without having to reach up to window height. We help you make the most out of every living area in your home.



# Tilt & Slide Window

LOCK DEVICE



SAFETY STOPPER

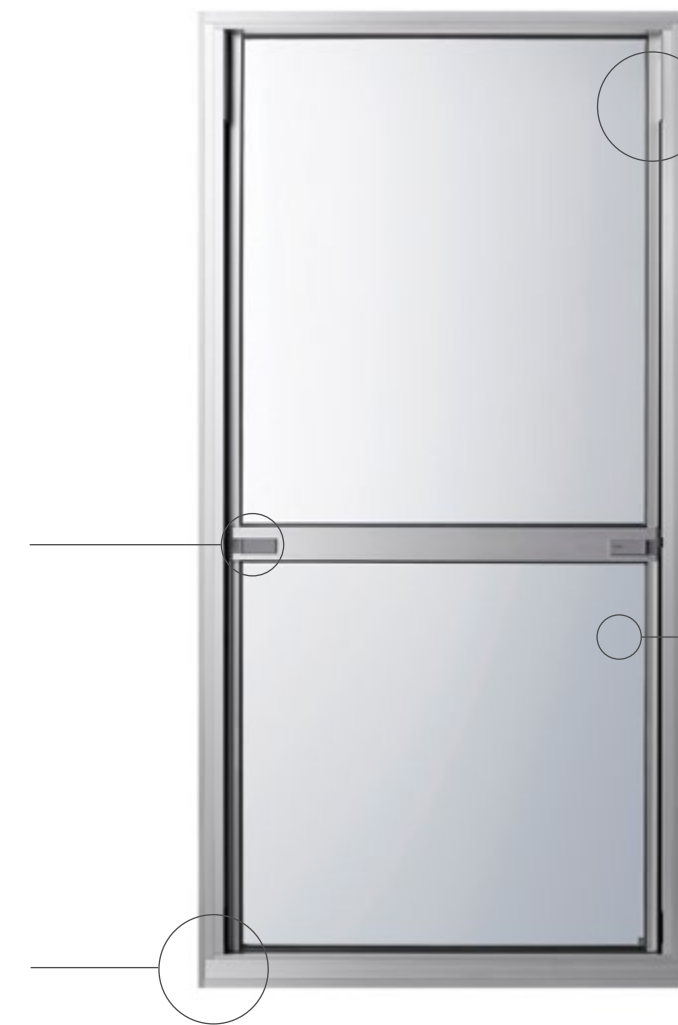

CONCEALED POWER SUPPORT SYSTEM



SLIDING INSECT SCREEN (OUTSIDE)



CLOSED POSITION



TILTED POSITION



OPENED POSITION





# Sliding Window / Door



ALUMINUM PROFILE HANDLE

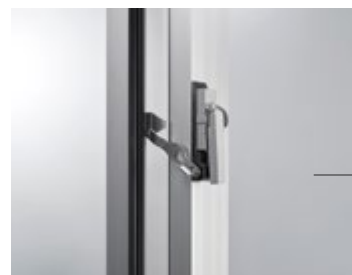

LIMIT ARM (OPTION)

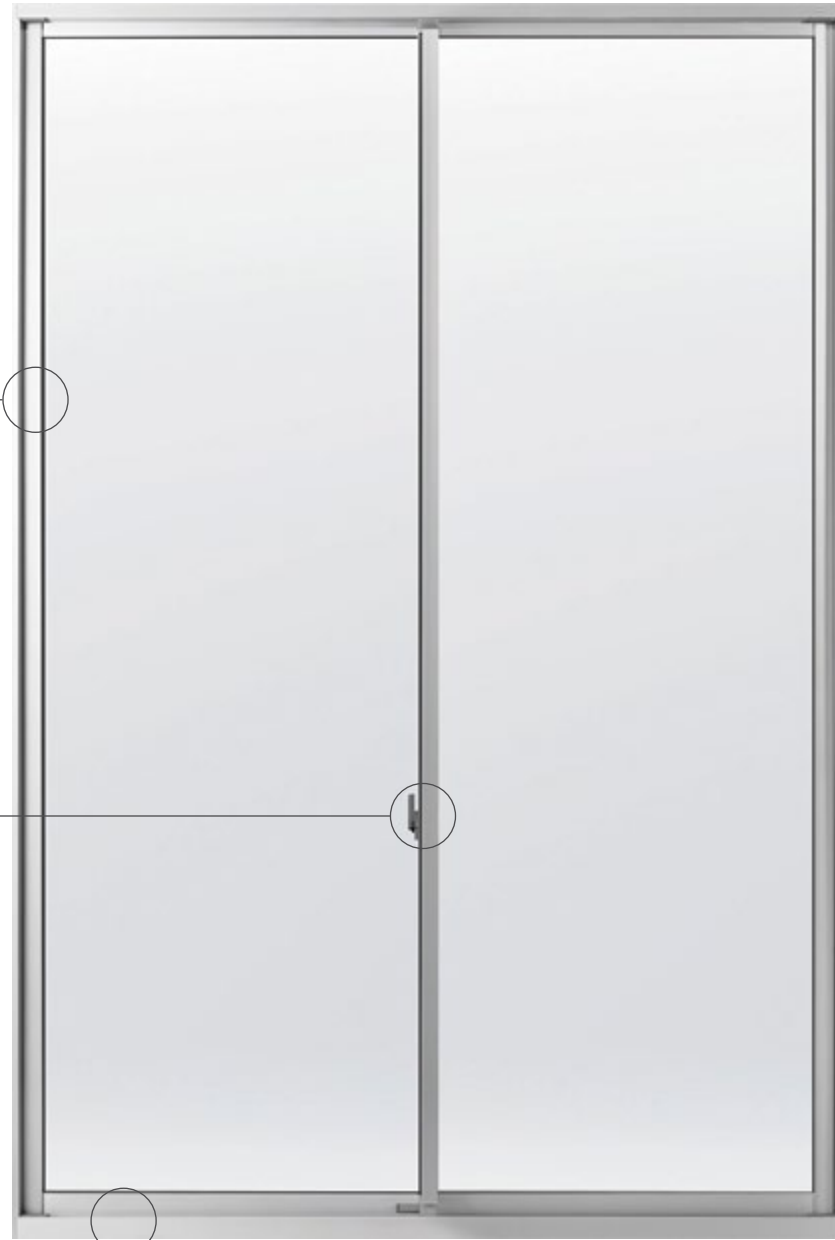

## FLAT ATTACHMENT (OPTION)



SAFE FOR EVERYONE



DETACHABLE

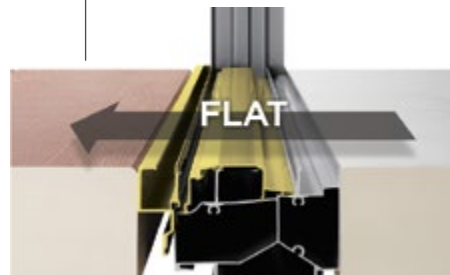

FOR OUTER RAIL (OUTER PANEL FIXED)

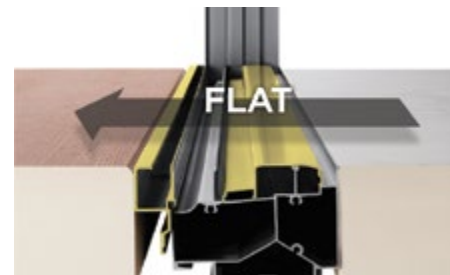

FOR INNER RAIL (INNER PANEL FIXED)

# Swing Door



CONCEALED FRICTION ARM



CONCEALED HINGES

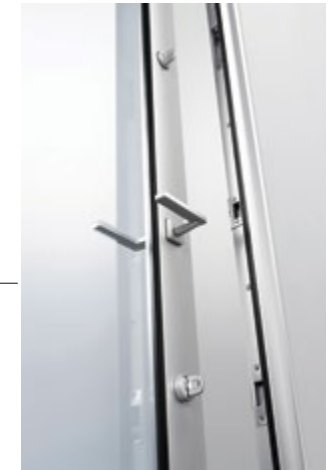
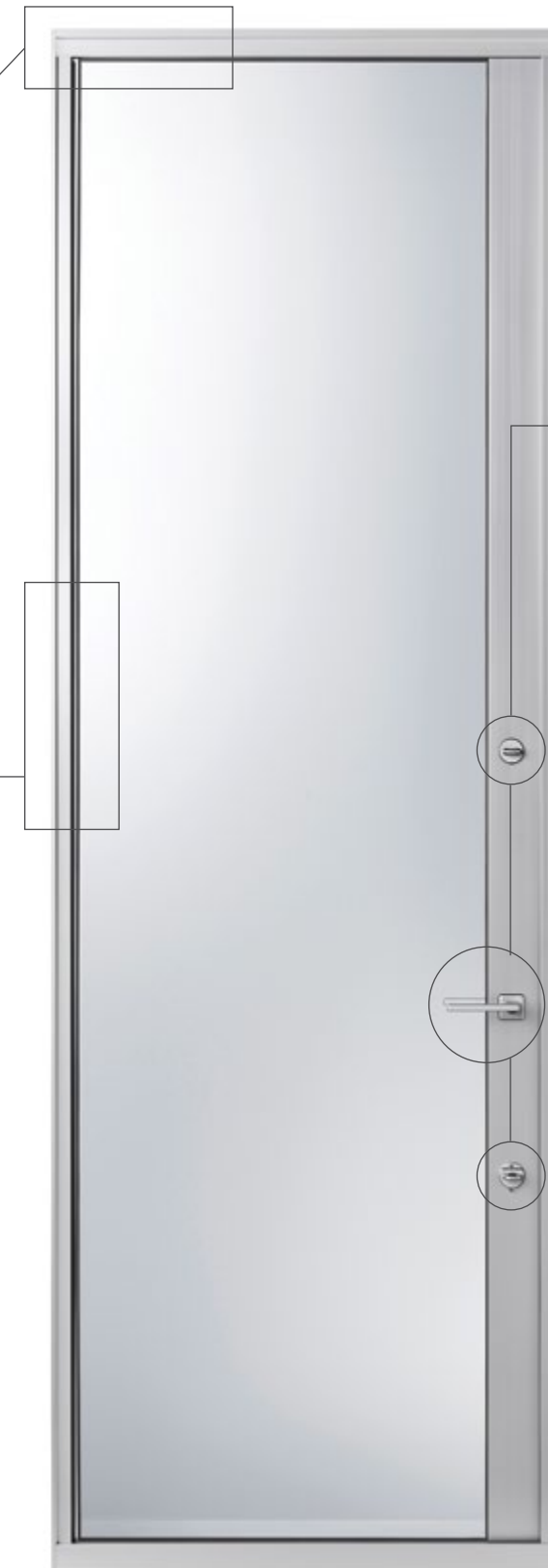

L-FIT DESIGN HANDLE AND LOCK SET

<CONVENTIONAL>



<ATIS>



DOUBLE SWING DOOR WITH MAXIMIZED GLASS AREA (RECOMMENDED FOR LOW-RISE PROJECTS)

# ATIS PLUS

- WINDOW
- DOOR
- OPTION
- MIX

Glazing Channel & Bead availability

Channel : Sliding, Casement, Awning, Swing door, Tilt & Slide

Bead : FIX

Type	5	6	8	8.38	8.76	9.52	10	10.38
Channel	○	○	○	○	○	○	○	○
Bead	○	○	○	-	-	-	○	○
Type	10.76	11.52	12	13.52	15.52	22	24	26
Channel	○	○	○	○	○	○	-	-
Bead	○	○	○	○	○	○	○	○

## SLIDING WINDOW (4 PANELS ON 2 TRACKS)



- External insect screen available
- Internal insect screen (optional)

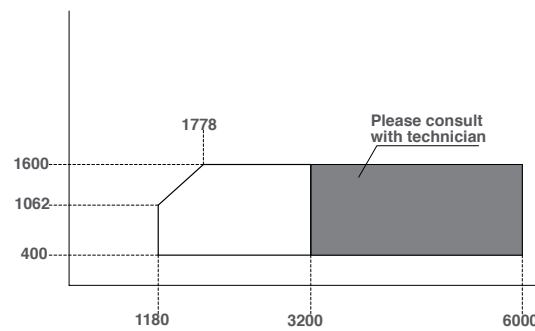

## CASEMENT WINDOW (WITH SUBLOCK)



- In case of over 8mm glass thickness, please consult with our technician
- Select from L/R
- Swing screen available
- Safety arm option

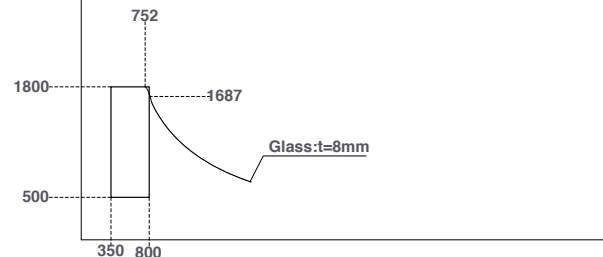

## SLIDING WINDOW (2 PANELS ON 2 TRACKS)



- External insect screen available
- Internal insect screen (optional)
- Safety arm option

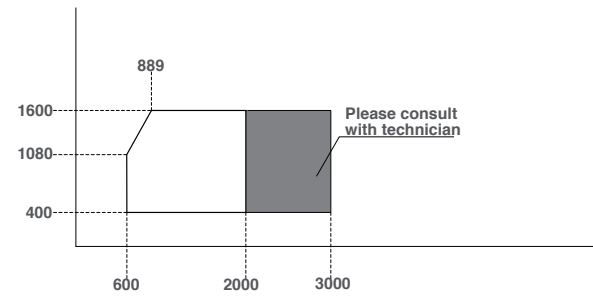

## AWNING WINDOW (WITH SUBLOCK)



- In case of over 8mm glass thickness, please consult with our technician
- Swing screen available

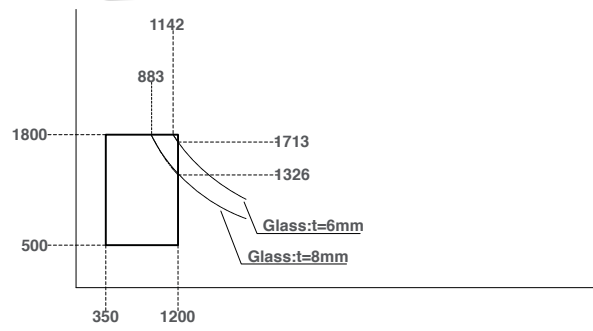

## FIXED WINDOW



- Wind load performance varies by glass thickness, please consult with our technician

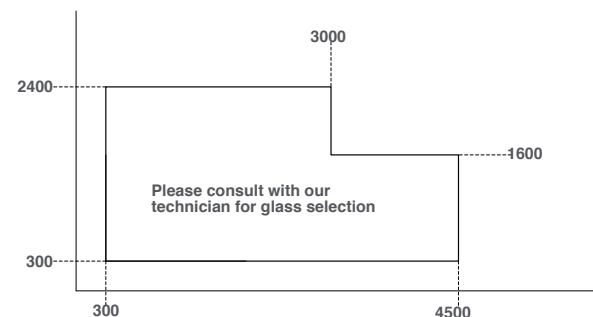

## CORNER FIXED WINDOW



- Only available in SG
- Only available with sealant finish
- Both in/outward corner available
- Middle bar (optional)

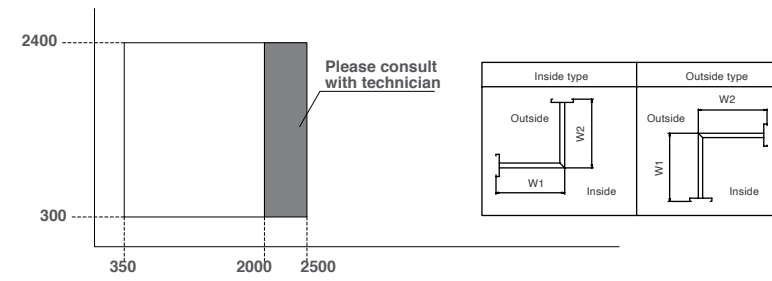

## SLIDING DOOR (2 PANELS ON 2 TRACKS)



- External insect screen available
- Internal insect screen (optional)
- Safety arm option
- Flat attachment option

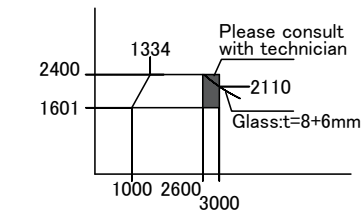

## OUT-SWING DOOR (SINGLE)



- Door closer not available
- Select from L/R

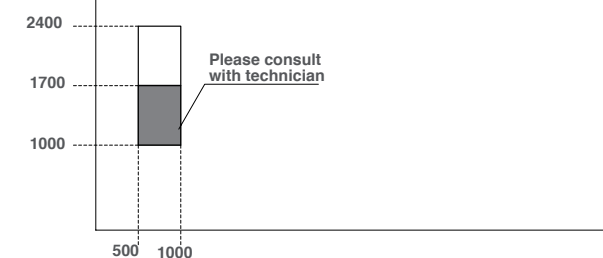

## FIX UNIT VARIATION



- Wind load performance varies by glass thickness, Please consult with our technician

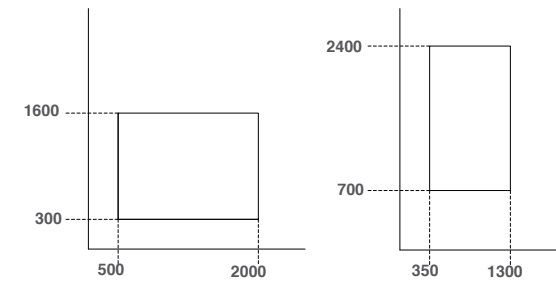

## SLIDING DOOR (4 PANELS ON 2 TRACKS)



- External insect screen available
- Internal insect screen (optional)
- Flat attachment option

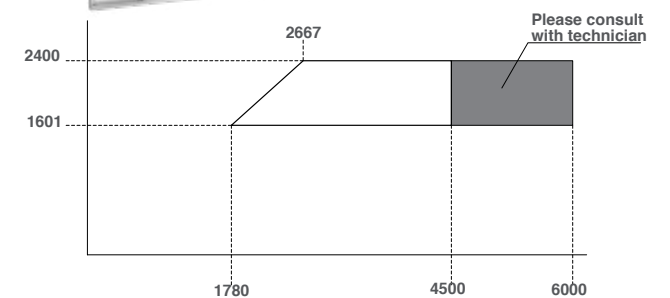

## MIXED & COMBINATION WINDOW

- Mullions and Transoms are available for various windows and doors, Please consult with our sales representative for selection 180° mullion (standard and reinforced)



# ATIS

- WINDOW
- DOOR
- OPTION
- MIX

Glazing Channel & Bead availability

Channel : Sliding, Casement, Awning, Swing door, Tilt & Slide

Bead : FIX

Type	5	6	8	8.38	8.76	9.52	10	10.38
Channel	○	○	○	○	○	○	○	○
Bead	○	○	○	-	-	-	○	○
Type	10.76	11.52	12	13.52	15.52	22	24	26
Channel	○	○	○	○	○	○	-	-
Bead	○	○	○	○	○	○	○	○

## SLIDING WINDOW (4 PANELS ON 2 TRACKS)



- External insect screen available
- Internal insect screen (optional)

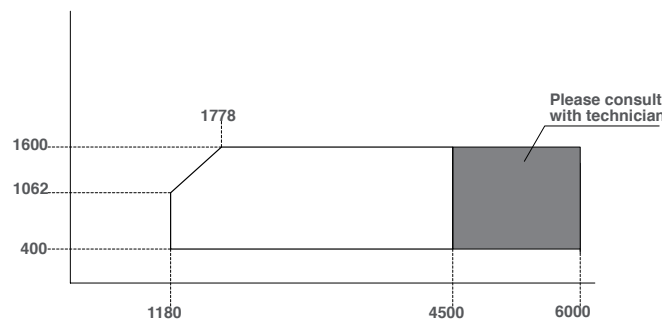

## AWNING OPERATOR WINDOW



- In case of over 8mm glass thickness, please consult with our technician
- Smart screen available

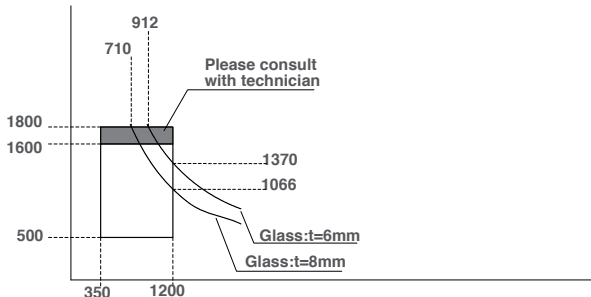

## SLIDING WINDOW (2 PANELS ON 2 TRACKS)



- In case of over 8mm glass thickness, please consult with our technician
- External insect screen available
- Internal insect screen (optional)
- Safety arm option

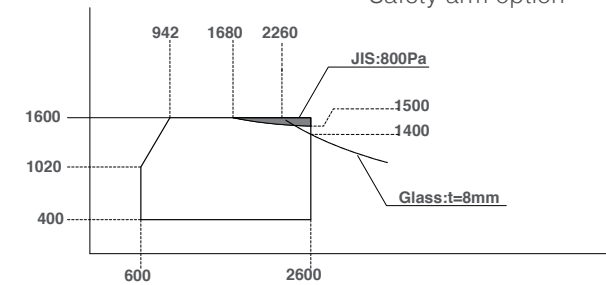

## AWNING WINDOW (SINGLE LOCK)



- In case of over 8mm glass thickness, please consult with our technician
- Swing screen available

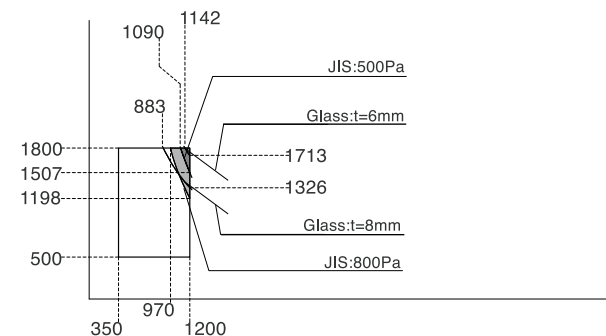

## AWNING SLIT WINDOW



- In case of over 8mm glass thickness, please consult with our technician
- Smart screen available
- Select from Pully chain or orbit handle

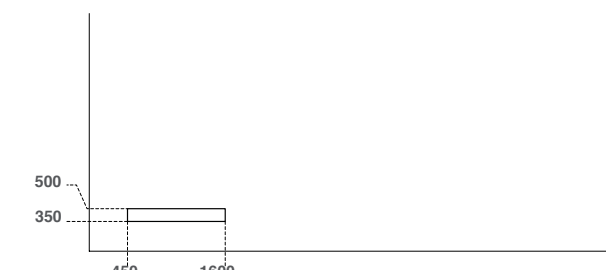

## CASEMENT WINDOW (SINGLE LOCK)



- In case of over 8mm glass thickness, please consult with our technician
- Select from L/R
- Swing screen available
- Safety arm option

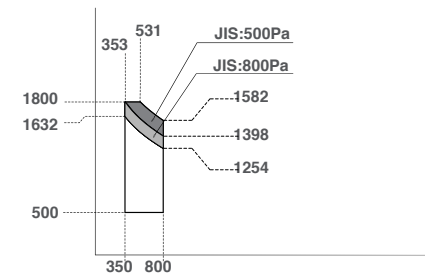

## FIXED WINDOW



- Wind load performance varies by glass thickness, please consult with our technician

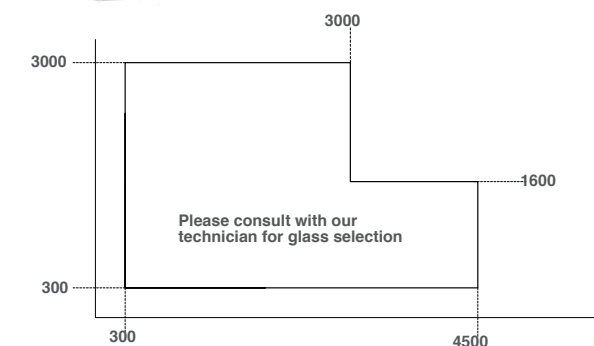

## FIX UNIT VARIATION

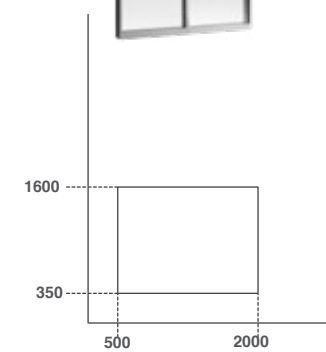

## DOUBLE CASEMENT WINDOW



- In case of over 15mm glass thickness, please consult with our technician
- Swing screen available

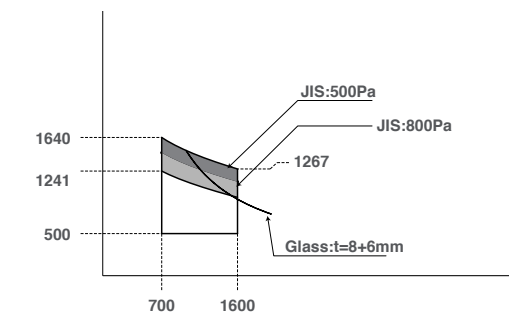

## CASEMENT OPERATOR WINDOW



- In case of over 8mm glass thickness, please consult with our technician
- Select from L/R
- Smart screen available
- Safety arm option

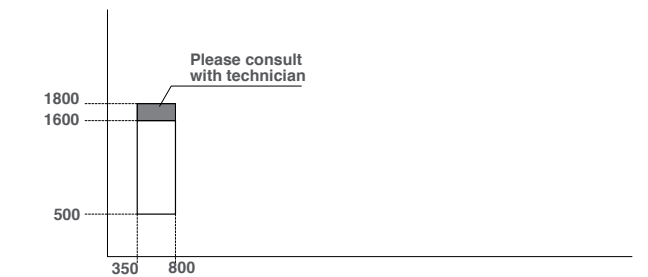

## CORNER FIXED WINDOW



- Only available in SG
- Only available with sealant finish
- Both in/outward corner available
- Middle bar (optional)

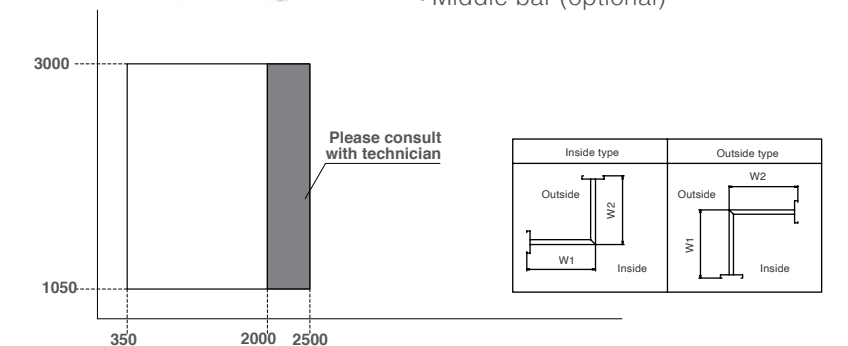

**TILT & SLIDE**



- In case of over 8mm glass thickness, please consult with our technician
- External insect screen available

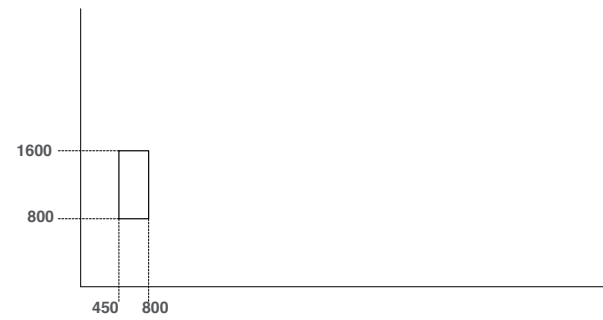

**SLIDING DOOR (4 PANELS ON 2 TRACKS)**



- In case of over 10mm glass thickness, please consult with our technician
- External insect screen available
- Internal insect screen (optional)
- Flat attachment option

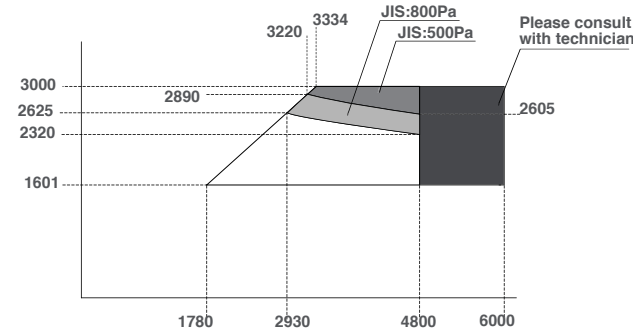

**SLIDING DOOR (6 PANELS ON 3 TRACKS)**



- External insect screen available

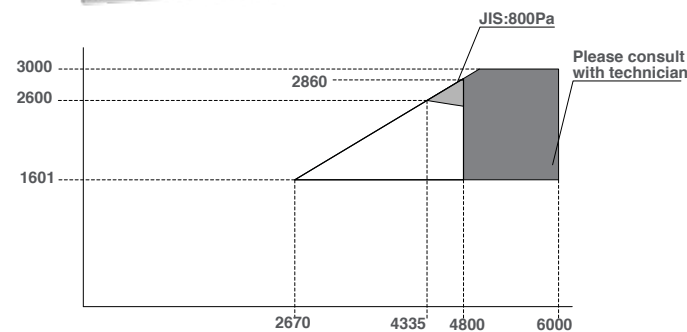

**SLIDING DOOR (2 PANELS ON 2 TRACKS)**



- In case of over 11 mm glass thickness, please consult with our technician
- External insect screen available
- Internal insect screen (optional)
- Safety arm option
- Flat attachment option

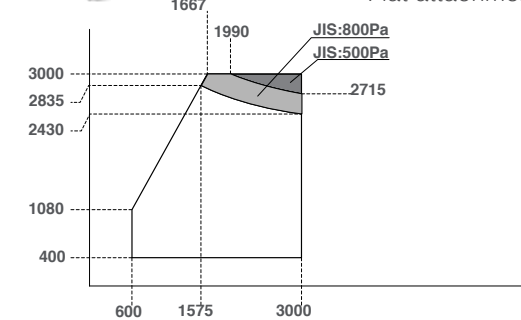

**SLIDING DOOR (3 PANELS ON 3 TRACKS)**



- In case of over 11 mm glass thickness, please consult with our technician
- External insect screen available

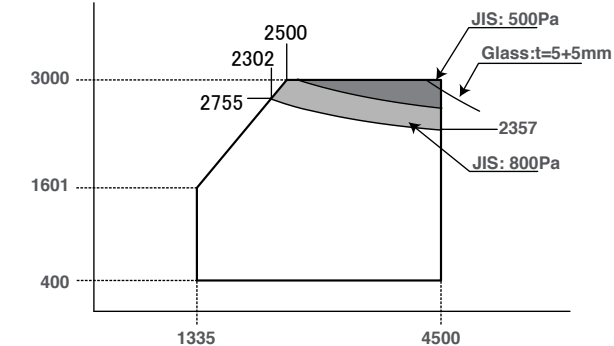

**OUT-SWING DOOR (SINGLE)**



- In case of over 15 mm glass thickness, please consult with our technician
- Door closer Not available
- Select from L/R

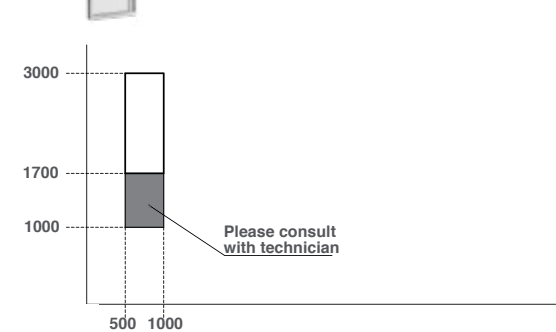

**OUT-SWING DOOR (DOUBLE)**



- In case of over 13 mm glass thickness, please consult with our technician
- Door closer Not available
- Select from L/R

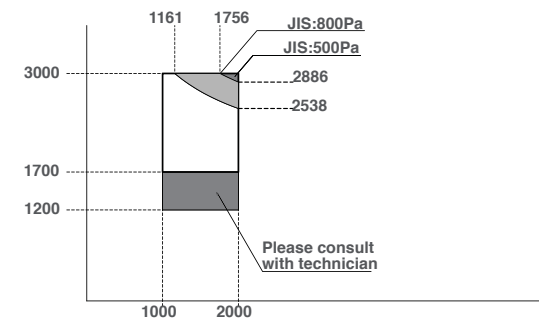

**ENTRANCE SLIDING DOOR (4 PANELS)**



- In case of over 15mm glass thickness, please consult with our technician
- External insect screen available
- Flat attachment option

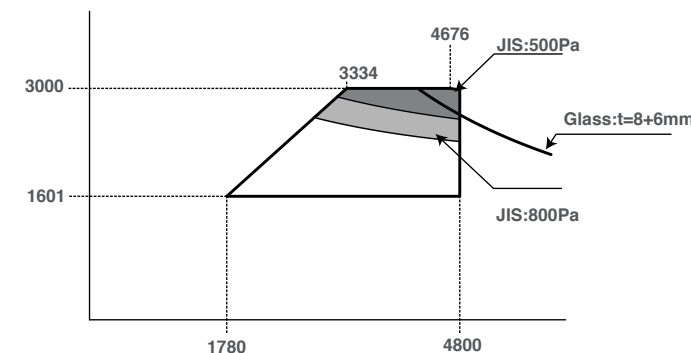

**ENTRANCE SLIDING DOOR (2 PANELS)**



- External insect screen available
- Flat attachment option

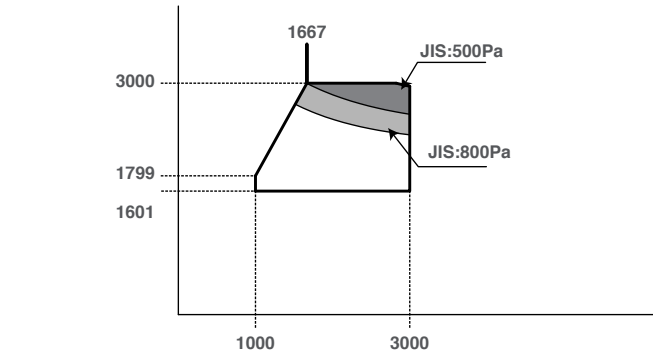

**MIXED & COMBINATION WINDOW**

- Mullions and Transoms are available for various windows and doors, Please consult with our sales representative for selection
- 180° mullion (standard and reinforced)
- 90° mullion (only for outward corner)





**ATIS PROJECT  
REFERENCE**

PRIVATE HOUSE, THAILAND



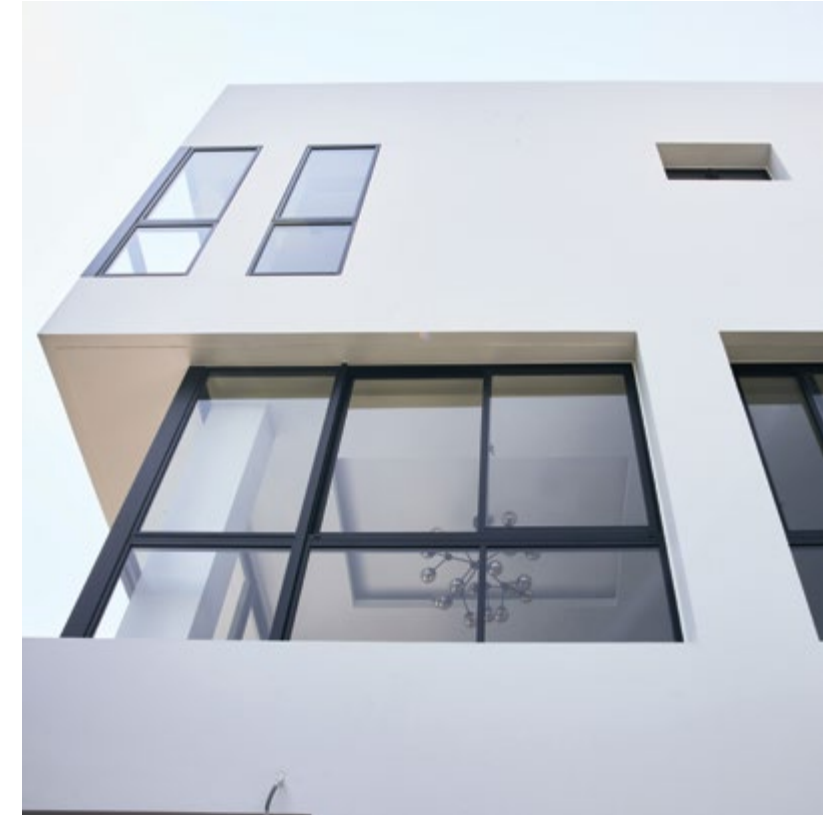





## WE series

|

Discover Japan's quality and craftsmanship with TOSTEM WE series. Our high-performing products elevate everyday living with superior functionality.

# WE series

## COLOR



NATURAL WHITE



AUTUMN BROWN



NATURAL SILVER



DUSK GRAY



SHINE GRAY



NATURAL BLACK

## WE PLUS

WE PLUS has passed rigorous tests based on ASTM, and TOSTEM in-house's toughest standards. Available in various designs with a maximum height of 3 meters to satisfy various designers' needs in high-rise market.



### SPECIFICATIONS

FRAME DEPTH	72 MM 104 MM (3 TRACKS SLIDING)
HEIGHT OF SILL	35 MM 50 MM (ALL SLIDINGS)
GLASS THICKNESS	5, 6, 8 MM

### PERFORMANCES

WIND PRESSURE	WATER TIGHTNESS	AIR TIGHTNESS	NOISE INSULATION
1600Pa (ASTM E330)	240Pa (ASTM E300)	10.7M <sup>3</sup> /H·M <sup>2</sup> (ASTM E283)	T-1: 25DB (JIS)

\* Sound performance test has been done in JIS standard controlled environment. Performance will vary by room condition. Please consult with sound insulation specialist.

## WE 70

WE 70 series brings legendary TOSTEM quality to everyday life. Built for the mass market, yet maintaining strict quality standards. The WE 70 series is priced within everyone's reach.



### SPECIFICATIONS

FRAME DEPTH	72 MM 104 MM (3 TRACKS SLIDING)
HEIGHT OF SILL	35 MM
GLASS THICKNESS	5, 6, 8 MM

### PERFORMANCES

WIND PRESSURE	WATER TIGHTNESS	AIR TIGHTNESS	NOISE INSULATION
S-1 (800PA) (JIS A 1515)	W-2 (150PA) (JIS A 1517)	A-3 (10) (JIS A 1516)	T-1 (25) (JIS A 1416)

\* Sound performance test has been done in JIS standard controlled environment. Performance will vary by room condition. Please consult with sound insulation specialist.

## WE 40

WE 40 series, windows bring legendary TOSTEM quality to everyday life. Built for the mass market, they maintain strict quality standards.



### SPECIFICATIONS

FRAME DEPTH	41 MM
HEIGHT OF SILL	35 MM
GLASS THICKNESS	5, 6 MM

### PERFORMANCES

WIND PRESSURE	WATER TIGHTNESS	AIR TIGHTNESS	NOISE INSULATION
(500PA) (JIS A 1515)	W-1 (100PA) (JIS A 1517)	A-3 (10) (JIS A 1516)	N/A (JIS A 1416)

\* Sound performance test has been done in JIS standard controlled environment. Performance will vary by room condition. Please consult with sound insulation specialist.



UNIQUE FEATURES

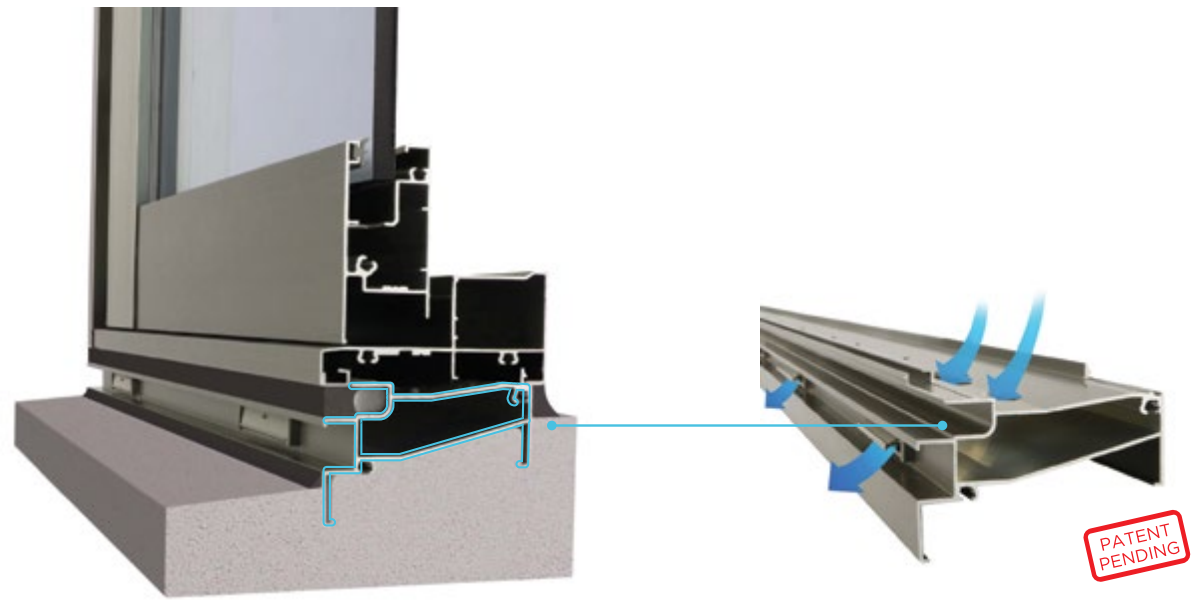

**PRE-INSTALLED SILL ATTACHMENT FOR PRE-CAST CONCRETE (OPTION)**

Attachment allows stability around windows for a longer time against the aged deterioration of a sealant. In case of water entry from outside sealant, attachment prevents water from penetrating inside.

\* Only available for WE PLUS

AIRFLOW SLOT



Smooth operation with bearing rollers



Air tightness: JIS A-3 when closed



Detachable insect screen for cleaning

\* Available with all windows



watertight sill with drainage devices

UNIQUE FEATURES



Watertight sill with drainage system



Flat sill is available and allows barrier-free passage



Smart designs prevent finger injuries



Hinge-less design

PRODUCT VARIETY (INSIDE VIEW)

PANELS	ONE WAY	BOTH WAYS	CENTER
4 PANELS			
6 PANELS			
8 PANELS			
12 PANELS			
16 PANELS			

# WE PLUS

WINDOW

DOOR

OPTION

MIX

## SLIDING WINDOW (2 PANELS ON 2 TRACKS)



- Inside insect screen available

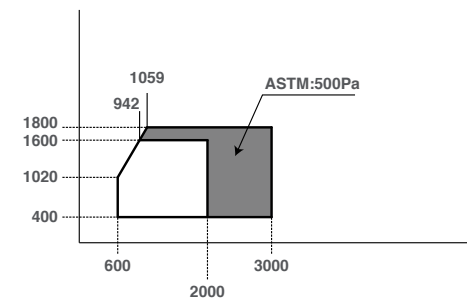

## SLIDING WINDOW (3 PANELS ON 3 TRACKS)



- Inside insect screen available

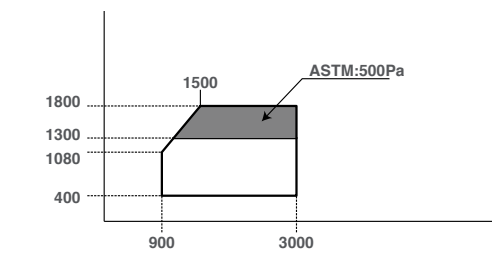

## SLIDING WINDOW (4 PANELS ON 2 TRACKS)



- Inside insect screen available

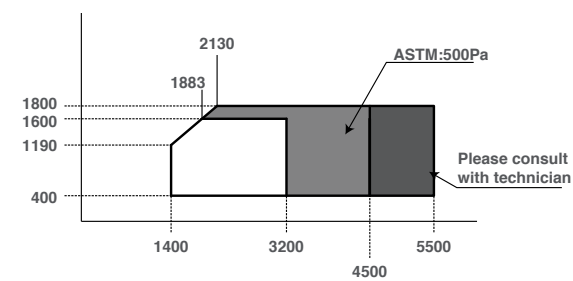

## AWNING WINDOW (SINGLE LOCK)



- Insect screen available

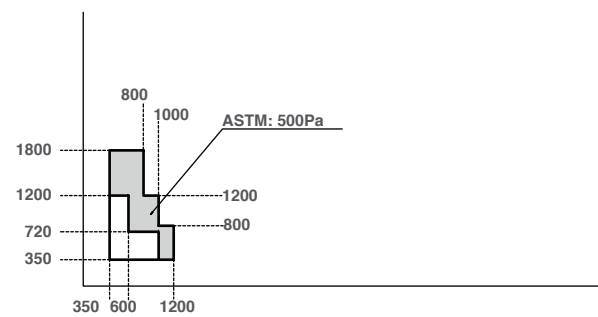

## AWNING WINDOW (MULTI LOCK)



- Insect screen NOT available

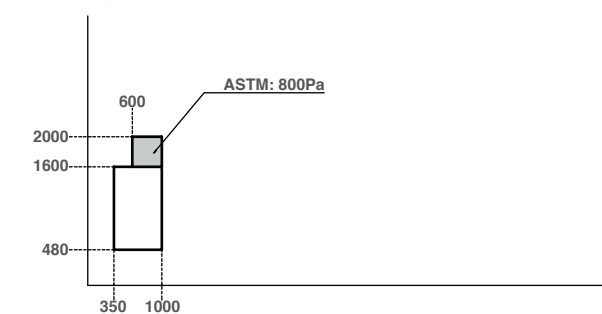

## CASEMENT WINDOW (SINGLE LOCK)



- Insect screen available
- Select from L/R
- Safety arm (Optional)

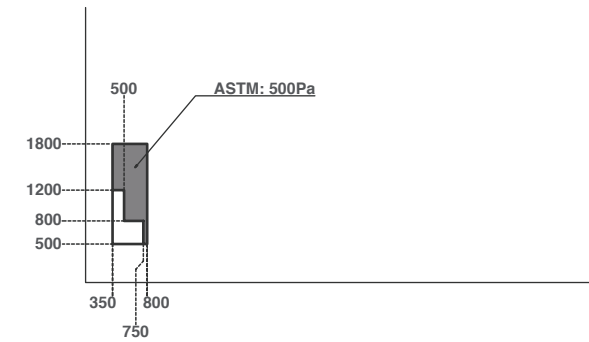

## FIXED WINDOW



- Wind load performance varies by glass thickness, please consult with our technician

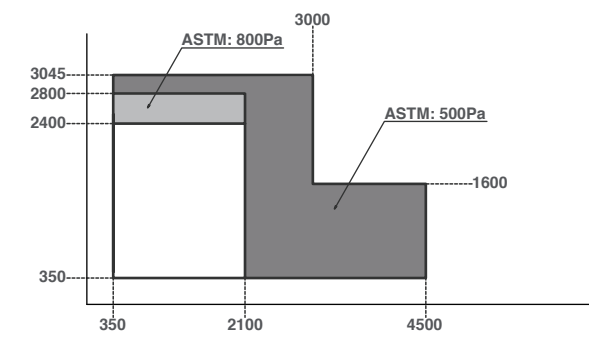

## CASEMENT WINDOW (MULTI LOCK)



- Insect screen NOT available
- Select from L/R
- Safety arm (Optional)

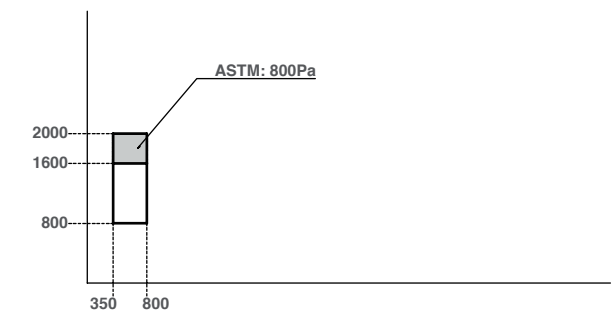

## CORNER FIXED WINDOW



- Available only in outward corner
- Middle bar (optional)

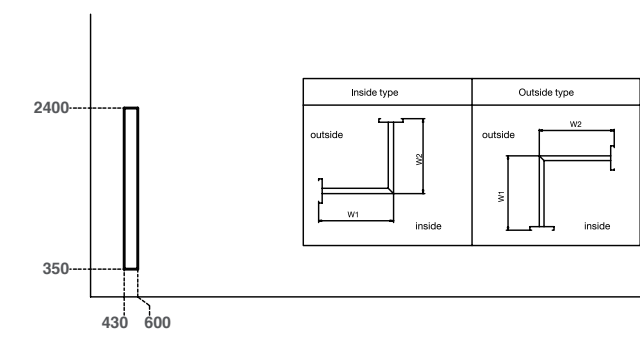

## SLIDING DOOR (2 PANELS ON 2 TRACKS)



- Sill options (standard & floor finish)
- Inside insect screen available

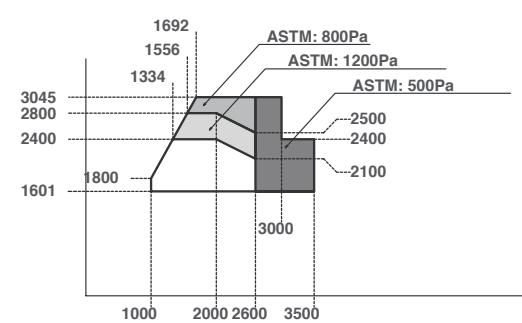

## SLIDING DOOR (4 PANELS ON 2 TRACKS)



- Sill options (standard & floor finish)
- Inside insect screen available

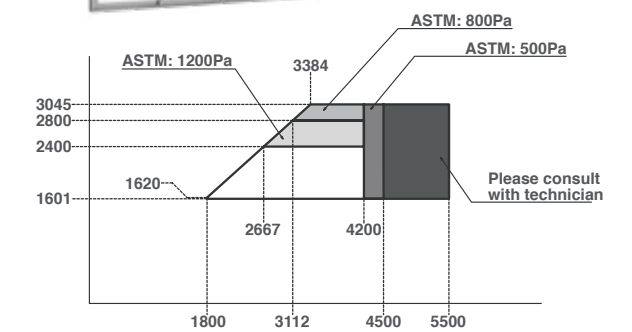



**SLIDING DOOR (3 PANELS ON 3 TRACKS)**



- Sill options (standard & floor finish)
- Inside insect screen available

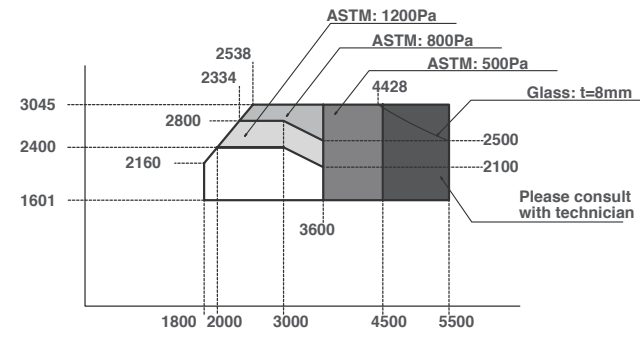

**SLIDING DOOR (6 PANELS ON 3 TRACKS)**

- Sill options (standard & floor finish)
- Inside insect screen available

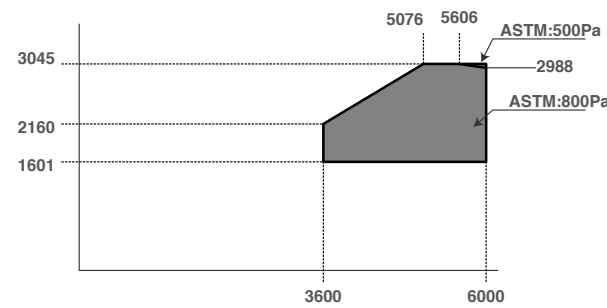

**OUT – SWING DOOR (SINGLE)**



- Select from L/R
- Sill option (with/without sill)
- Door closer (optional)
- \* in case of non-sill, no air and water performance determined

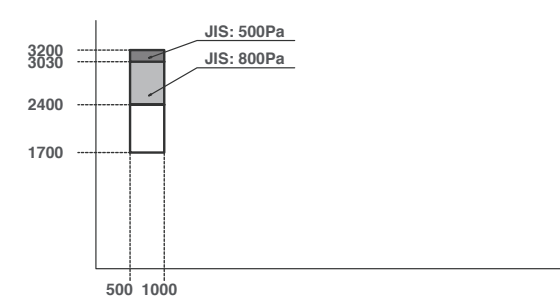

**OUT-SWING DOOR (DOUBLE)**



- Select from L/R
- Sill option (with/without sill)
- Door closer (optional)
- \* in case of non-sill, no air and water performance determined

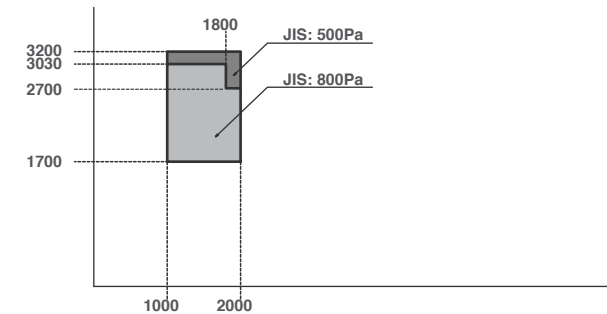

**IN-SWING DOOR (SINGLE)**



- Select from L/R
- Door closer (optional)
- Only available with Non-sill
- No water & air-tightness performance determined

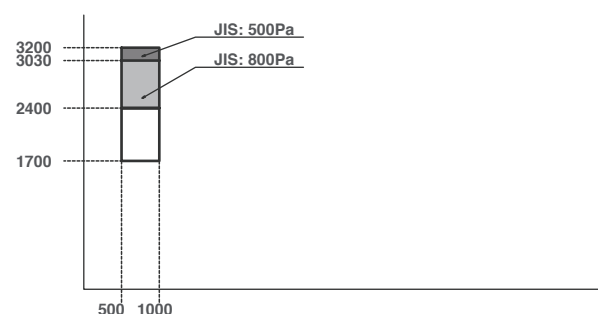

**IN-SWING DOOR (DOUBLE)**



- Select from L/R
- Door closer (optional)
- Only available with Non-sill
- No water & air-tightness performance determined

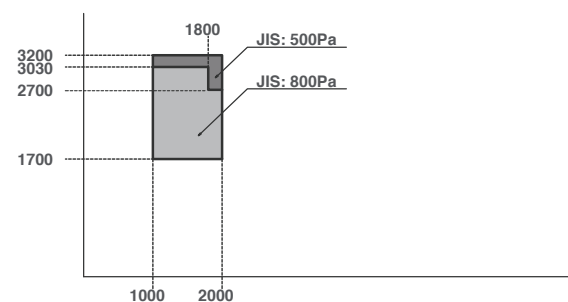

**MIXED & COMBINATION WINDOW**

- Mullions and transoms are available for each windows and doors, Please consult with our sales representative for selection
- 180° mullion (standard and reinforced)
- 90° mullion (only for outward corner)
- Transom (standard and reinforced)

UNIT WINDOWS

Bottom Windows	Top Windows		
	Single Awning	Single Casement	1 Panel Fix
SINGLE AWNING			•
SINGLE CASEMENT			•
1 PANEL FIX	•	•	•

**WE 70**

- WINDOW
- DOOR
- OPTION
- MIX

- Airflow slots are available for windows only
- Windows on top of airflow slot shall be less than 25Kg.
- Maximum length of airflow slot is 1500mm (For windows wider than 1500mm, use 2 or 3 airflow slots)

**SLIDING WINDOW (4 PANELS ON 2 TRACKS)**



- Internal insect screen available
- External insect screen available with a special order

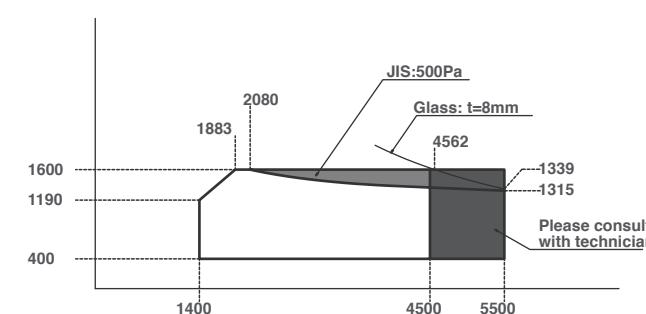

**AWNING WINDOW**



- Insect Screen available

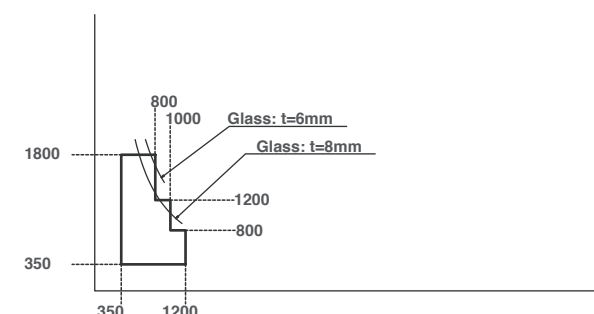

**SLIDING WINDOW (2 PANELS ON 2 TRACKS)**



- Internal insect screen available
- External insect screen available with a special order
- Single sliding available (L/R)

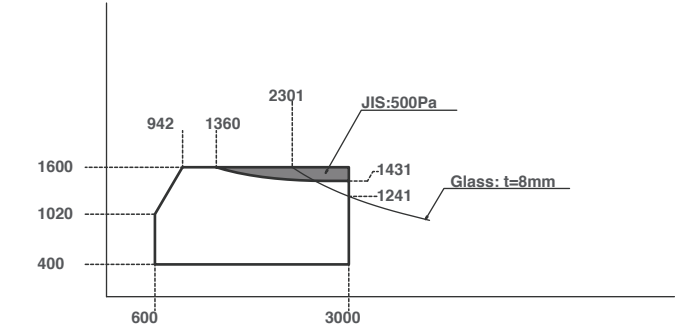

**SLIDING WINDOW (3 PANELS ON 2 TRACKS) SFS**



- Internal insect screen available
- External insect screen available with a special order

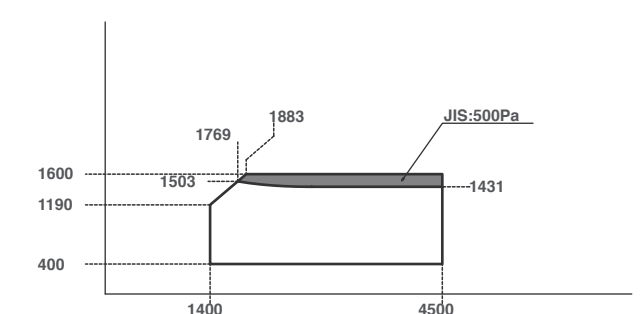

**CASEMENT WINDOW**



- Select from L/R
- Insect screen available

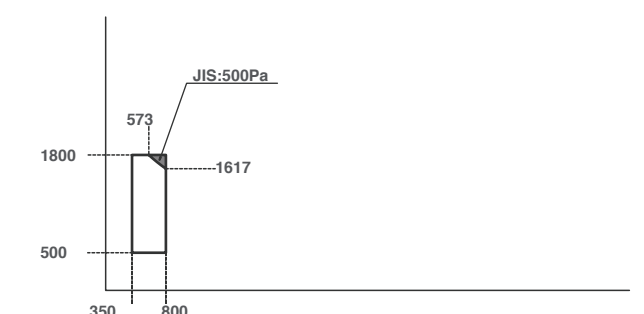

DOUBLE CASEMENT WINDOW



- Insect Screen available

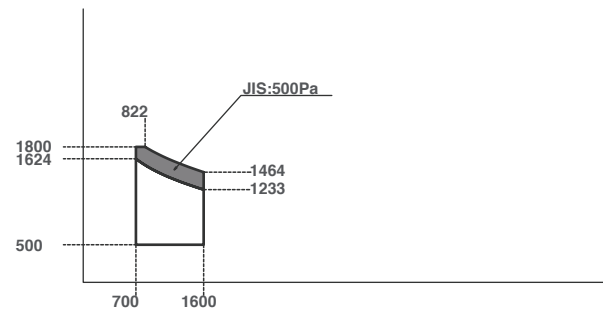

FIXED WINDOW



- Up to 4 fixed windows with unitized mullion
- Wind load performance varies by glass thickness Please consult with our technician

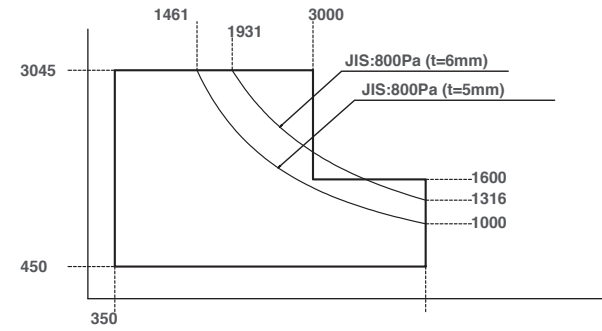

SLIDING DOOR (3 PANELS ON 2 TRACKS) SFS



- Sill options (standard & floor finish)
- Insect screen available (internal)

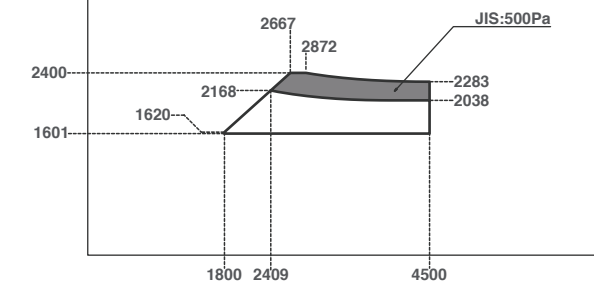

SLIDING DOOR (3 PANELS ON 3 TRACKS)



- Sill options (standard & floor finish)
- Insect screen available (internal)

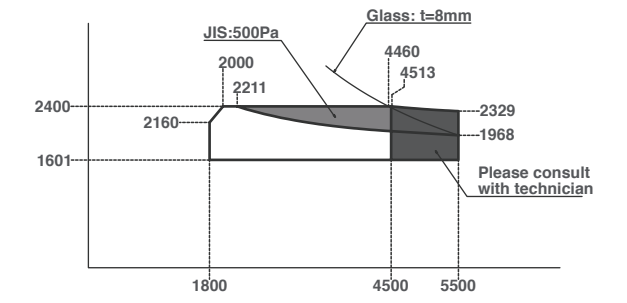

CORNER FIXED WINDOW



- Both In/outward corner available
- Middle bar (optional)

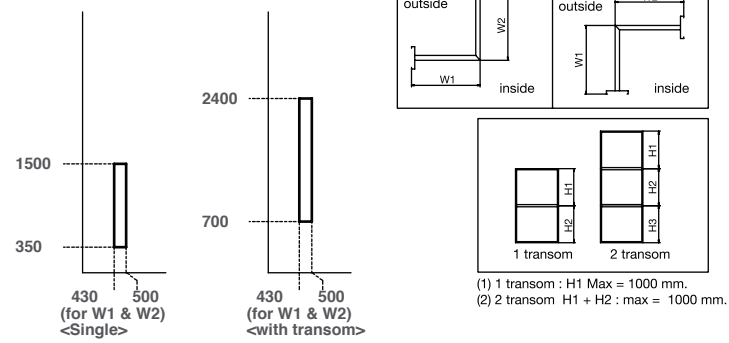

ALUMINUM LOUVER



- No performance determined

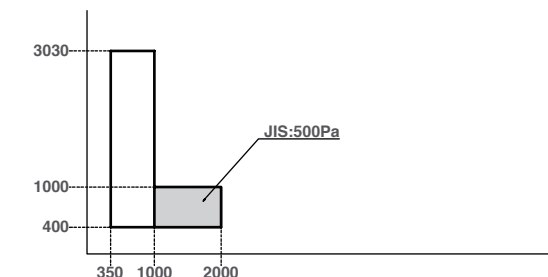

SLIDING DOOR (6 PANELS ON 3 TRACKS)



- Sill options (standard & floor finish)
- Insect screen available (internal)

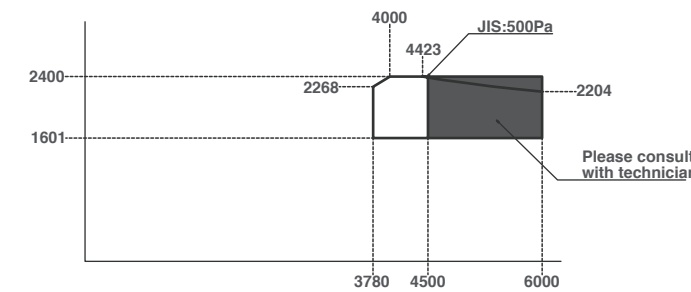

AIRFLOW DOOR



- Select from L/R
- Door closer (optional)
- Lattice with screen available

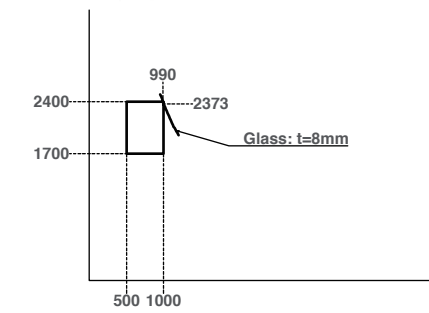

SLIDING DOOR (2 PANELS ON 2 TRACKS)



- Sill options (standard & floor finish)
- Single sliding available (L/R)
- Insect screen available (internal)

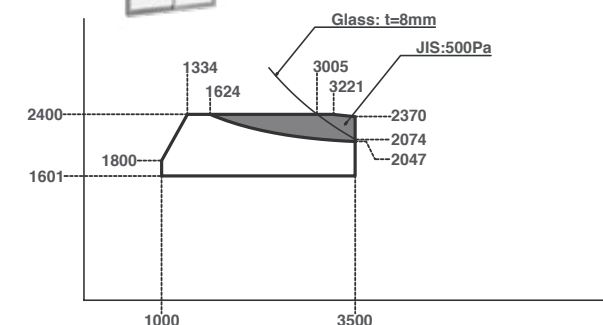

SLIDING DOOR (4 PANELS ON 2 TRACKS)



- Sill options (standard & floor finish)
- Insect screen available (internal)

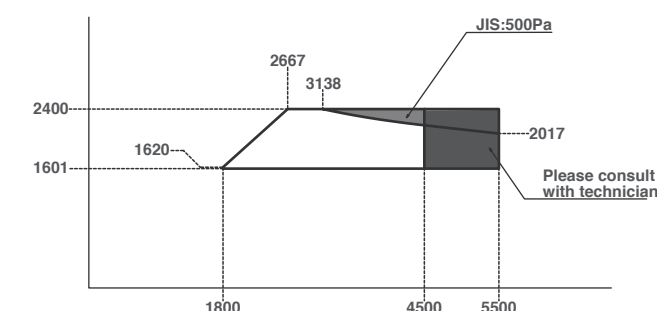

OUT-SWING DOOR (SINGLE)



- Select from L/R
  - Sill option (with/without sill)
  - Door closer (optional)
  - Insect screen available with louver door
- \* in case of non-sill, no air and water performance determined

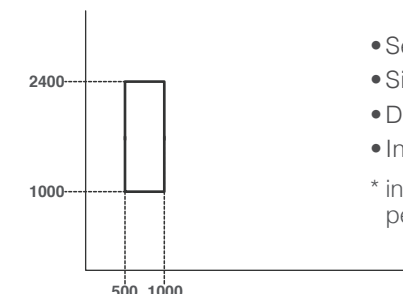

OUT-SWING DOOR (DOUBLE)



- Select from L/R
  - Sill option (with/without sill)
  - Door closer (optional)
  - Insect screen available with louver door
- \* in case of non-sill, no air and water performance determined

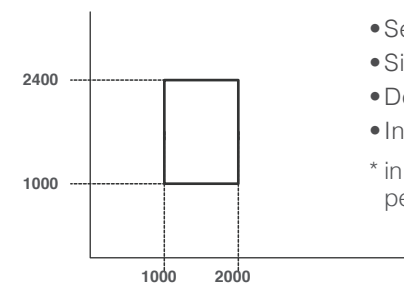



**IN-SWING DOOR (SINGLE)**

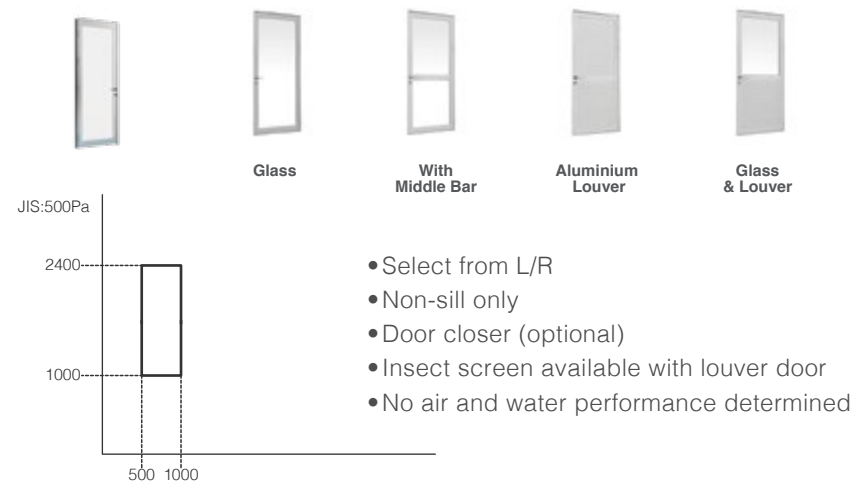

**IN-SWING DOOR (DOUBLE)**

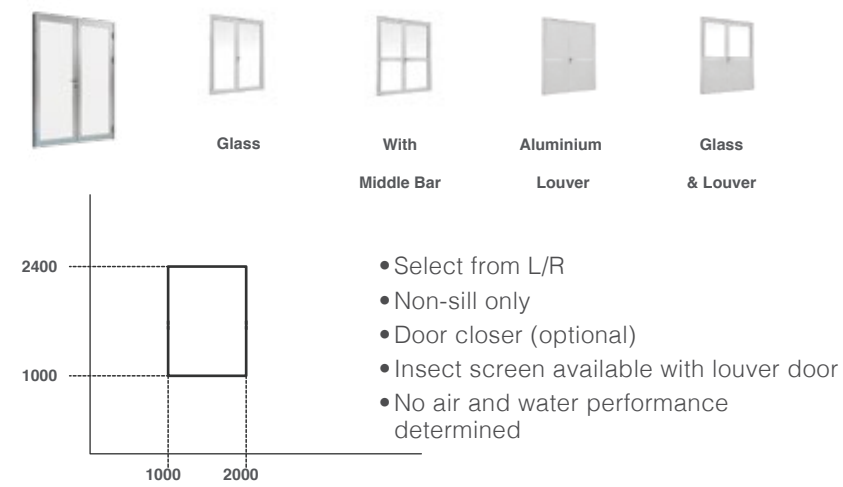

**ENTRANCE SLIDING DOOR (2 PANELS ON 2 TRACKS)**

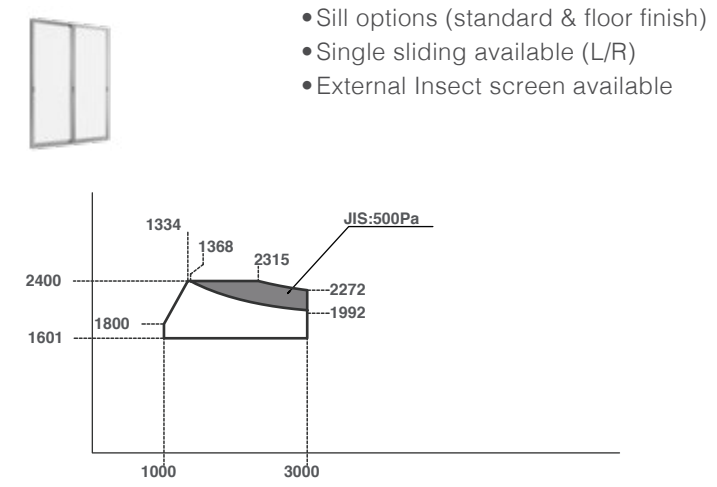

**ENTRANCE SLIDING DOOR (4 PANELS ON 2 TRACKS)**

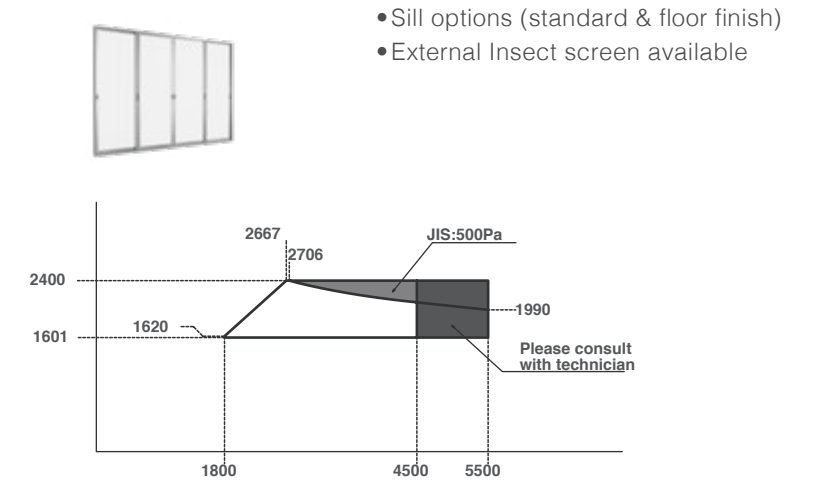

**FOLDING DOOR (4 PANELS)**

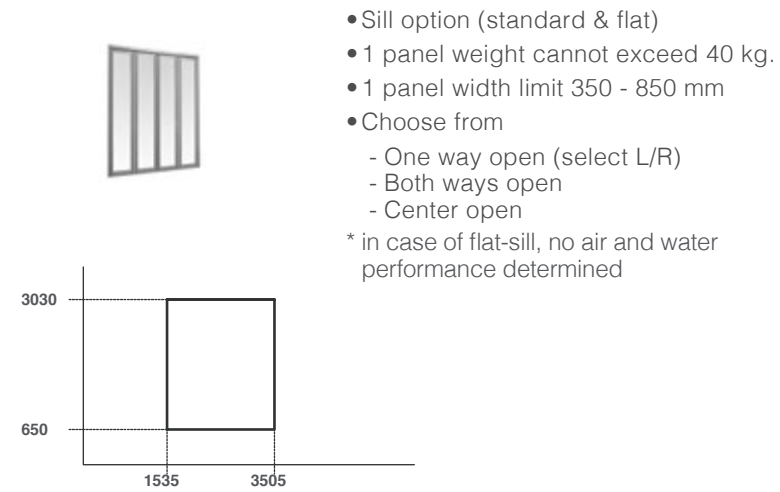

**FOLDING DOOR (6 PANELS)**

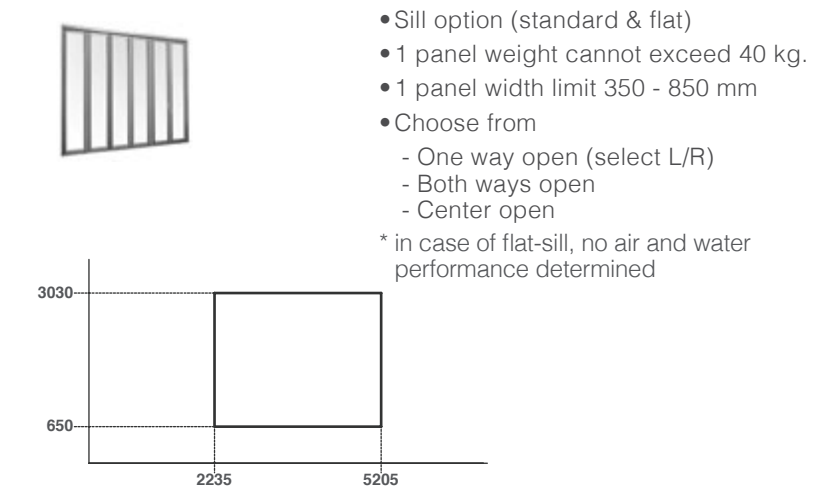

**FOLDING DOOR (8 PANELS)**

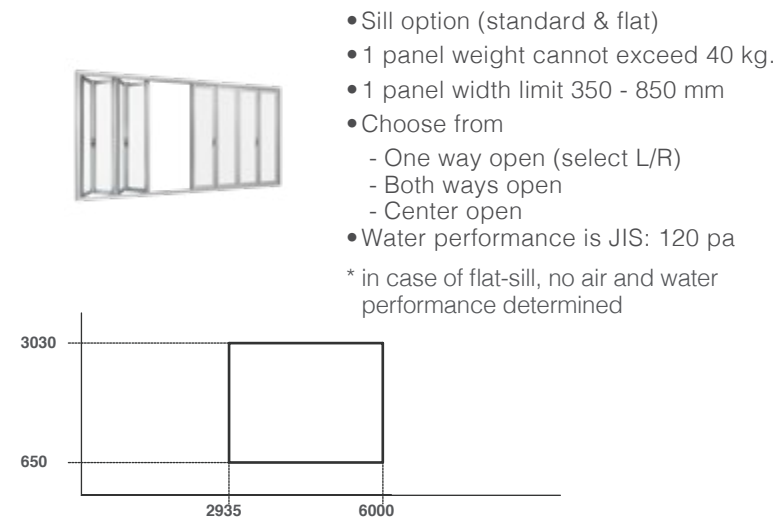

**FOLDING DOOR (12,16 PANELS)**

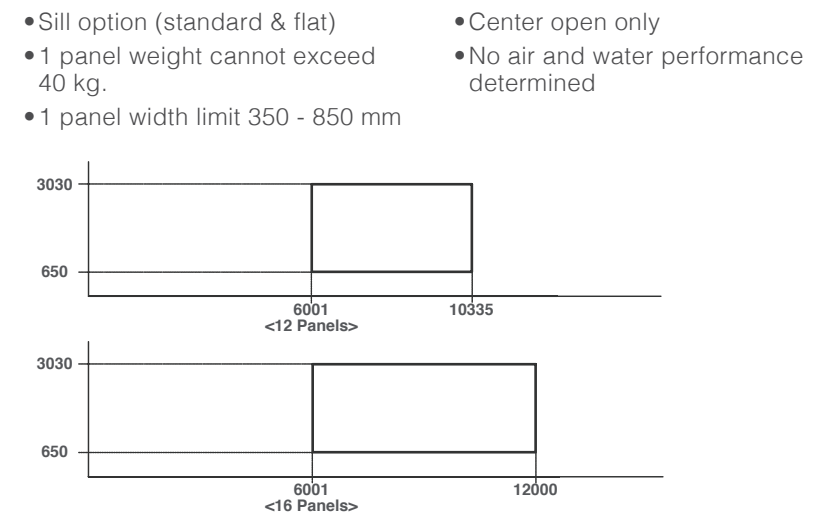

**MIXED & COMBINATION WINDOW**

- Mullions and transoms are available for each windows and door, please consult with our sales representative for selection
- 180o mullion (standard)
- 90o mullion (only for outward corner)
- Transom (standard)

UNIT WINDOWS

BOTTOM WINDOWS	TOP WINDOWS											
	Sliding Window (2 Panels on 2 Tracks)	Sliding Window (4 Panels on 2 Tracks)	Sliding Window (3 Panels on 2 Tracks) SFS	Single Awning	Single Casement	Double Casement	1 Panel Fix	2 Panels Fix	3 Panels Fix	4 Panels Fix	Outward-Corner Fix	Inward-Corner Fix
SLIDING WINDOW (2 PANELS ON 2 TRACKS)							•	•				
SLIDING WINDOW (4 PANELS ON 2 TRACKS)								•	•	•		
SLIDING WINDOW (3 PANELS ON 2 TRACKS) SFS								•	•	•		
SINGLE AWNING							•					
SINGLE CASEMENT							•					
DOUBLE CASEMENT							•	•				
1 PANEL FIX	•			•	•	•	•					
2 PANELS FIX	•	•	•			•		•	•	•		
3 PANELS FIX		•	•				•	•	•	•		
4 PANELS FIX		•	•				•	•	•	•		
OUTWARD-CORNER FIX											•	
INWARD-CORNER FIX												•

UNIT DOORS

BOTTOM DOORS	TOP WINDOWS			
	1 Panel Fix	2 Panels Fix	3 Panels Fix	4 Panels Fix
SLIDING DOOR (2 PANELS ON 2 TRACKS)	•	•		
SLIDING DOOR (4 PANELS ON 2 TRACKS)		•	•	•
SLIDING DOOR (3 PANELS ON 2 TRACKS) SFS		•	•	•
2 PANELS FIX		•	•	•
3 PANELS FIX		•	•	•
4 PANELS FIX		•	•	•
SWING DOOR (SINGLE)	•			
SWING DOOR (DOUBLE)		•		

# WE 40

WINDOW

CENTER SLIDING WINDOW



- External fixed insect screen available

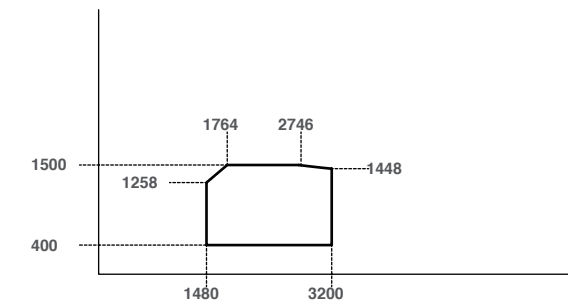

CASEMENT WINDOW



- Insect screen NOT available

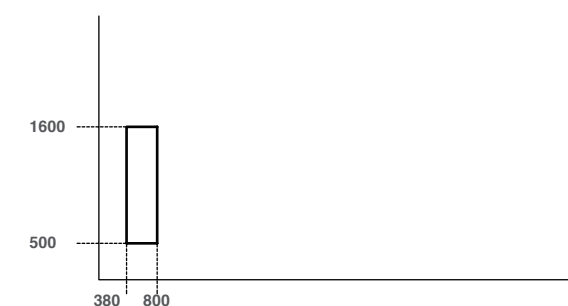

SINGLE SLIDING WINDOW



- Select from L/R
- External fixed insect screen available

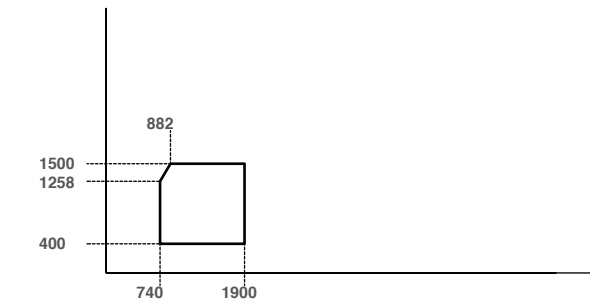

AWNING WINDOW



- Insect screen NOT available

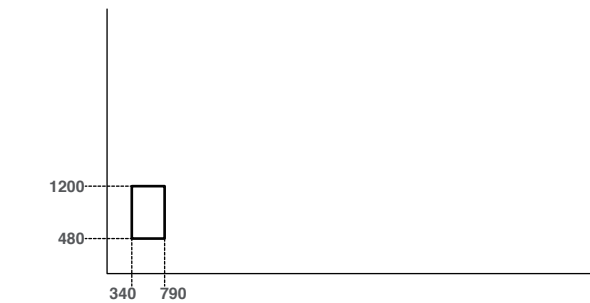

FIXED WINDOW



- Wind load performance varies by glass thickness. Please consult with our technician

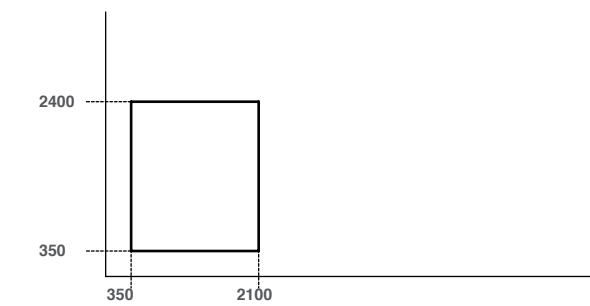





**WE SERIES  
PROJECT REFERENCE**  
MALTON GATES, THAILAND



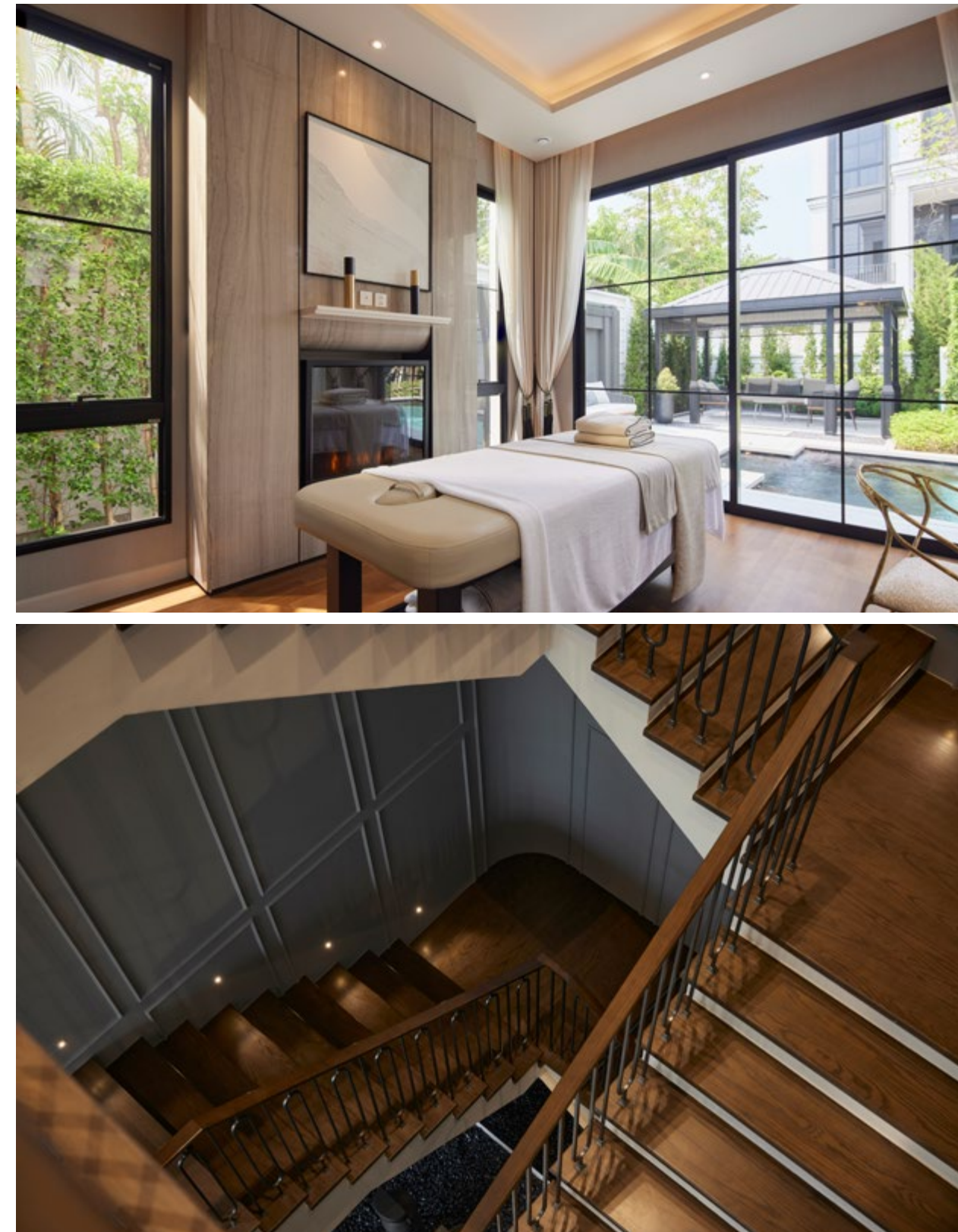





**INTERIOR  
series**

# INTERIOR series

INTERIOR Series, a luxurious and durable choice to divide interior living spaces. Available are the hanging type without floor track, sliding type with floor track, and swing type. Slim design Aluminum profiles give a modern accent to your space.

## SPECIFICATIONS

		HANGING DOOR	PARTITION DOOR
Frame Depth	1 track	Top 47.2 mm Jamb 49.1 mm	72 mm (2 tracks)
	2 tracks	Top 88.5 mm Jamb 90.4 mm	104 mm (3 tracks)
Height of Sill		No sill	20 mm
Glass Thickness		5, 6, 8 mm	5, 6, 8 mm

## COLOR



NATURAL WHITE



NATURAL SILVER



SHINE GRAY



AUTUMN BROWN



DUSK GRAY



NATURAL BLACK

## FEATURES

EFFORTLESS MOVEMENT



SAFETY



## UNIQUE FEATURES

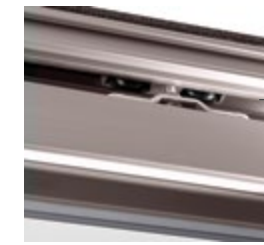

DURABLE ROLLERS FOR SMOOTH OPERATION



SOFT CLOSE FOR EXTRA SAFETY (OPTION)



PULL (STANDARD)



HANDLE & LOCK-SET (OPTION IN SILVER ONLY)



SILL-LESS DESIGN PROVIDES SAFETY AND COMFORT FOR ALL



PANEL GUIDE PIECE TO PREVENT PANEL FROM SHAKING WHEN SLIDING

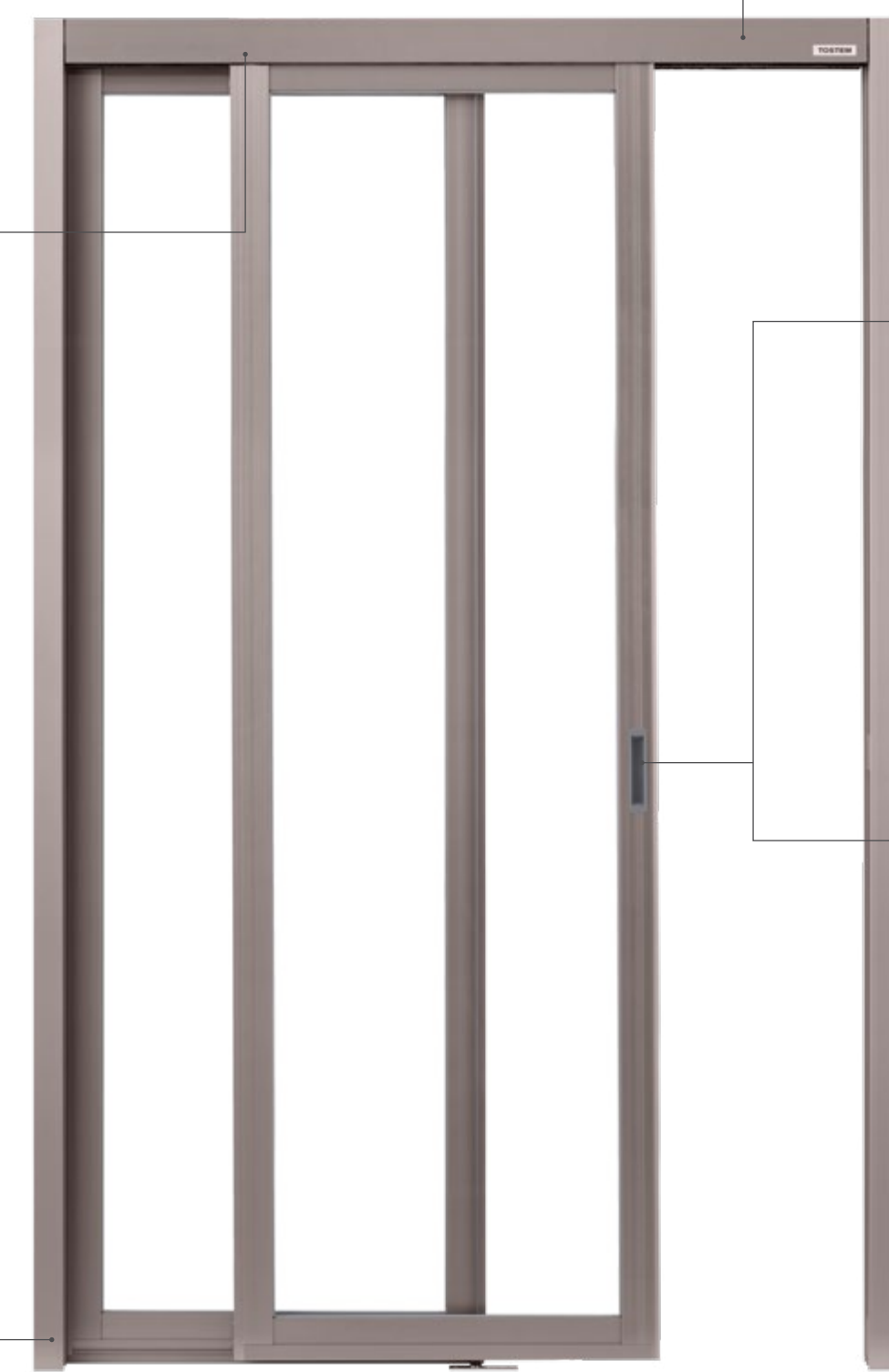



# INTERIOR series

- WINDOW
- DOOR
- OPTION
- MIX

## ON-WALL HANGING DOOR (1 PANEL ON 1 TRACK)

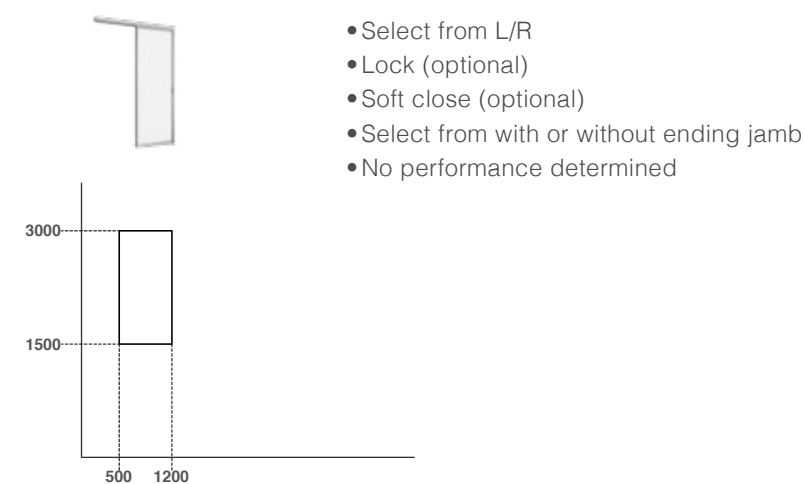

## IN-WALL HANGING DOOR (1 PANEL ON 1 TRACK)

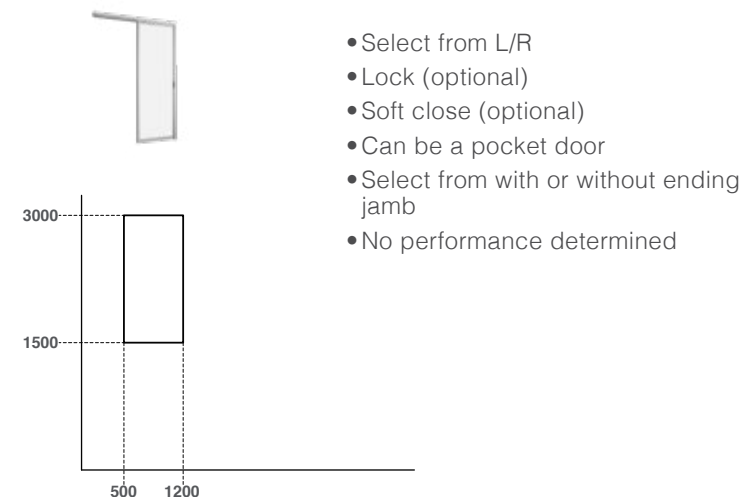

## ON-WALL HANGING DOOR (2 PANELS ON 1 TRACK)

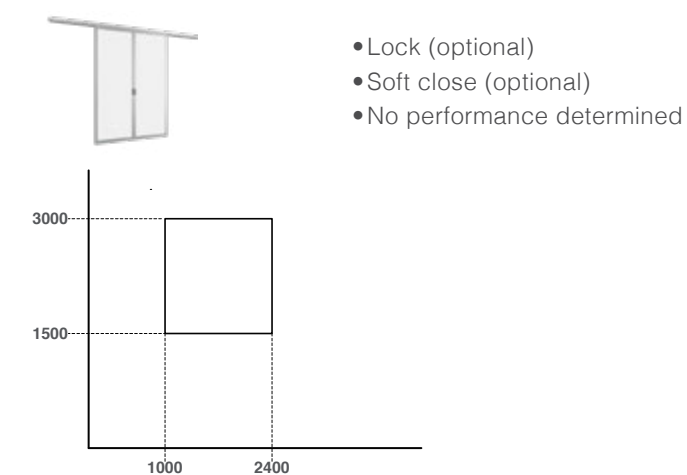

## HANGING DOOR (2 PANELS ON 2 TRACKS)

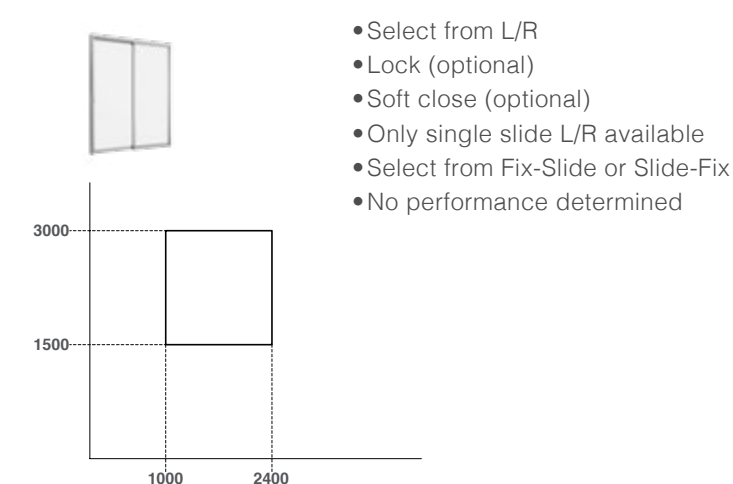

## PARTITION DOOR (2 PANELS ON 2 TRACKS)

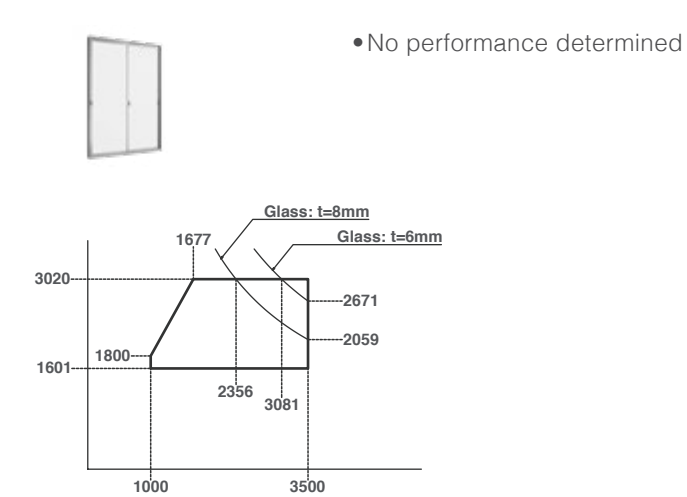

## PARTITION DOOR (3 PANELS ON 3 TRACKS)

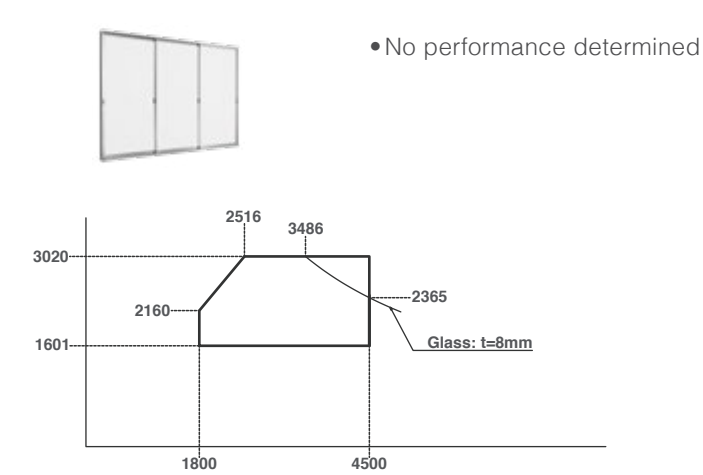

## PARTITION DOOR (4 PANELS ON 2 TRACKS)

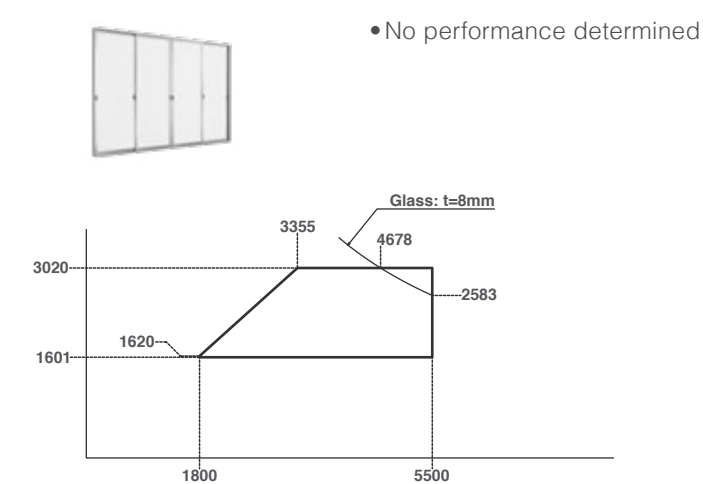

## PARTITION DOOR (6 PANELS ON 3 TRACKS)

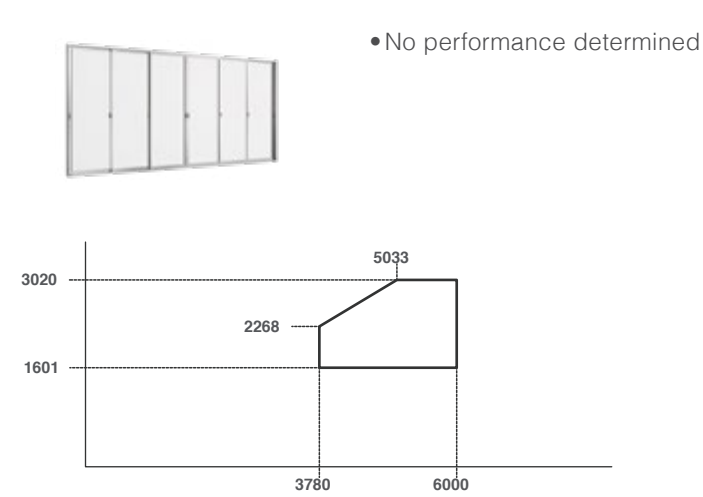



**ENTRANCE  
DOOR**





# GIESTA Series

High quality wood-pattern or metallic finish-doors equipped with user-friendly handle with high security lock system gives better convenience to both family and visitors and make us feel glad to be home.

## UNIQUE FEATURES

### SPECIFICATIONS

<b>FRAME DEPTH</b>	101.6 MM
<b>HEIGHT OF SILL</b>	OUT-SWING 50 MM
	IN-SWING OUTSIDE 30 / INSIDE 14 MM
<b>DOOR FRAME</b>	TOP AND SIDE FRAME <ul style="list-style-type: none"> <li>WOOD PATTERN TYPE: WOOD PATTERN RESIN SHEET, WRAPPING ON ALUMINUM PROFILE WITH SYNTHETIC RUBBER</li> <li>PAINTED TYPE : ANODIZED ALUMINUM PROFILE</li> </ul>
	SILL ANODIZED ALUMINUM PROFILE
<b>DOOR PANEL</b>	EXTERNAL SHEET <ul style="list-style-type: none"> <li>WOOD PATTERN TYPE : (EXTERNAL) RESIN LAMINATED SHEET/ (INTERNAL) ANTI-RUST EPOXY COATING</li> <li>POLYSTYRENE (EPS FOAM)</li> </ul>
	INSULATING GLASS THICKNESS 23 MM (CLEARED 3+AIR GAP 16+PATTERNED GLASS 4)

### PERFORMANCES

WIND PRESSURE



S-2 (1200PA)  
(JIS A 1515)

WATER TIGHTNESS



W-2 (150PA)  
(JIS A 1517)

AIR TIGHTNESS



A-4 (2)  
(JIS A 1516)

NOISE INSULATION



N/A  
(JIS A 1416)



# Simple and Minimalistic



P01

P02

P03

## COLORS



TURIN PINE

CREA MOCHA

CREA RUSK

TEAK



POLISH SILVER



SILKY WHITE



AUTUMN BROWN

	WOOD PATTERN	IN-SWING (NO SILL)	IN-SWING	OUT-SWING
Single				
With Sidelight	<p>Width of sidelight [SW]  <math>1034 \leq W \leq 1248 : SW = 304</math>  <math>1249 \leq W \leq 1438 : SW = 346</math></p>			
Double				

	ALUMINUM PATTERN	IN-SWING (NO SILL)	IN-SWING	OUT-SWING
Single				
With Sidelight	<p>Width of sidelight [SW]  <math>1034 \leq W \leq 1248 : SW = 304</math>  <math>1249 \leq W \leq 1438 : SW = 346</math></p>			
Double				

\* A, B, C indicates price changing points. (A<B<C)



# Modern but Traditional



D01

D02

D03

## COLORS



TURIN PINE



CREA MOCHA

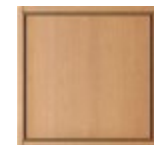

CREA RUSK



TEAK

	WOOD PATTERN	IN-SWING (NO SILL)	IN-SWING	OUT-SWING
Single				
With Sidelight	<p>Width of sidelight [SW]  <math>1034 \leq W \leq 1248 : SW = 304</math>  <math>1249 \leq W \leq 1438 : SW = 346</math></p>			
Double				

	ALUMINUM PATTERN	IN-SWING (NO SILL)	IN-SWING	OUT-SWING
Single		N/A	N/A	N/A
With Sidelight	<p>Width of sidelight [SW]  <math>1034 \leq W \leq 1248 : SW = 304</math>  <math>1249 \leq W \leq 1438 : SW = 346</math></p>	N/A	N/A	N/A
Double		N/A	N/A	N/A

\* A, B, C indicates price changing points. (A<B<C)

# Glass with Style



G01 G02 G03 G04

## COLORS



TURIN PINE CREA MOCHA CREA RUSK TEAK



POLISH SILVER SILKY WHITE AUTUMN BROWN

	WOOD PATTERN	IN-SWING (NO SILL)	IN-SWING	OUT-SWING
Single				
With Sidelight	 Width of sidelight [SW] $1034 \leq W \leq 1248 : SW = 304$ $1249 \leq W \leq 1438 : SW = 346$			
Double				

\* Dimension indicated in ( ) are the minimum dimension for G01 design

	ALUMINUM PATTERN	IN-SWING (NO SILL)	IN-SWING	OUT-SWING
Single				
With Sidelight	 Width of sidelight [SW] $1034 \leq W \leq 1248 : SW = 304$ $1249 \leq W \leq 1438 : SW = 346$			
Double				

\* A, B, C indicates price changing points. (A<B<C)  
Aluminum pattern not available for G01



# Comfort with Minimal design



A01

## COLORS



TURIN PINE







CREA MOCHA



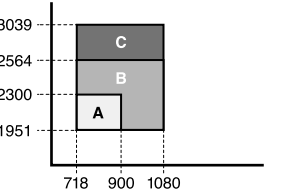
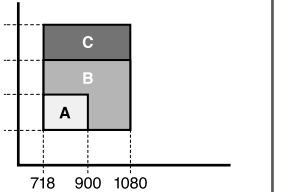

CREA RUSK

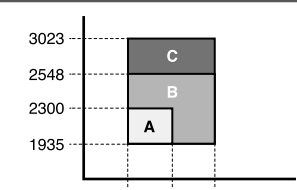
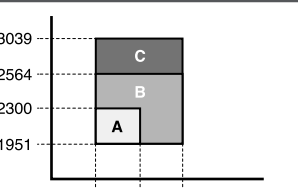
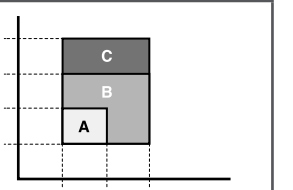

TEAK

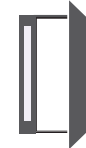
WOOD PATTERN	IN-SWING (NO SILL)	IN-SWING	OUT-SWING
Single 			
With Sidelight Width of sidelight [SW] $1034 \leq W \leq 1248 : SW = 304$ $1249 \leq W \leq 1438 : SW = 346$  			
Double 	N/A	N/A	N/A

ALUMINUM PATTERN	IN-SWING (NO SILL)	IN-SWING	OUT-SWING
Single 	N/A	N/A	N/A
With Sidelight Width of sidelight [SW] $1034 \leq W \leq 1248 : SW = 304$ $1249 \leq W \leq 1438 : SW = 346$  	N/A	N/A	N/A
Double 	N/A	N/A	N/A

\* A, B, C indicates price changing points. (A<B<C)

# GIESTA AIRFLOW

## A PERFECT SOLUTION FOR YOUR OWN COMFORT WITH MINIMAL DESIGN

The GIESTA AIRFLOW series offers a high-performance wooden pattern steel door with an integrated AIRFLOW window and insect screen. It allows for air circulation to cool the living space, reduce humidity, and remove unpleasant odors. The ventilation panel is wide enough to let the air flow in easily but too small to be entered from, providing added security with a multi-lock function. GIESTA AIRFLOW is Japanese Industrial Standards (JIS) certified and has won Japan's KIDS Design Award for its user-friendly and child safety design.



Provide passive ventilation environment



Complete air flow with security



Keep mosquito and pest away from your home

## SIMPLE OPEN/ CLOSE OPERATION

AIRFLOW window is swing-in and can lock and unlock easily by using single lock handle to control 2 locks (Multi-lock). Open-close smoothly with high performance hinge.



LIFT LOCK HANDLE TO UNLOCK



PULL DOWN LOCK HANDLE FOR VENTILATION

## EASY TO CLEAN

Deep clean every corner without removing any part by spraying water from garden hose to insect screen from outside the room (please make sure that the AIRFLOW window and the door is completely closed)





UNIQUE FEATURES

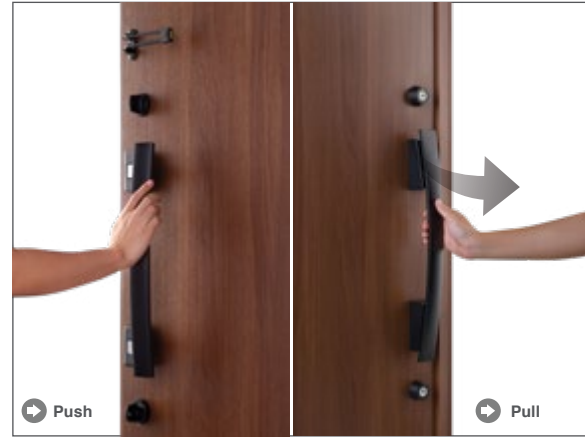

Push-Pull bar handle easy to operate just push or pull after unlock to open the door

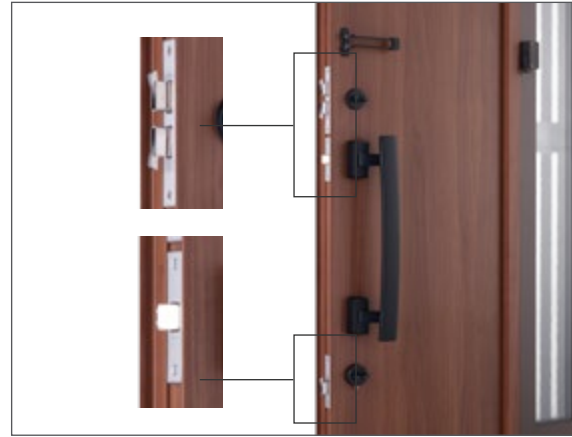

2 locks that control 3 latches

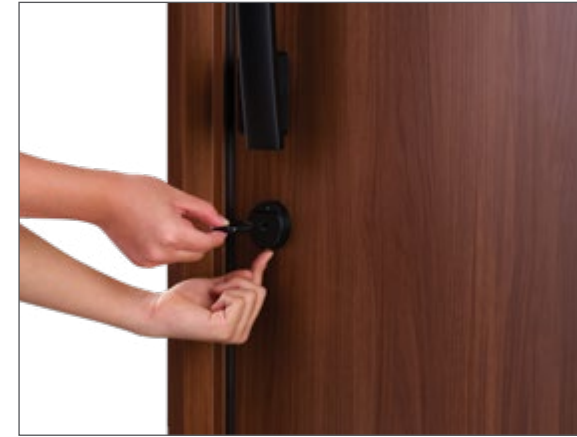

Remove inside key head to prevent from unlock in case of burglary



Lock-unlock with ease with reversible key



Frame sealed with rubber for watertight and anti-pinch



Door filled with insulation material for heat prevention and noise insulation



# Handles

BAR HANDLE TYPE A		BAR HANDLE TYPE F		LEVER HANDLE TYPE K		LEVER HANDLE TYPE L	
OUTSIDE	INSIDE	OUTSIDE	INSIDE	OUTSIDE&INSIDE		OUTSIDE&INSIDE	
BLAST SILVER	SILKY MATTE BLACK	BLAST SILVER	SILKY MATTE BLACK	BLAST SILVER	SATIN GOLD	BLAST SILVER	SILKY MATTE BLACK
Apply for Out-Swing door only		Apply for Out-Swing door only		Apply for both Out-Swing and In-Swing door		Apply for both Out-Swing and In-Swing door	

DIGITAL HANDLE		DIGITAL HANDLE		BAR HANDLE TYPE V	
OUTSIDE	INSIDE	OUTSIDE	INSIDE	OUTSIDE	INSIDE
SILVER	BLACK	SILVER	BLACK	SILVER	BLACK
Apply for both Out-Swing and In-Swing door		Apply for Out-Swing door only		Apply for In-Swing door only	

# Accessories

## OUT-SWING DOOR

DOOR CLOSER	
AUTUMN BROWN	SHINE GRAY
NATURAL WHITE	
ALUMINUM	

DOOR GUARD	
BLAST SILVER	SATIN GOLD
SILKY MATTE BLACK	
ALUMINUM	

## IN-SWING DOOR

DOOR CLOSER	
AUTUMN BROWN	SHINE GRAY
ALUMINUM	

DOOR GUARD	
SILVER	
ALUMINUM	

## CYLINDER LOCK & KEY

CYLINDER LOCK	
OUTSIDE	INSIDE
THUMB TURN IS IN HANDLE BOX CYLINDER CONSTRUCTION KEYS: 3 OWNER KEYS: 5	
BLAST SILVER	SATIN GOLD
SILKY MATTE BLACK	
STEEL	





**ALUMINUM  
EXTERIOR**



# FENCE & GATE EXTERIOR

FENCE & GATE is a perfect fencing choice for your residence.

Our fence and gate solutions will enhance the look, feel and overall value of your property, while providing safety and security your family.











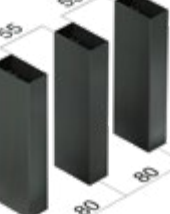
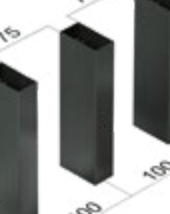
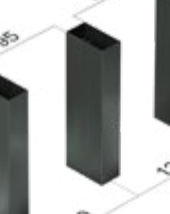

## FEATURES

-  ULTRA LIGHTWEIGHT
-  IMPACT TEST
-  EFFORTLESS MOVEMENT
-  LOW MAINTENANCE
-  ANTI-RUST DURABILITY

## COLOR

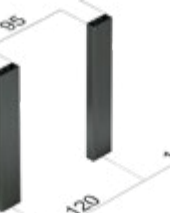

## LATTICE PATTERN

SHAPE OF LATTICE	PITCH 60	PITCH 80	PITCH 100	PITCH 120	PITCH 140
Sliding gate 					
Folding gate Swing gate Fence 					



# SLIDING Gate

SINGLE SLIDING GATE	MINIMUM	MAXIMUM
WIDTH (OPENING WIDTH)	2,100 MM	5,600 MM
HEIGHT (PRODUCT HEIGHT)	1,200 MM	2,000 MM

\* please see reference drawing for detail

DOUBLE SLIDING GATE	MINIMUM	MAXIMUM
WIDTH (OPENING WIDTH)	5,000 MM	8,000 MM
HEIGHT (PRODUCT HEIGHT)	1,200 MM	1,600 MM

\* please see reference drawing for detail

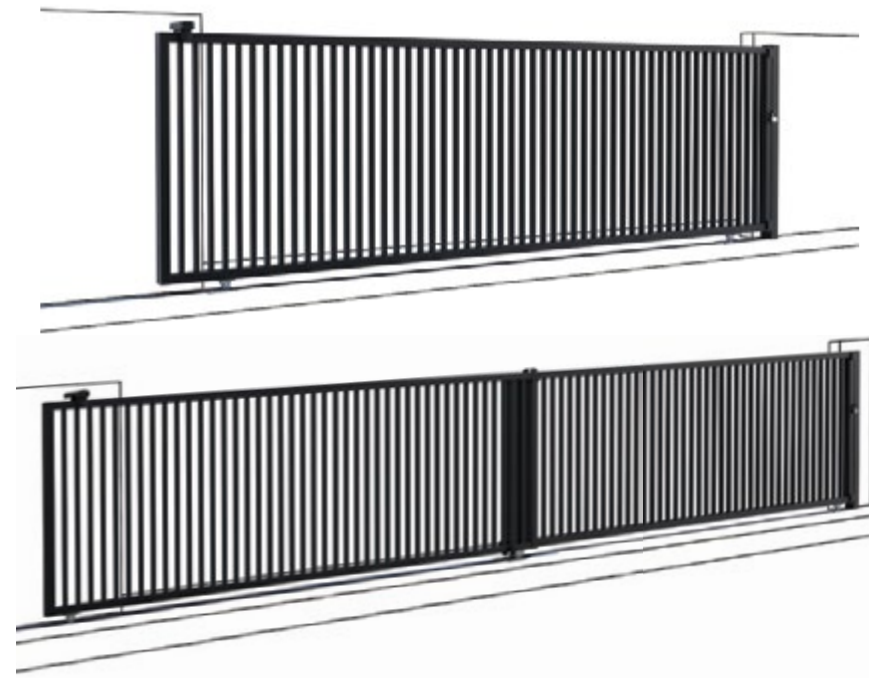

## UNIQUE FEATURES



Square pipe design provides strength and durability



Durable stainless-steel wheel and track enable light and smooth gliding.



Wheel stopper ensures stop and hold when gate is closed

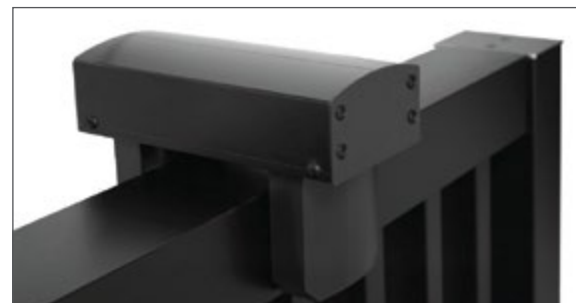

Panel guide for safety to hold panel when gliding for single panel type



Panel guide to hold both panels when gliding for safety for double panels type



# FOLDING Gate

4 PANELS FOLDING GATE	MINIMUM	MAXIMUM
WIDTH (OPENING WIDTH)	3,000 MM	4,900 MM
HEIGHT (PRODUCT HEIGHT)	1,200 MM	1,600 MM

\* please see reference drawing for detail

6 PANELS FOLDING GATE	MINIMUM	MAXIMUM
WIDTH (OPENING WIDTH)	4,300 MM	6,000 MM
HEIGHT (PRODUCT HEIGHT)	1,200 MM	1,600 MM

\* please see reference drawing for detail



## UNIQUE FEATURES



Hinges



Rollers



Drop rod

# SWING Gate

SINGLE SWING GATE	MINIMUM	MAXIMUM
WIDTH (OPENING WIDTH)	600 MM	1,100 MM
HEIGHT (PRODUCT HEIGHT)	1,200 MM	1,600 MM

\* please see reference drawing for detail

DOUBLE SWING GATE	MINIMUM	MAXIMUM
WIDTH (OPENING WIDTH)	1,080 MM	2,080 MM
HEIGHT (PRODUCT HEIGHT)	1,200 MM	1,600 MM

\* please see reference drawing for detail



## UNIQUE FEATURES



Hinges



Drop rod

# FENCE

	MINIMUM	MAXIMUM
WIDTH (OPENING WIDTH)	500 MM	2,000 MM
HEIGHT (PRODUCT HEIGHT)	600 MM	1,200 MM

\* \*please see reference drawing for detail

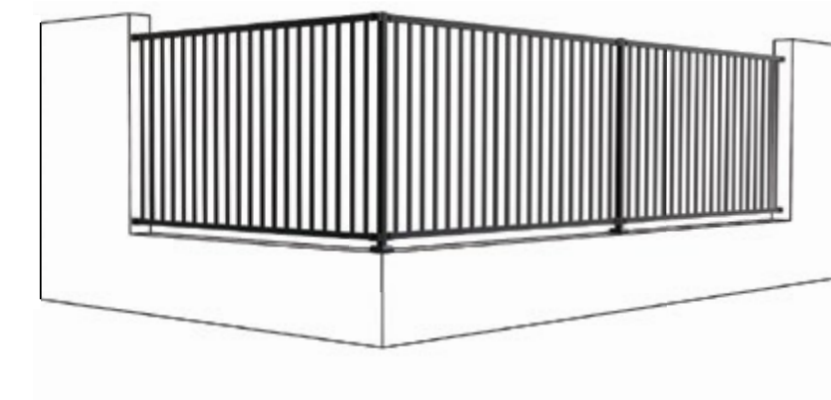

## UNIQUE FEATURES



Minimalist slim design yet sturdy. Wall anchor can be adjusted up to 7.5 mm



Straight and corner type fence jointer available. Adjustable from 90-180 degrees



Fence post with concrete surface mount with cover. Set-in-concrete type also available





**EXTERIOR PROJECT  
REFERENCE**

88 LAND AND HOUSE HILLSIDE, THAILAND



# Reference DRawings

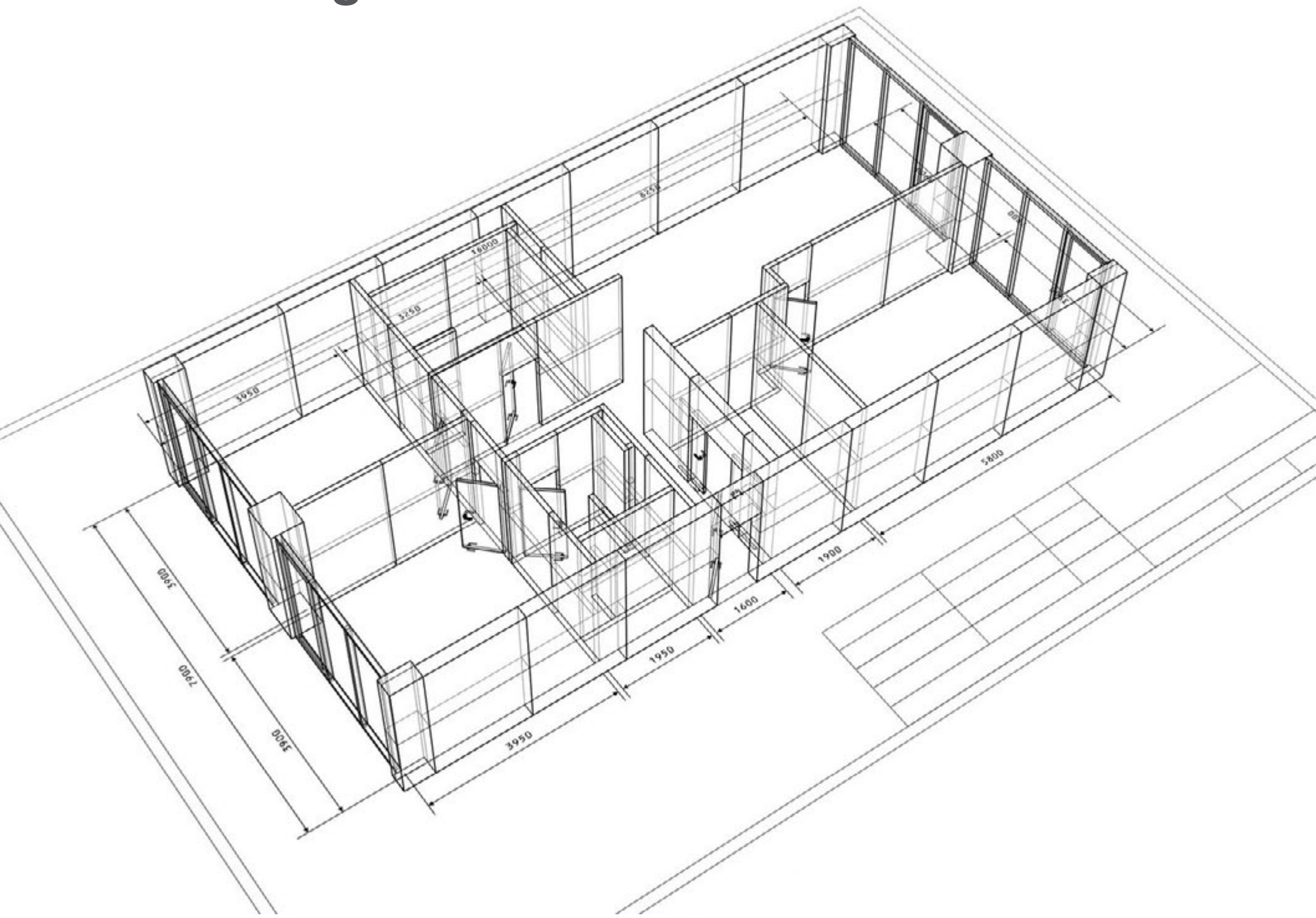

## GRANTS WINDOW SERIES

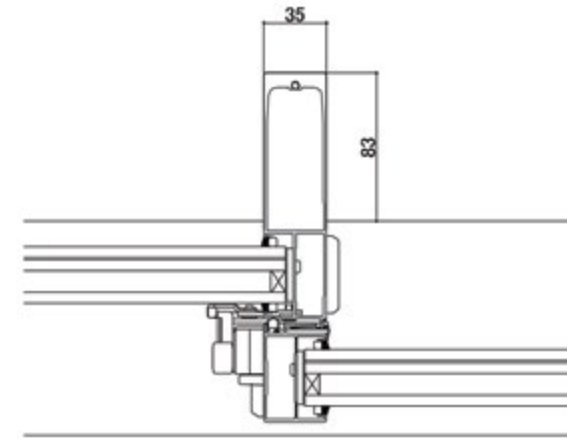

< Meeting stile detail: In case of largest openings >

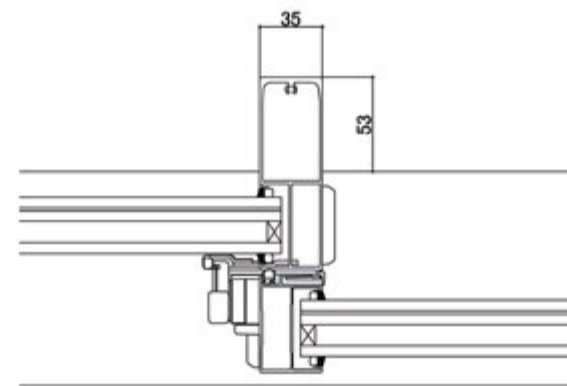

< Meeting stile detail: In case of largest openings >

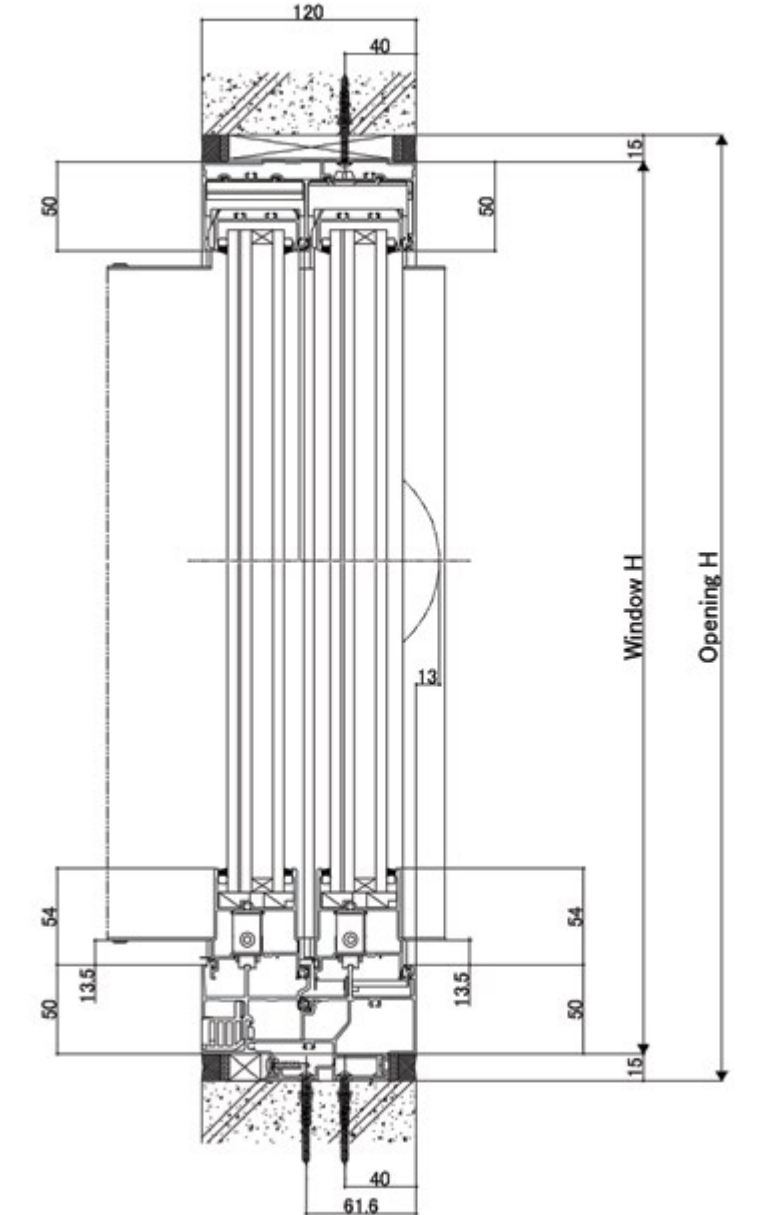

< Vertical section: 2 panels sliding window >

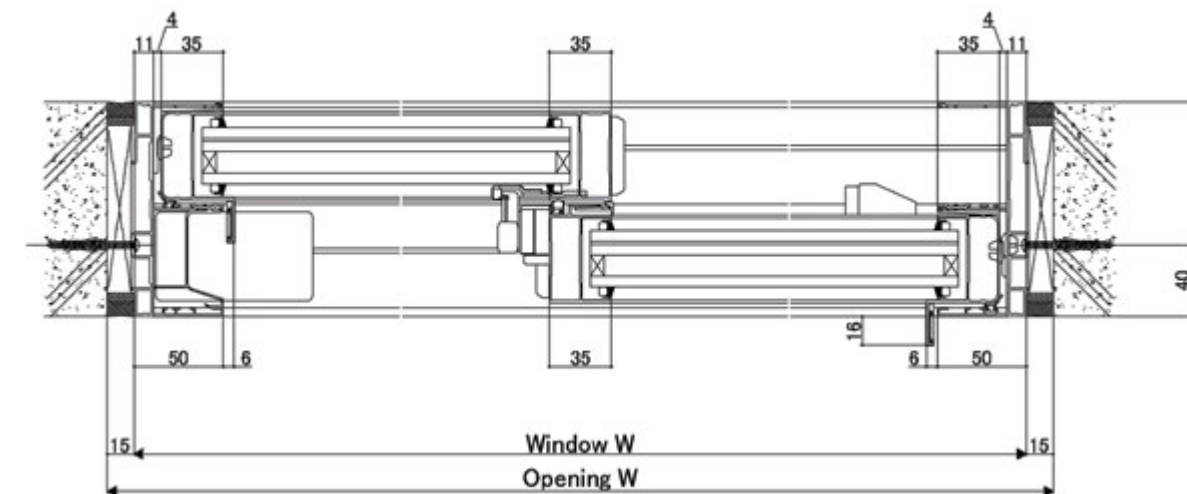

< Horizontal section: 2 panels sliding window >

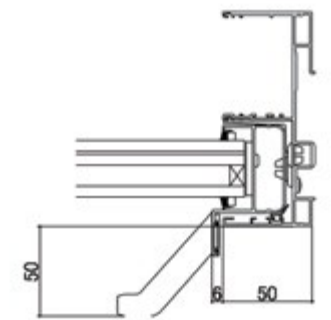

< In case with handle option >



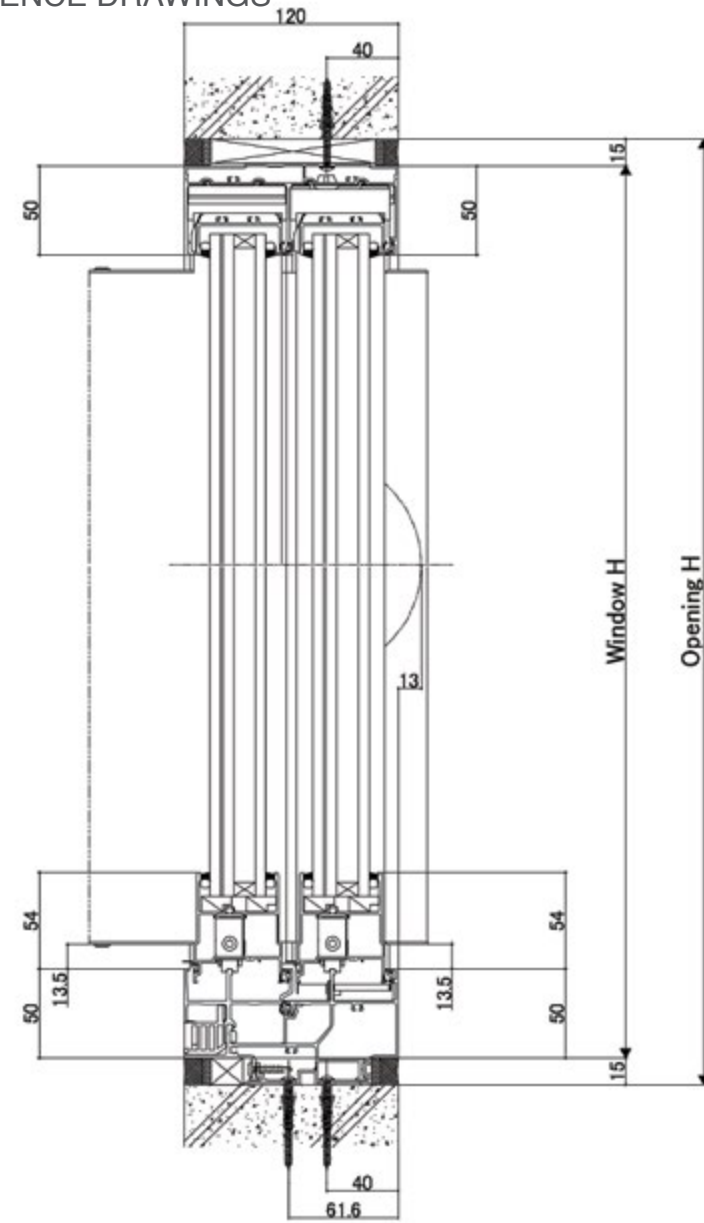

< Vertical section: 4 panels sliding window >

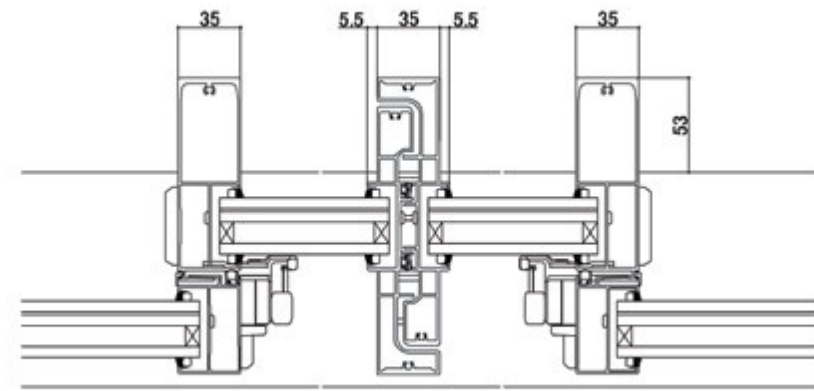

< Stiles detail: In case of large openings >

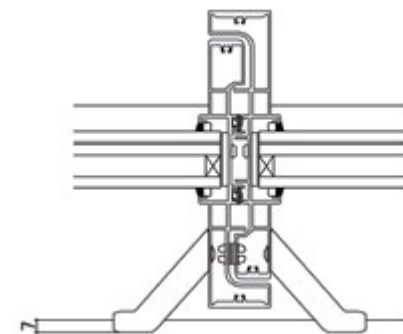

< In case with handle option > (Butting stile)

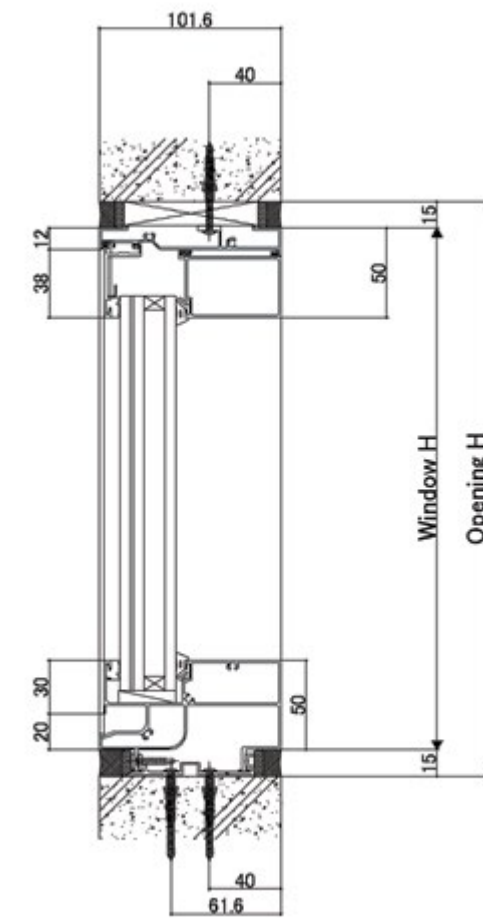

< Vertical section: Fixed window >

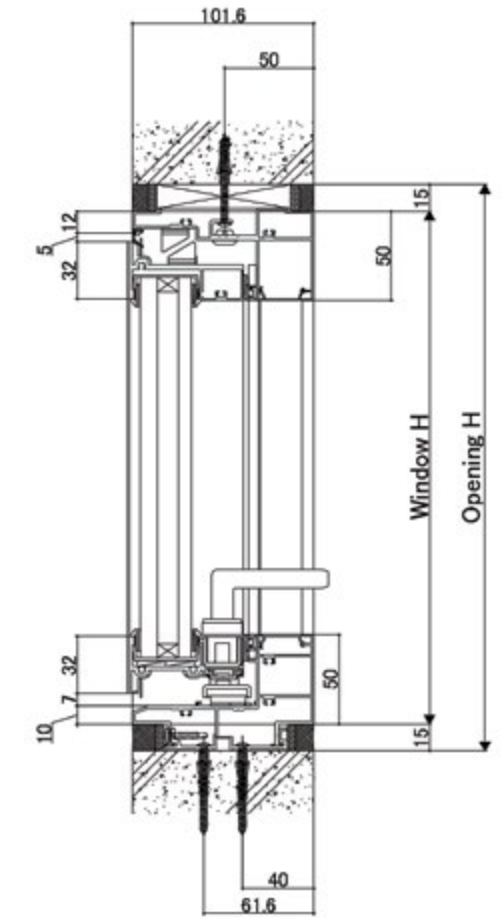

< Vertical section: Awning window >

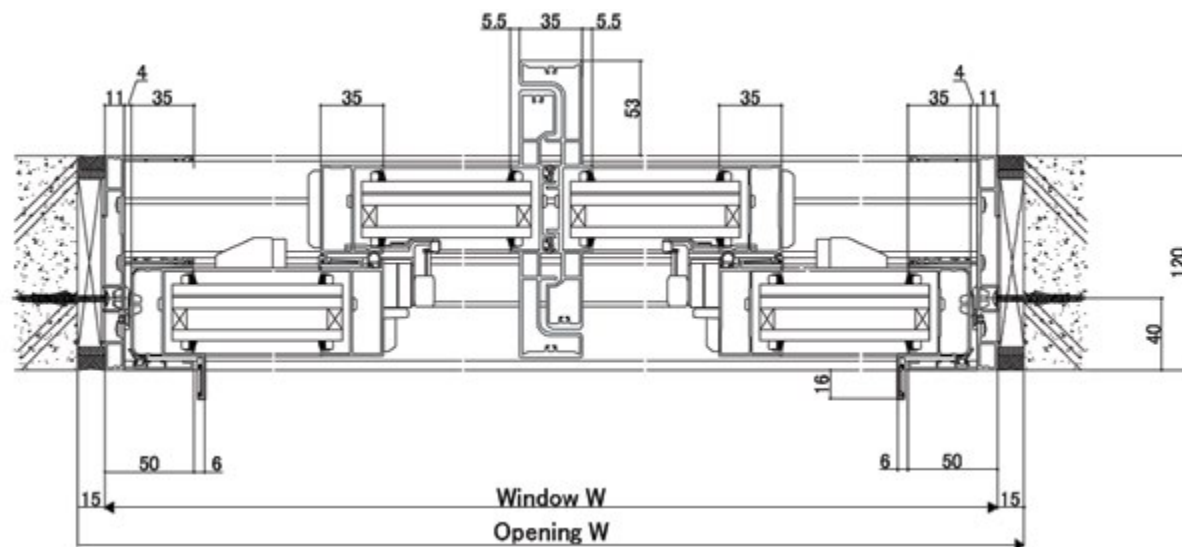

< Horizontal section: 4 panels sliding window >

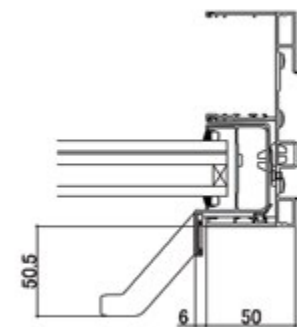

< In case with handle option > (Stile)

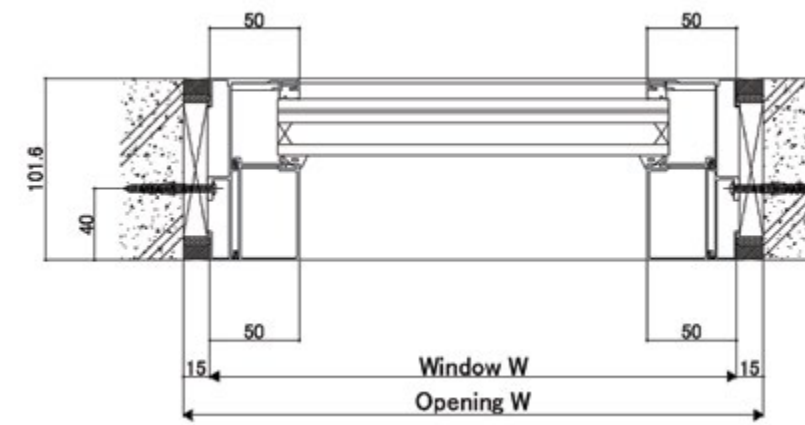

< Horizontal section: Fixed window >

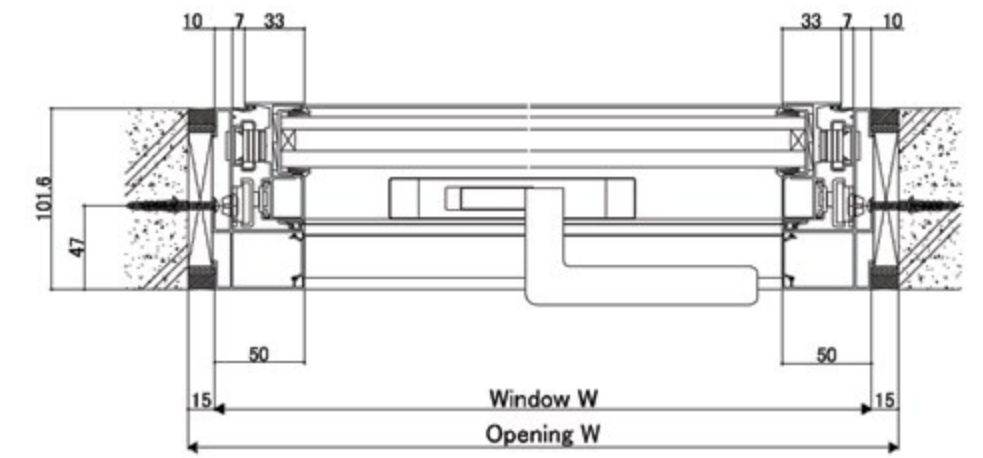

< Horizontal section: Awning window >

< Head detail >

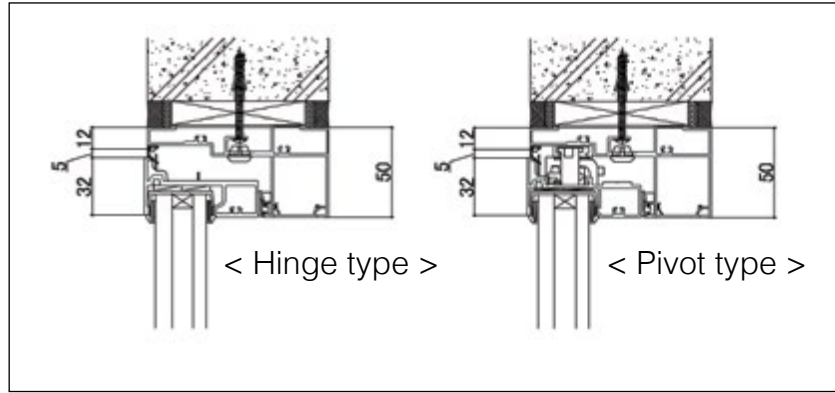

< Sill detail >

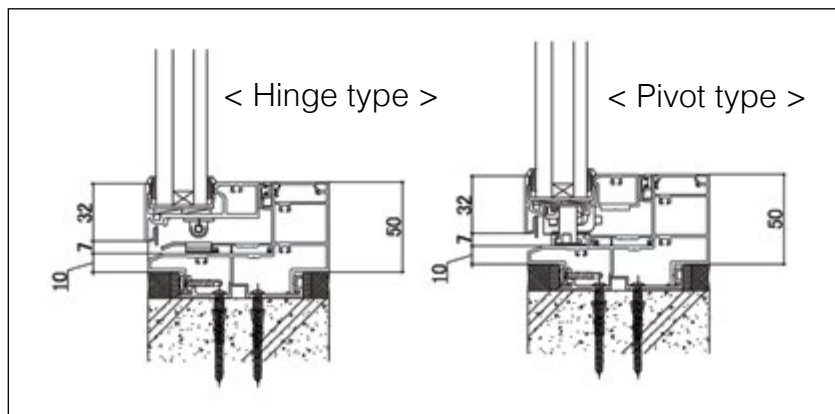

< Jamb detail >

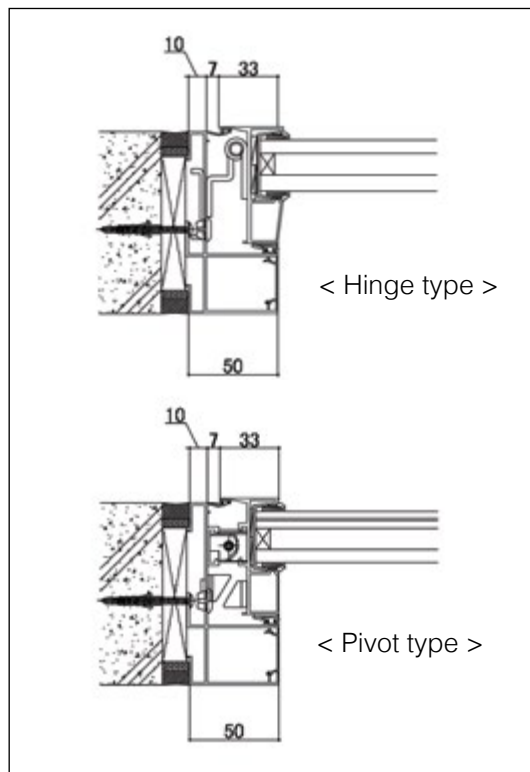

**GRANTS DOOR SERIES**

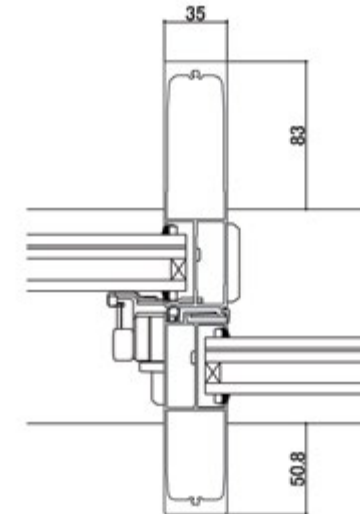

< Meeting stile detail: In case of largest openings >

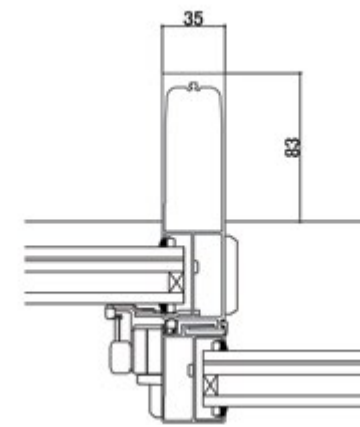

< Meeting stile detail: In case of larger openings >

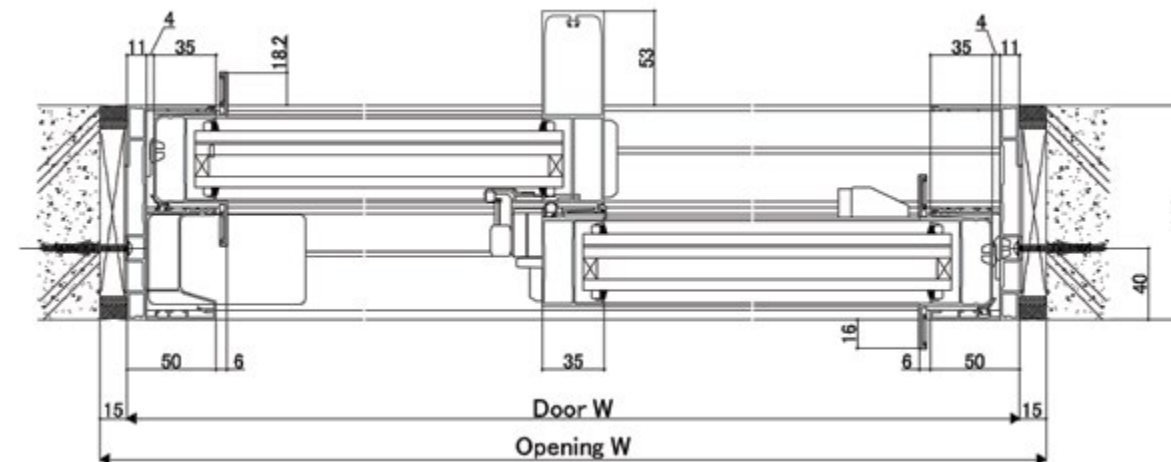

< Horizontal section: 2 panels Sliding door >

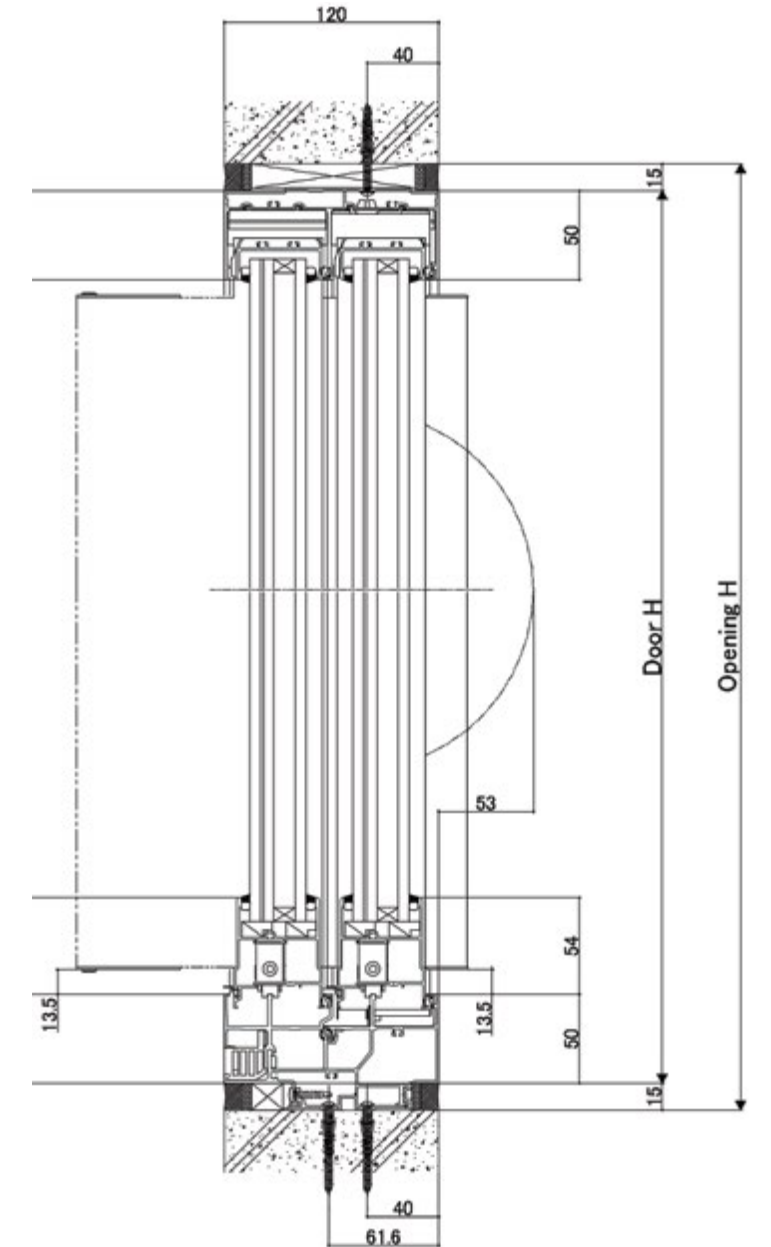

< Vertical section: 2 panels Sliding door >

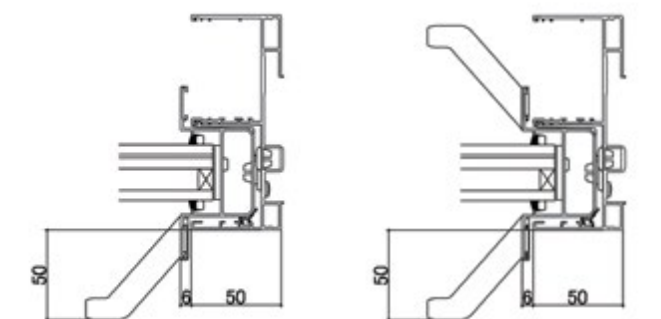

< Inside only >

< Inside & Outside >

< In case with handle option >

< Vertical section: Casement (with friction stay) >

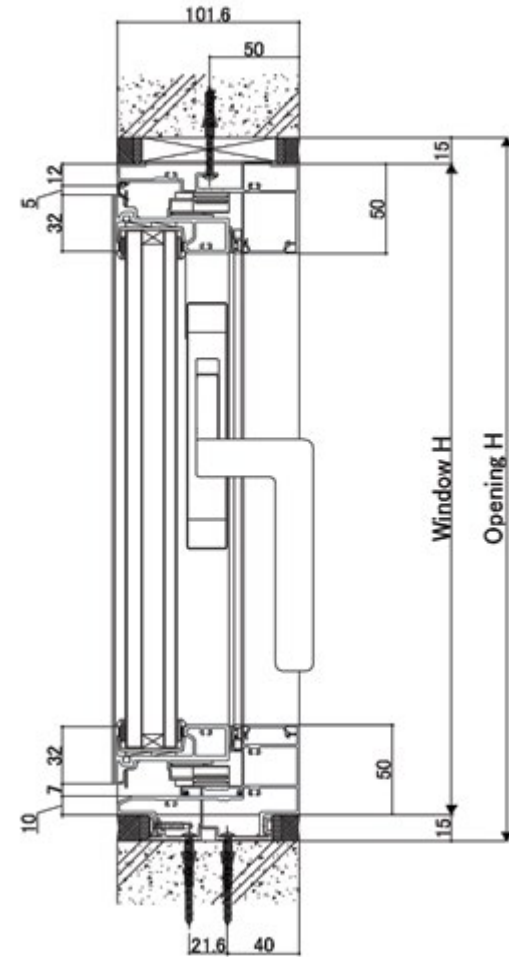

< Horizontal section: Casement (with friction stay) >

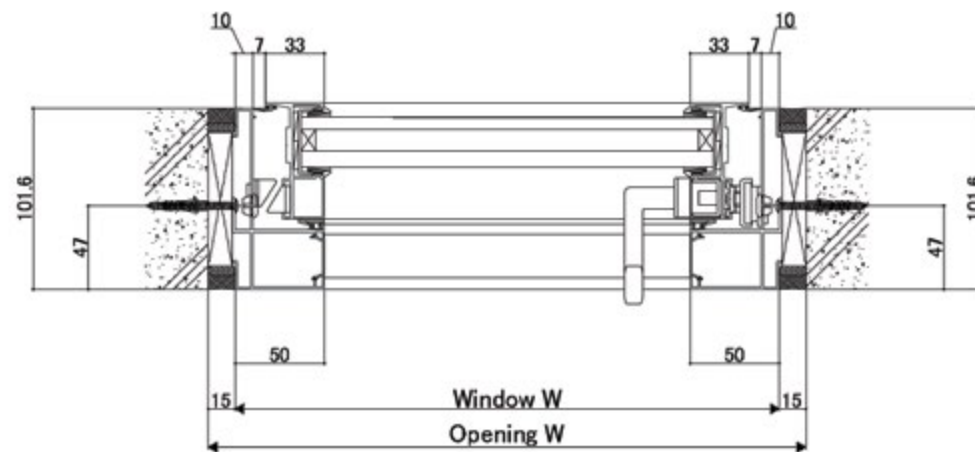



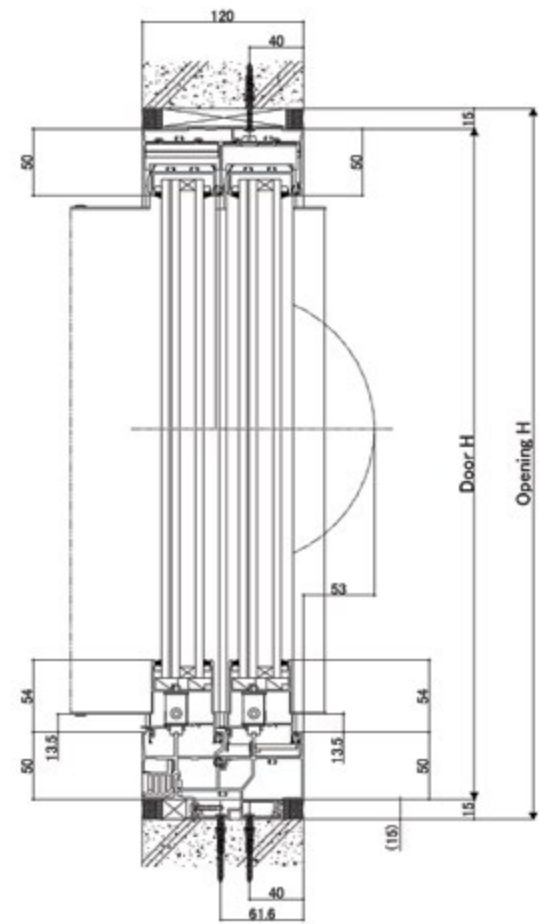

< Vertical section: 4 panels sliding door >

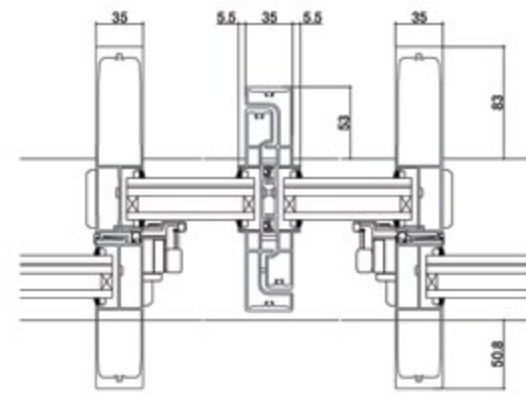

< Stiles detail: In case of largest openings >

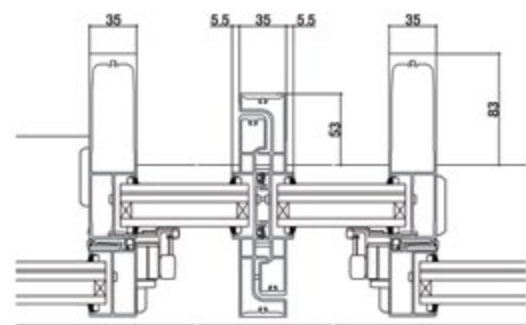

< Stiles detail: In case of larger openings >

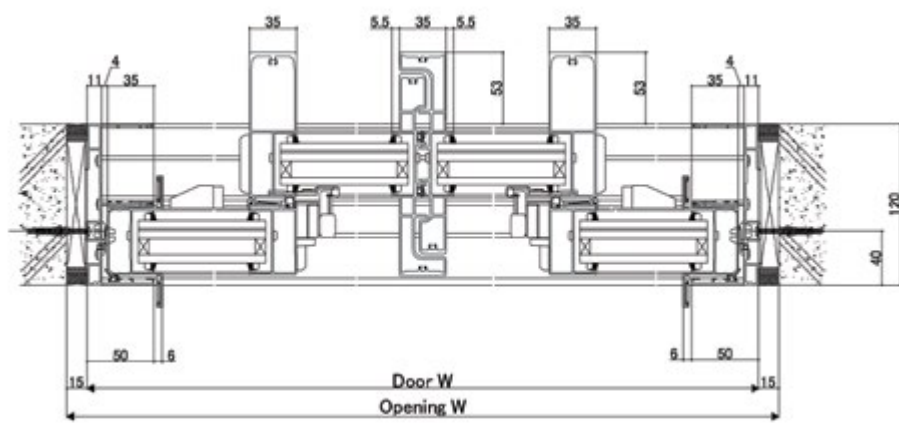

< Horizontal section: 4 panels sliding door >

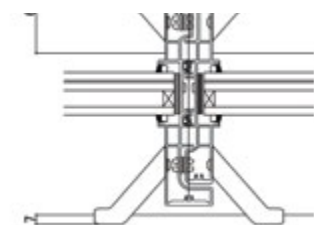

< In case with handle option >

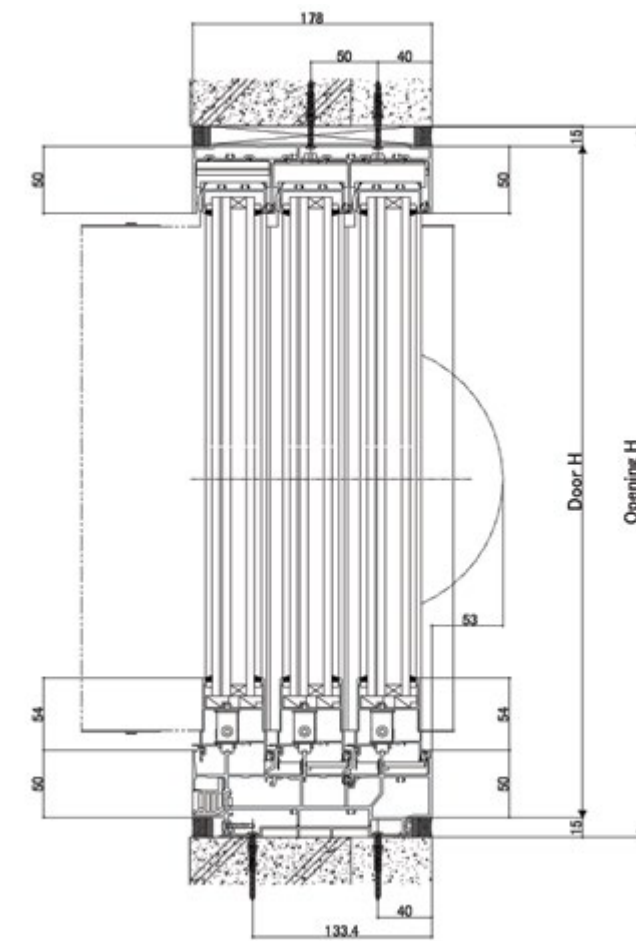

< Vertical section: 3 panels sliding door >

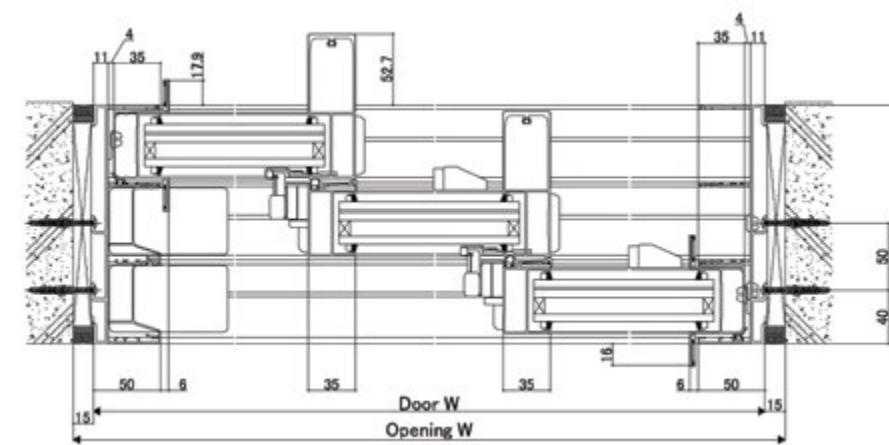

< Horizontal section: 3 panels sliding door >

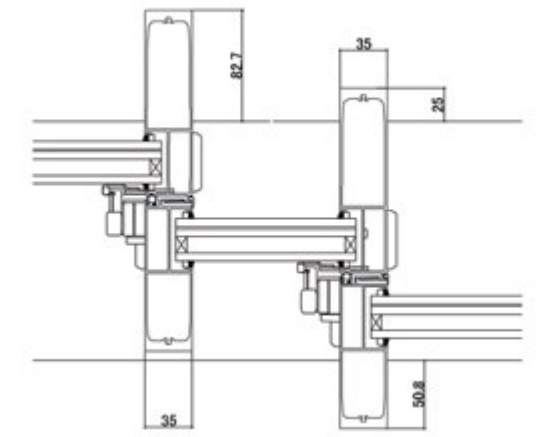

< Stiles detail: In case of largest openings >

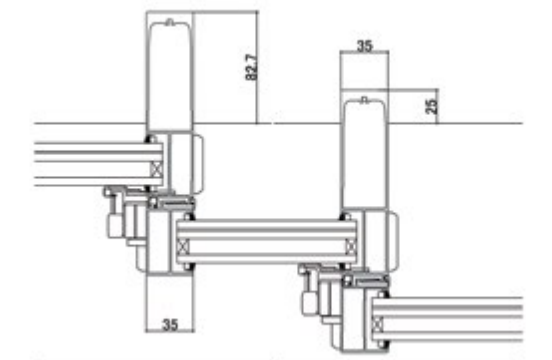

< Stiles detail: In case of largest openings >

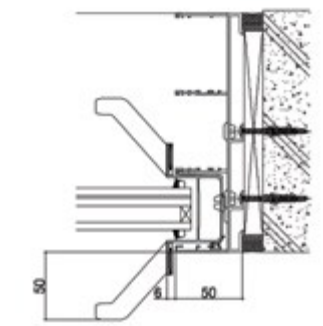

< In case with handle option >

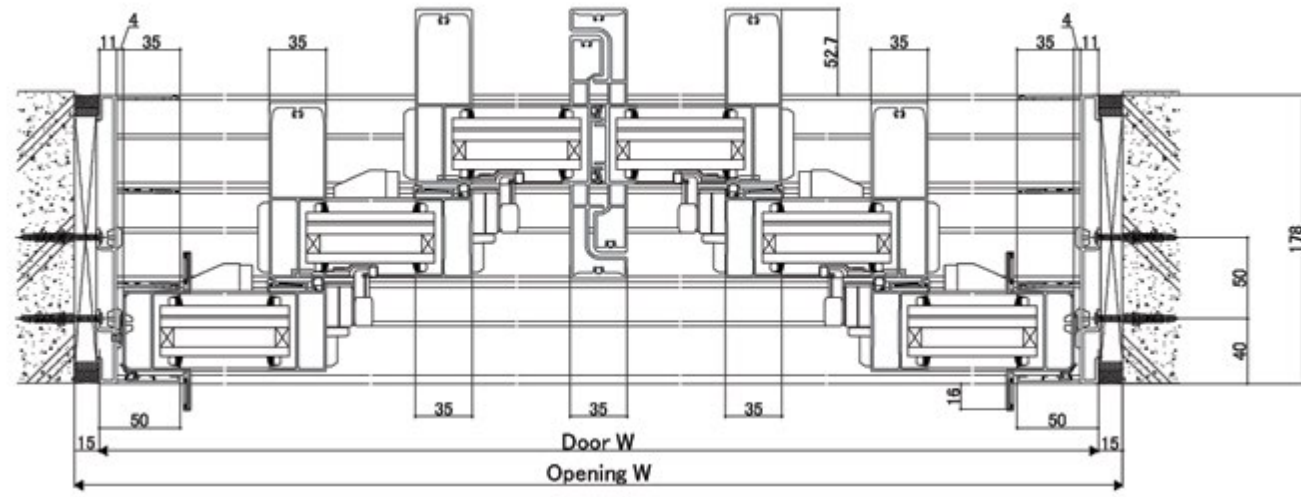

< Horizontal section: 6 panels sliding door >

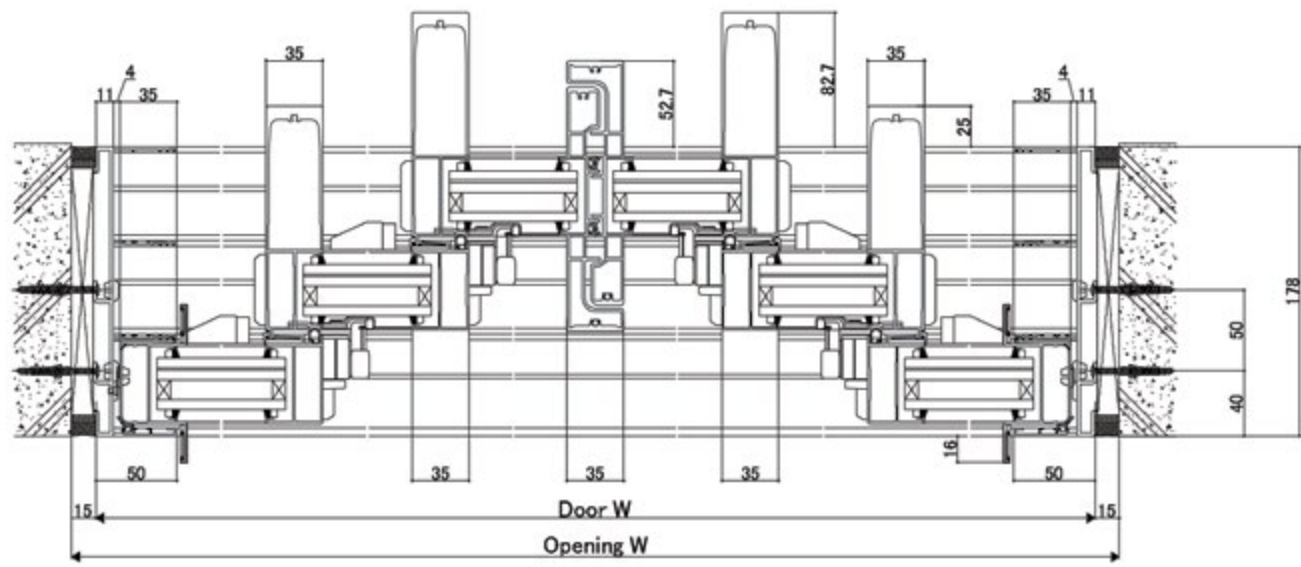

< Horizontal section: 6 panels sliding door (larger) >

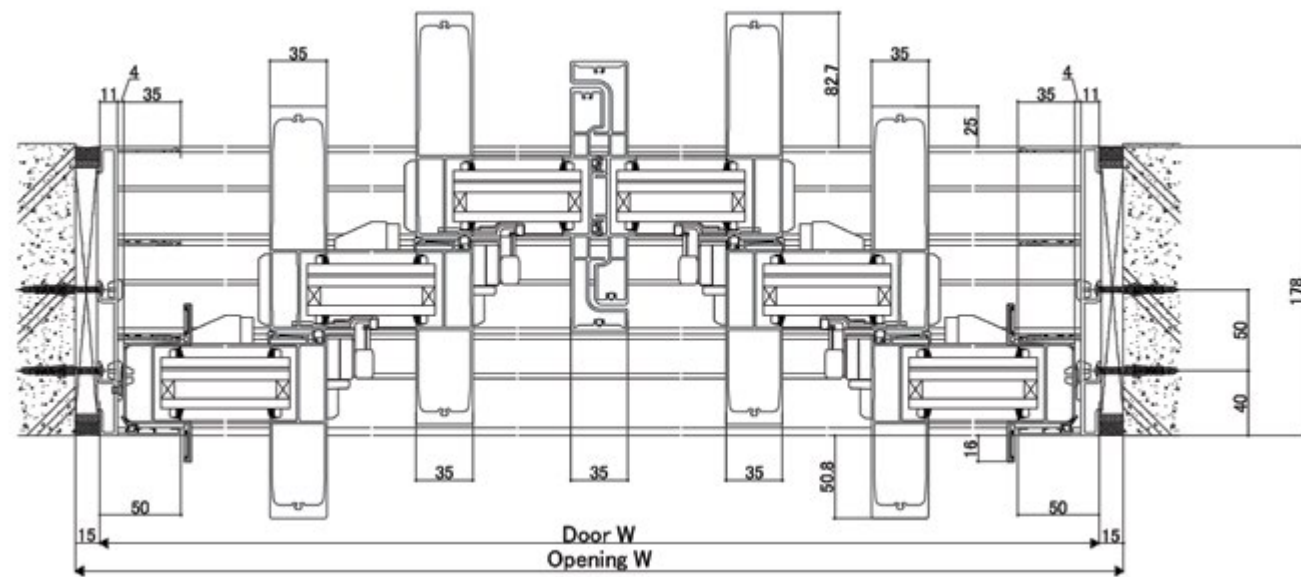

< Horizontal section: 6 panels sliding door (largest) >

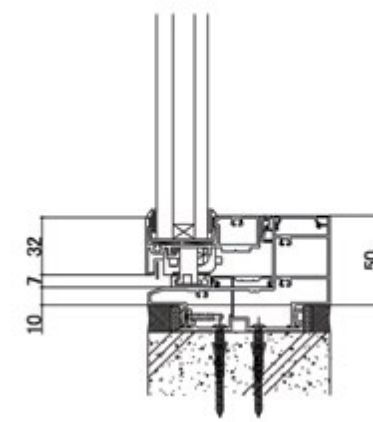

< Sill detail: Pivot hinge >

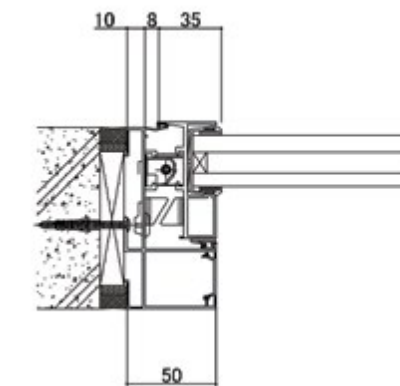

< Jamb detail: Pivot hinge >

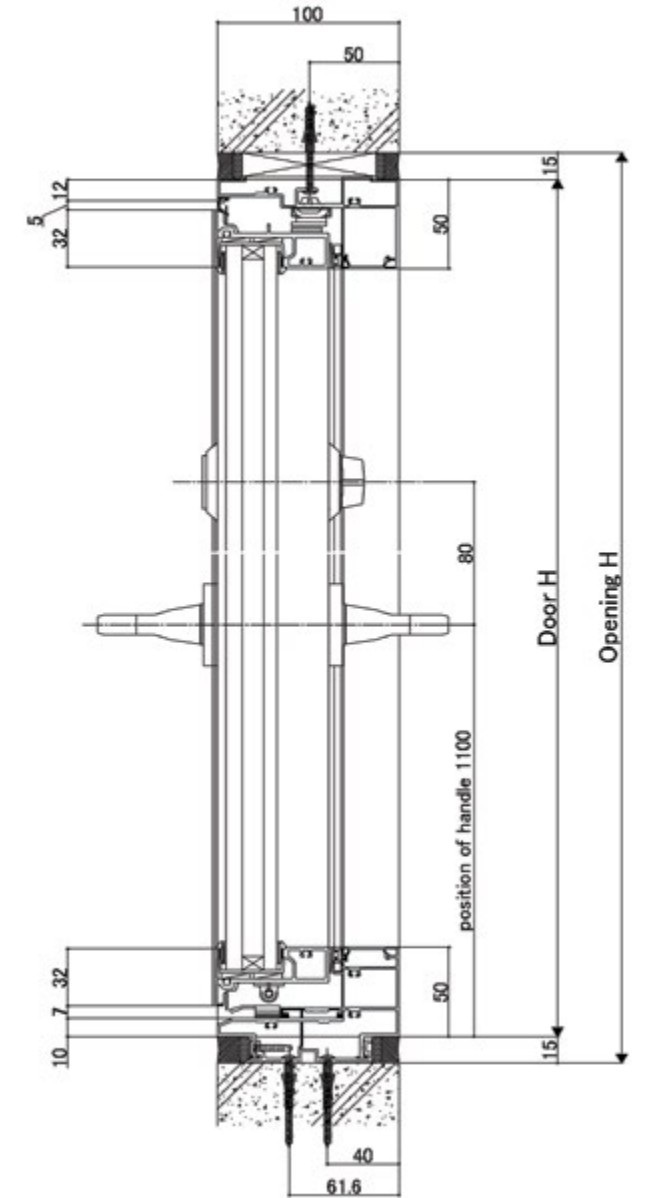

< Vertical section: Single out-swing door >

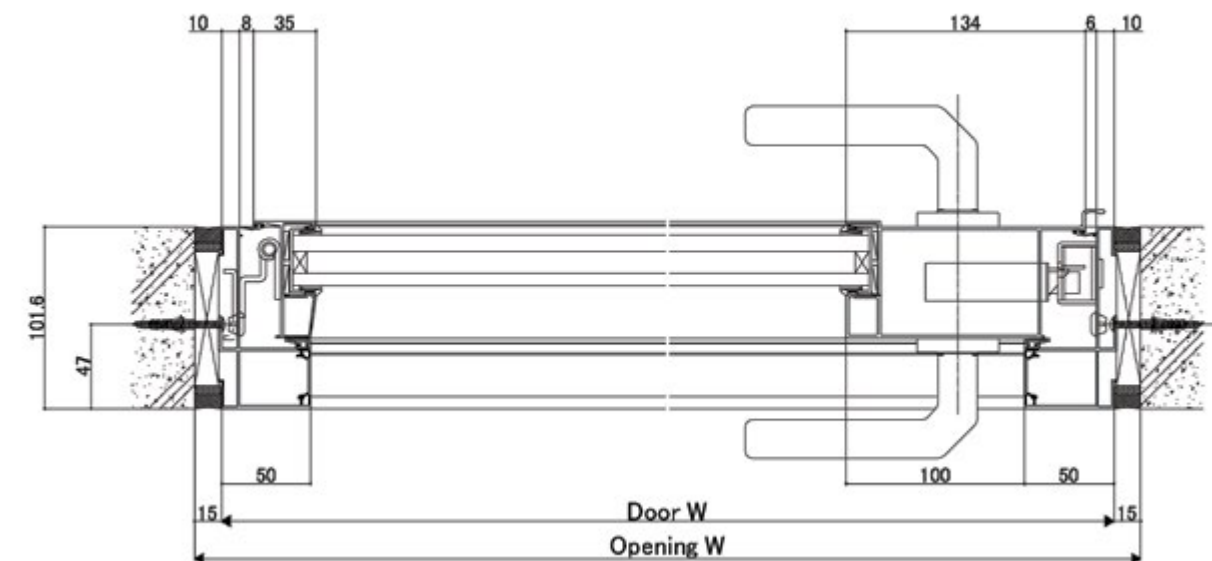

< Horizontal section: Single out-swing door >



GRANTS COMBINATION

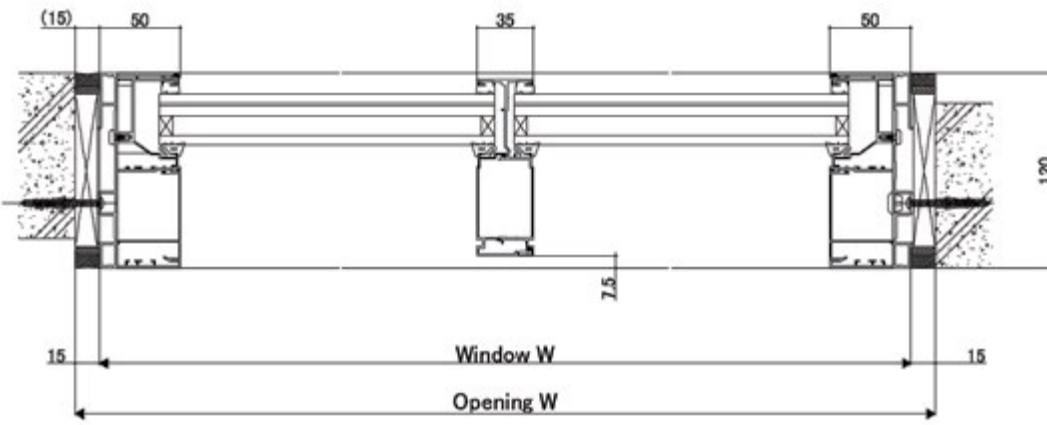
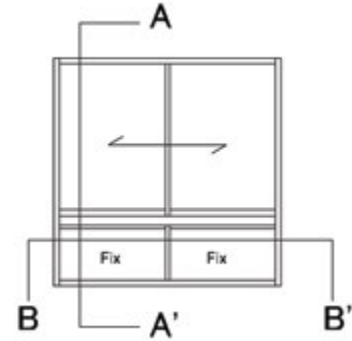

< Horizontal section: Sliding/Fixed B-B' >

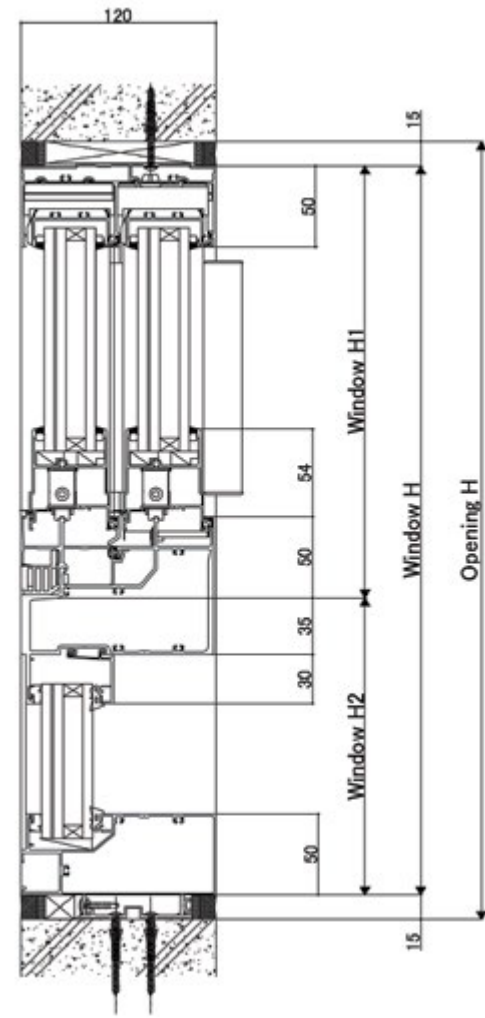

< Vertical section: Sliding/Fixed A-A' >

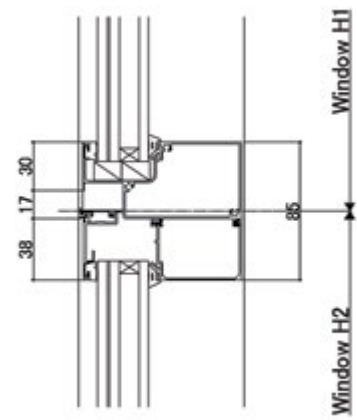

< Vertical: Fixed/Fixed transom >

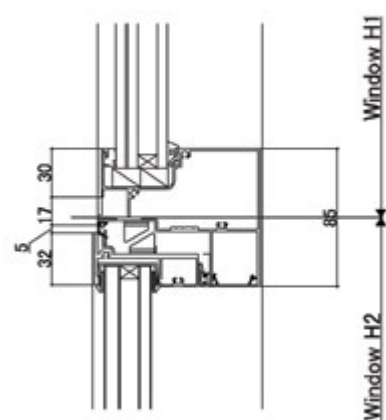

< Vertical: Fixed/Projection transom >

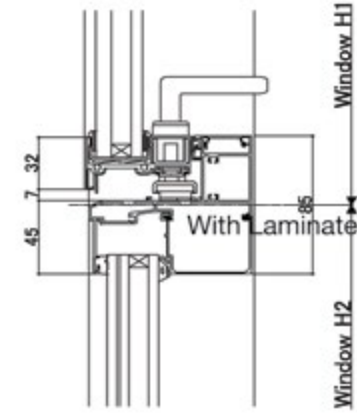

< Vertical: Projection/Fixed transom >

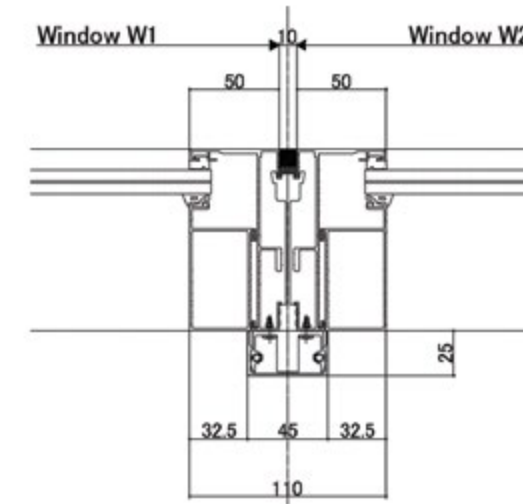

< Mullion type A >

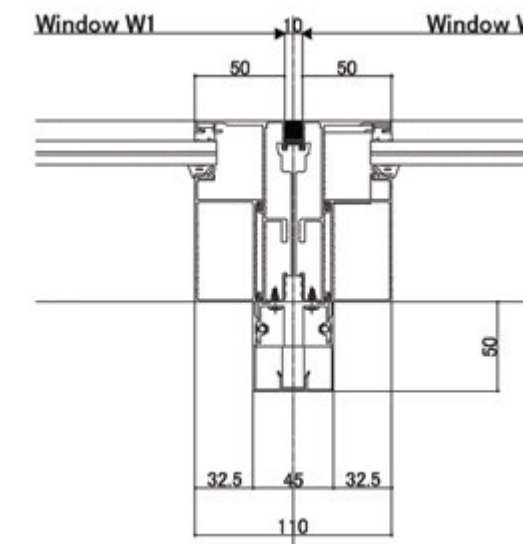

< Mullion type B >

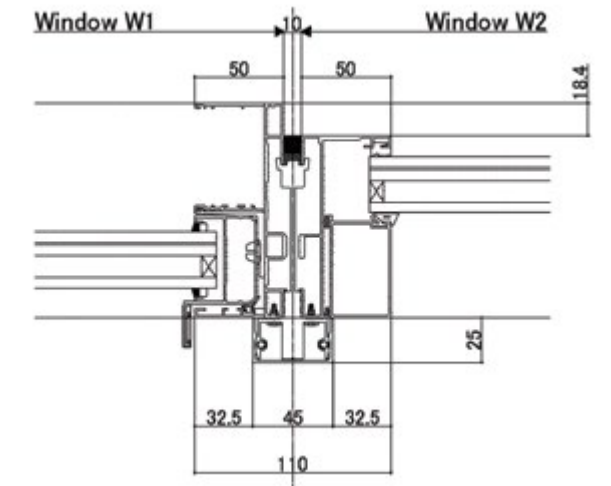

< Mullion type A with sliding window >

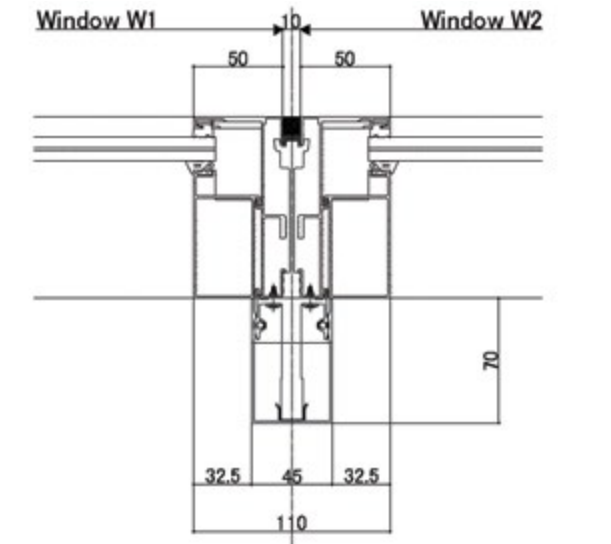

< Mullion type C >

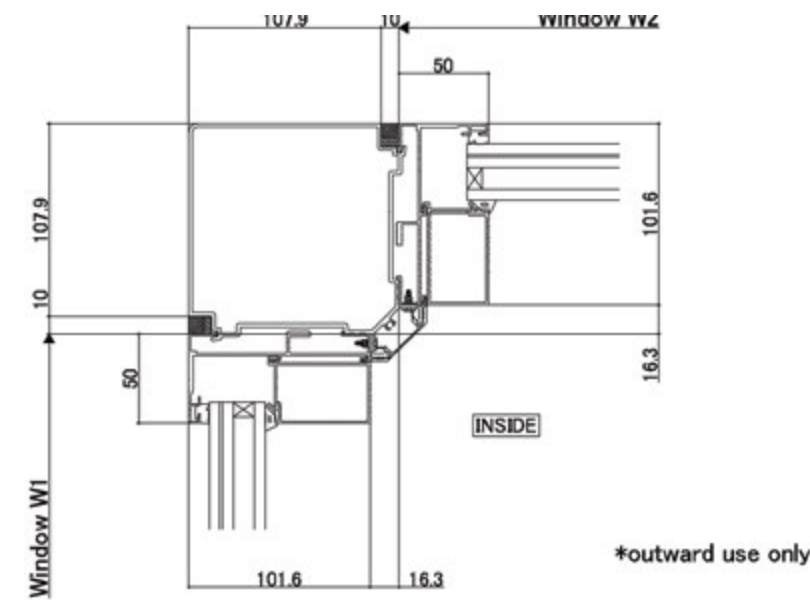

< Corner mullion >

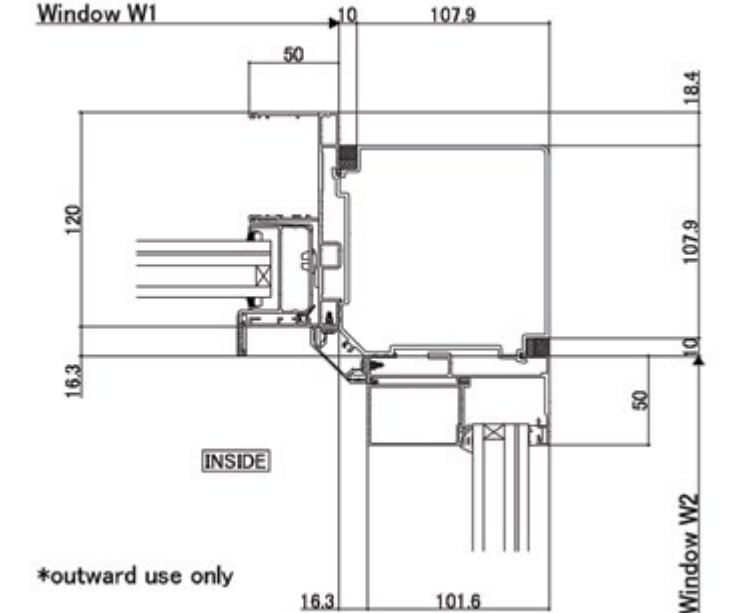

< Corner mullion with sliding window >

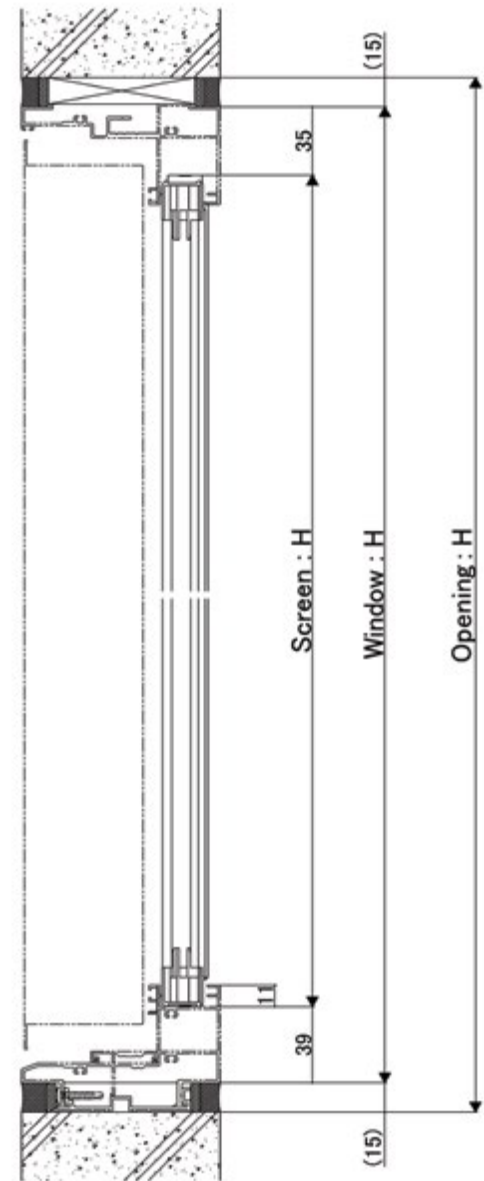

< Vertical section: Awning & Casement >

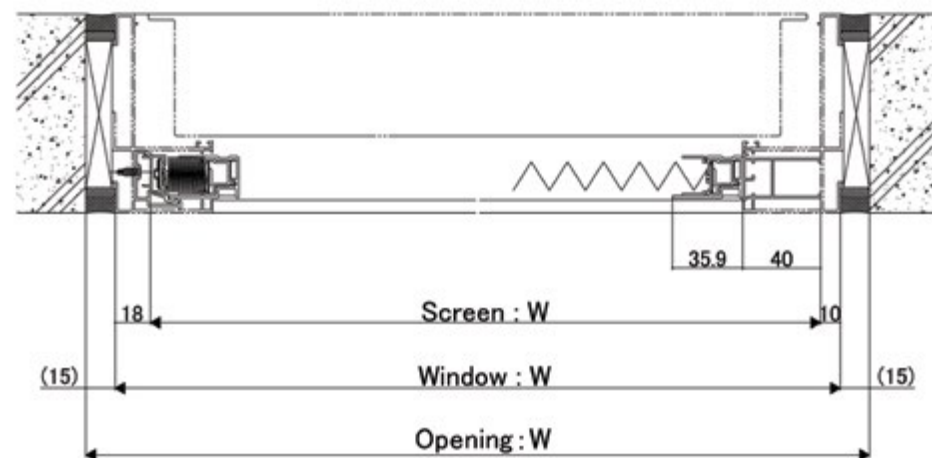

< Horizontal section: Awning & Casement >

## GRANTS SLIDING DOOR FLAT RAIL

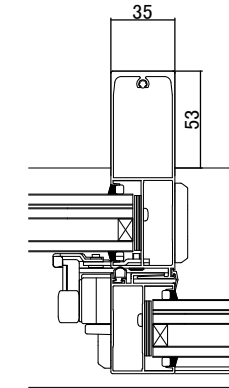

< In case of smaller openings >

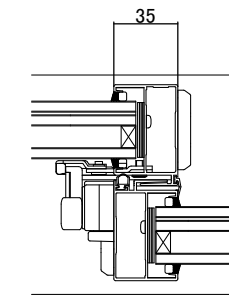

< In case of smallest openings >

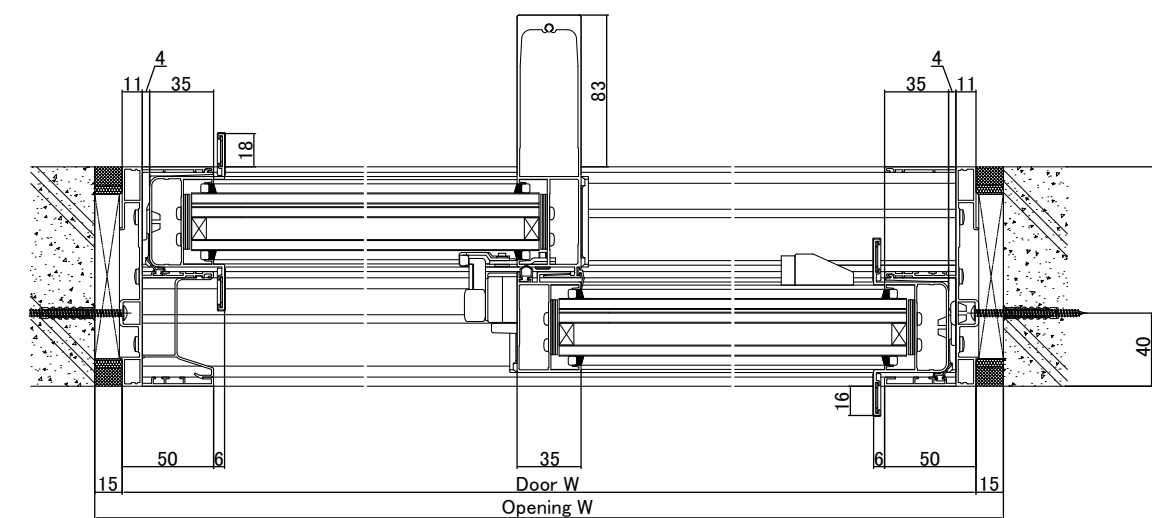

< Horizontal section : 2 panels Sliding door >

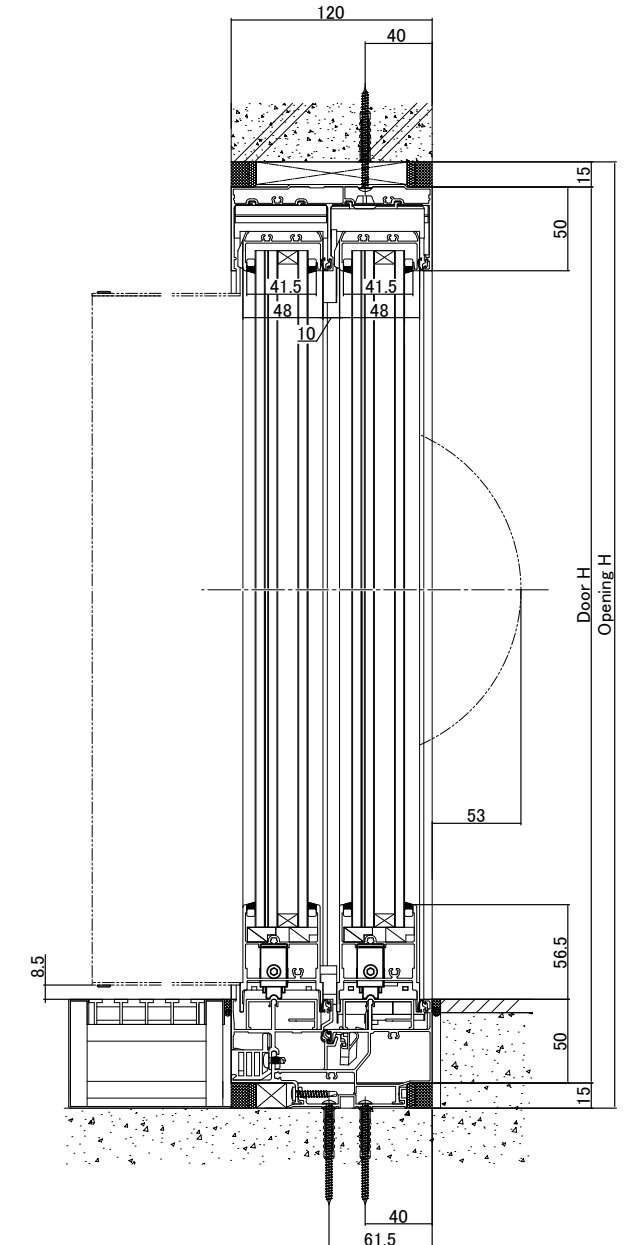

< Vertical section : 2 panels Sliding door >

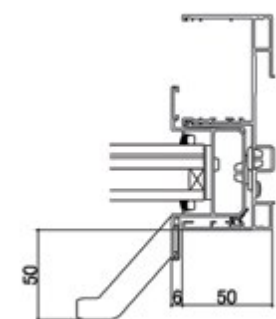

< Inside only >

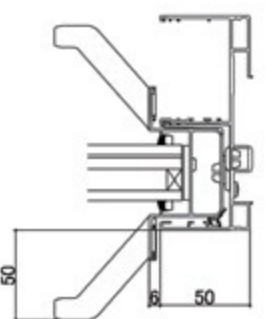

< Inside & Outside >

< In case with handle option >



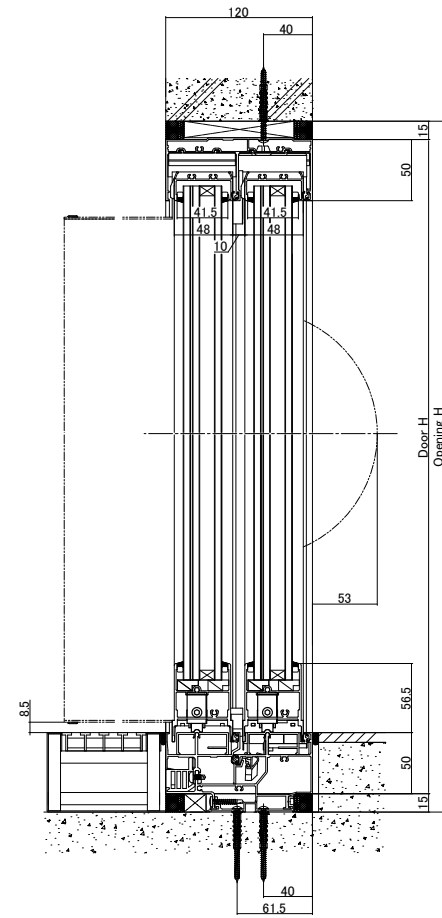

< Vertical section : 4 panels Sliding door >

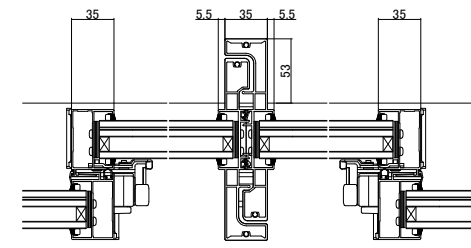

< In case of smallest openings >

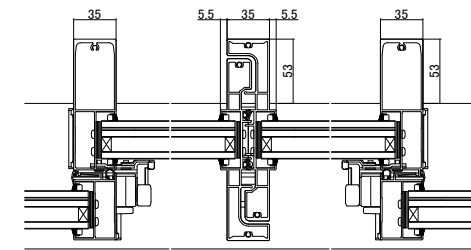

< In case of smaller openings >

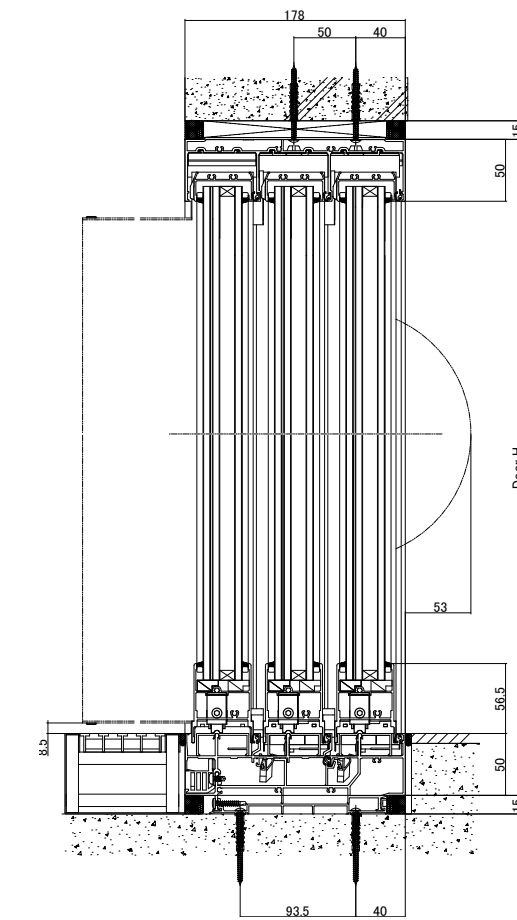

< Vertical section : 3 panels Sliding door >

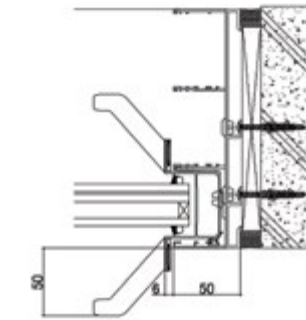

< In case with handle option >



< Horizontal section : 3 panels Sliding door >

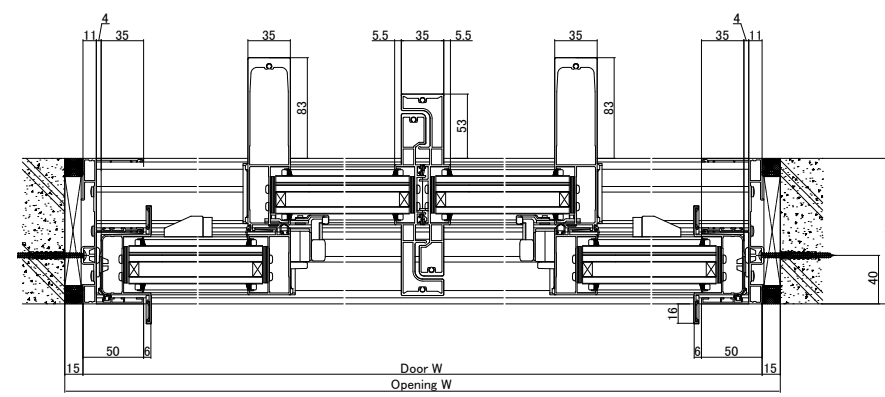

< Horizontal section : 4 panels Sliding door >

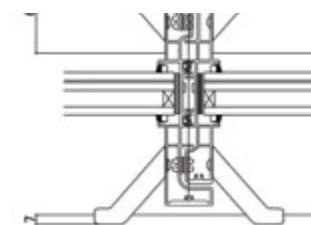

< In case with handle option >

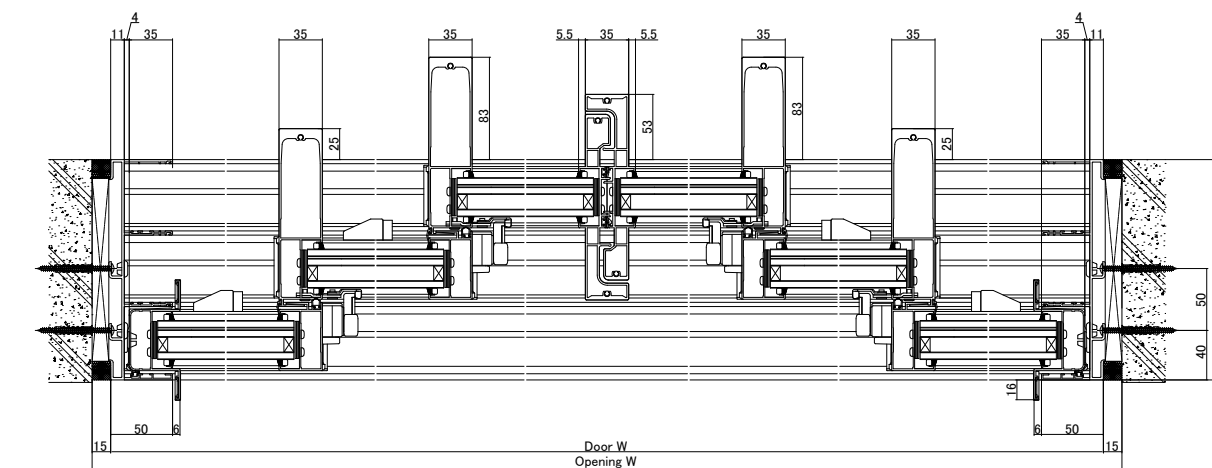

< Horizontal section : 6 panels Sliding door >

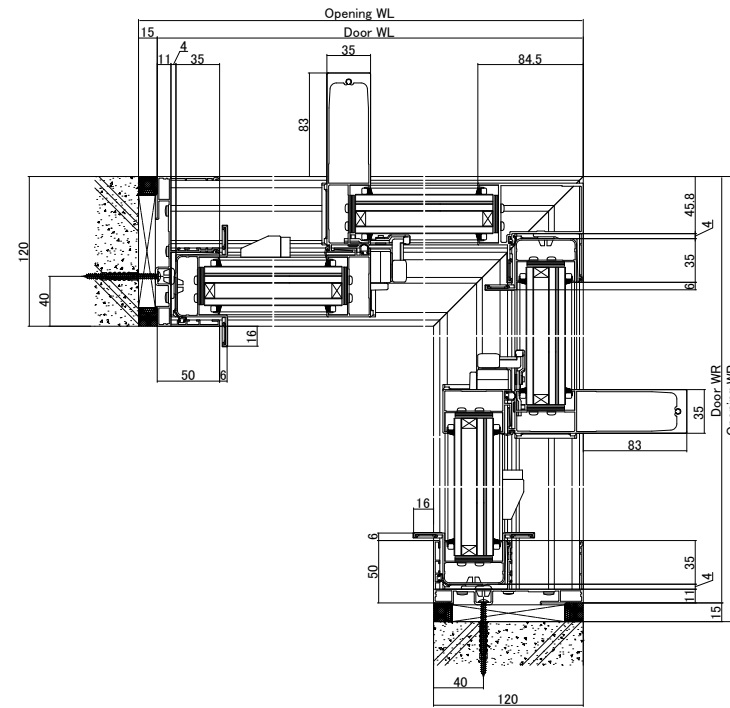

< Horizontal section : 2+2 panels Corner Sliding door >

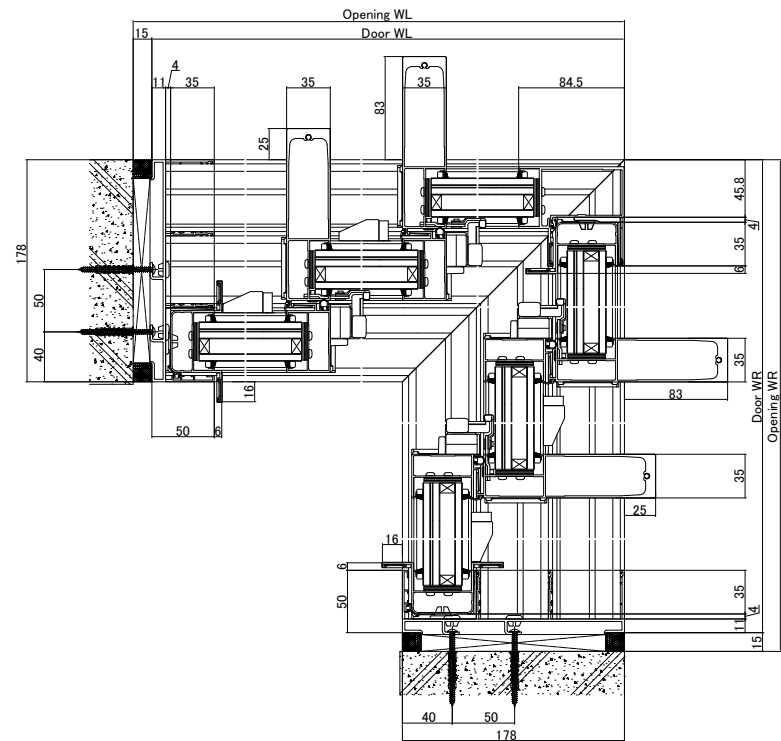

< Horizontal section : 3+3 panels Corner Sliding door >

## ATIS PLUS WINDOW SERIES

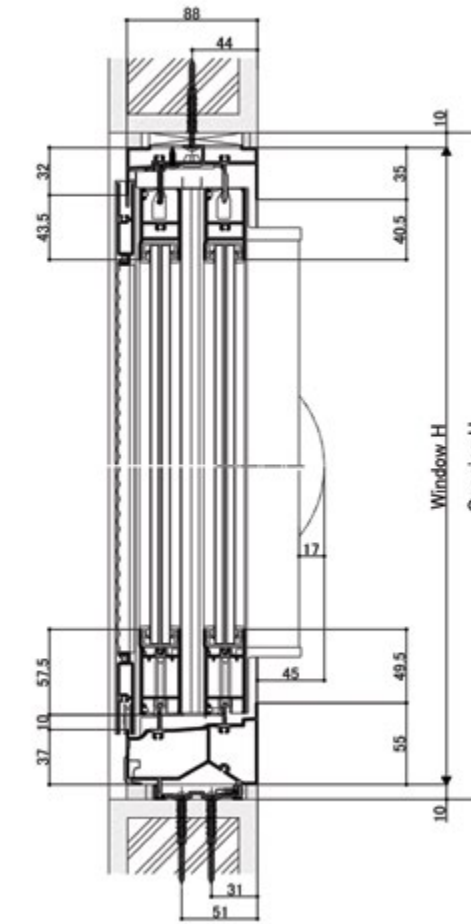

< Vertical section: 2 and 4 panels sliding window >

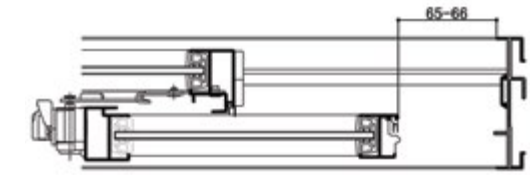

< Options (limit arm) Jamb detail >

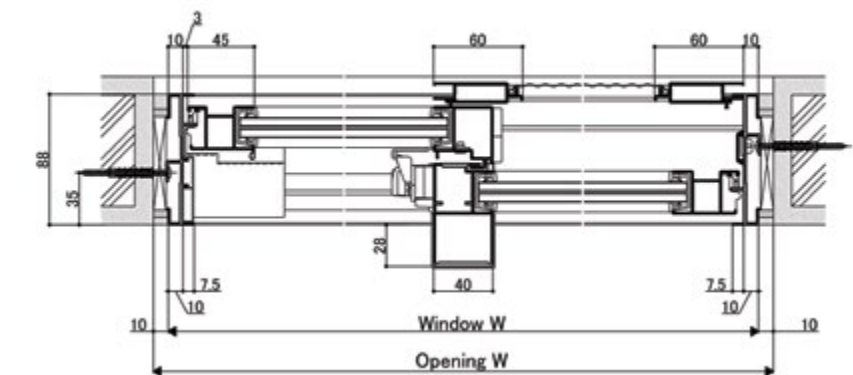

< Horizontal section: 2 panels sliding window >

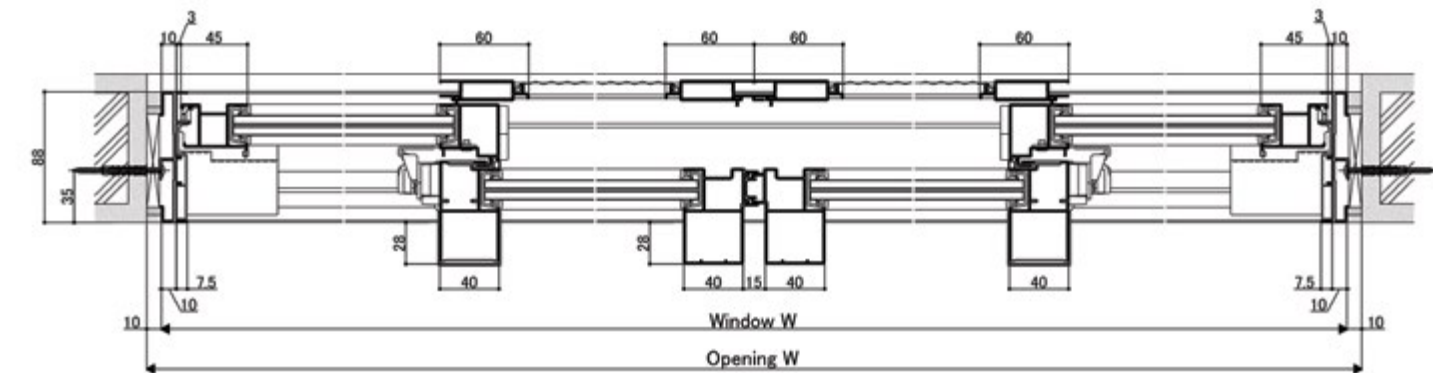

< Horizontal section: 4 panels sliding window >



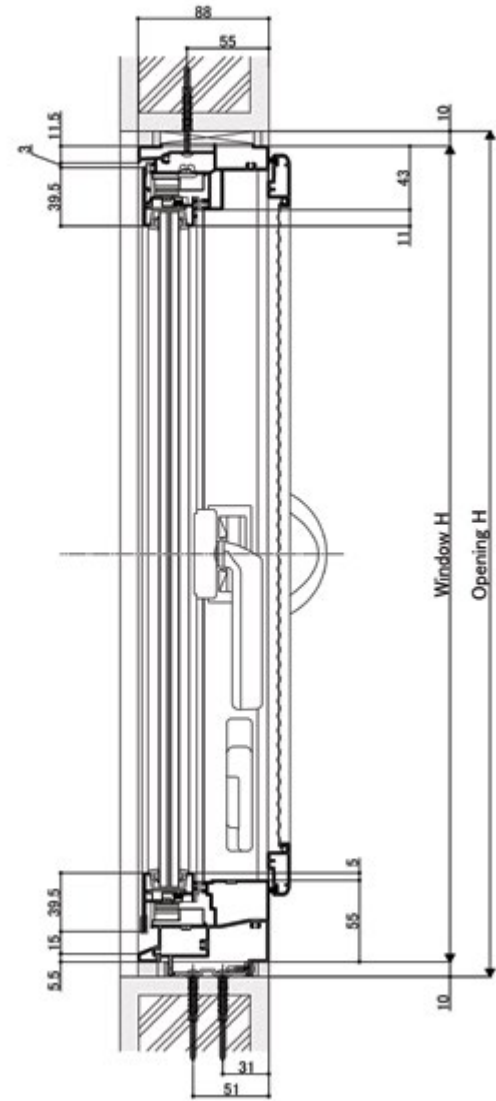

< Vertical section: Casement window (Multi-lock) with screen >

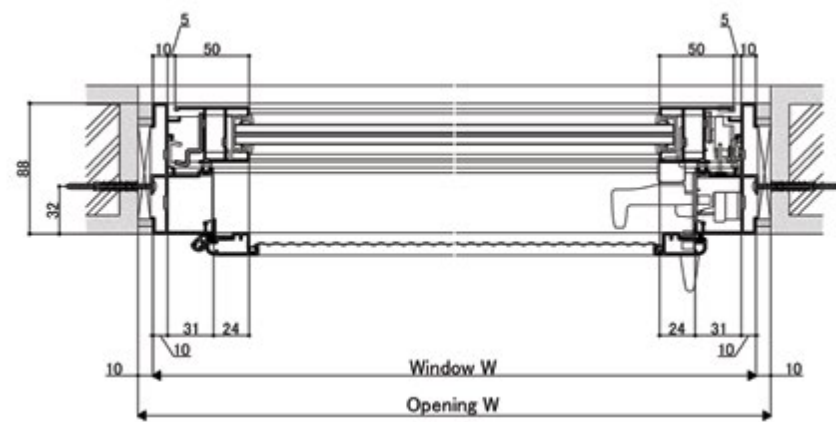

< Horizontal section: Casement with screen >

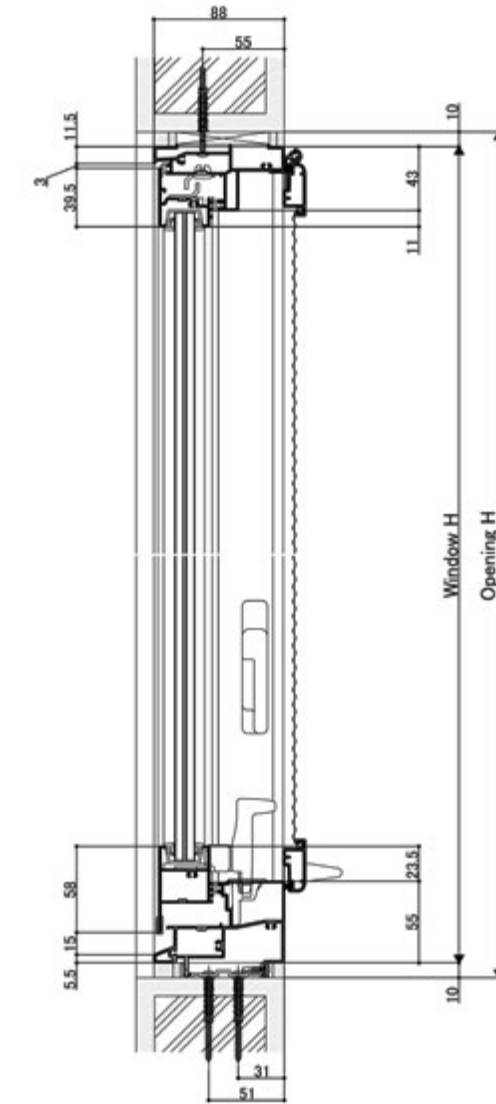

< Vertical section: Awning window (Multi-lock) with screen >

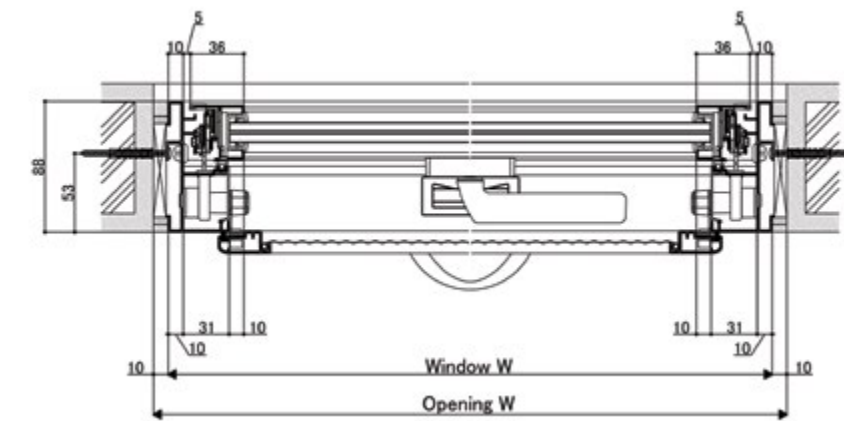

< Horizontal section: Awning with screen >

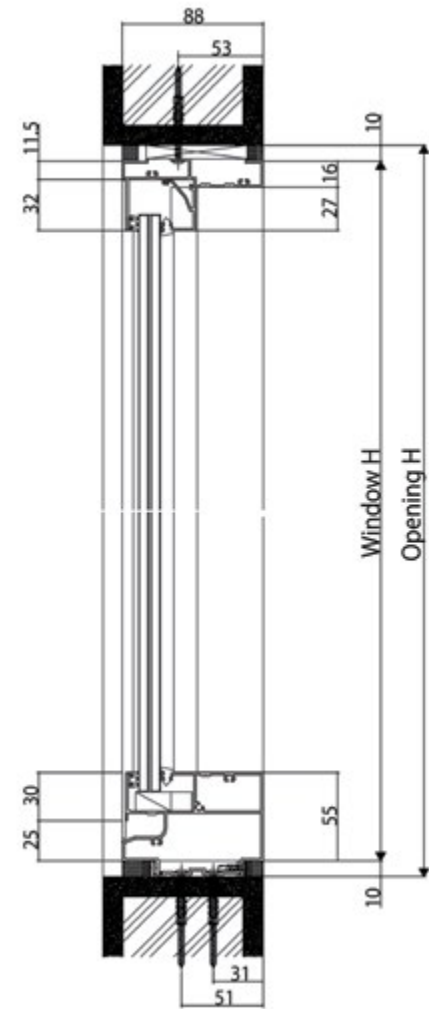

< Vertical section: Single fixed window >

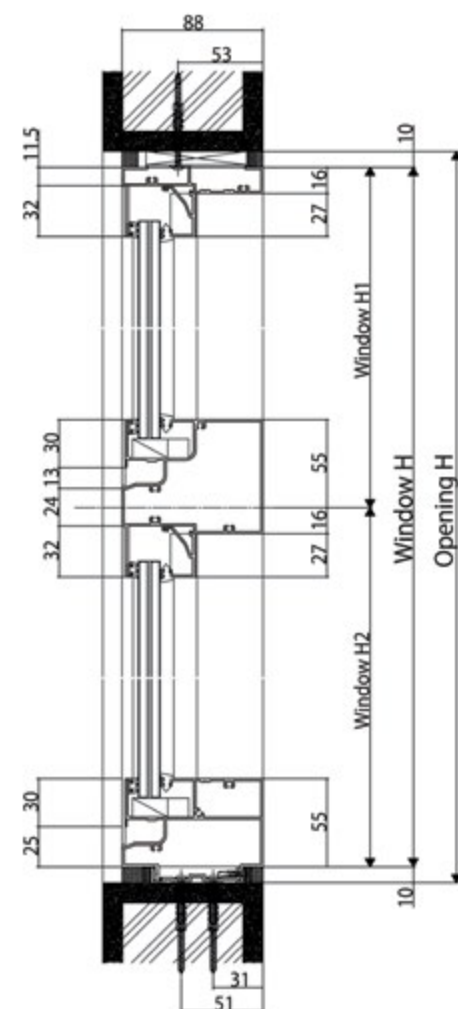

< Vertical section: Fixed window with transom >

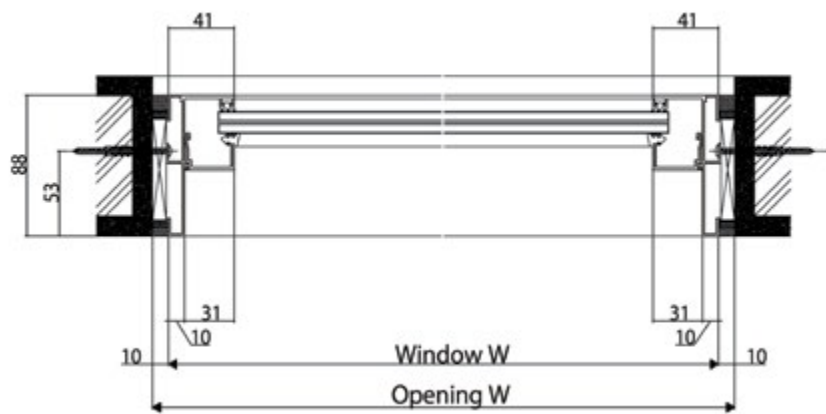

< Horizontal section: Single fixed window >

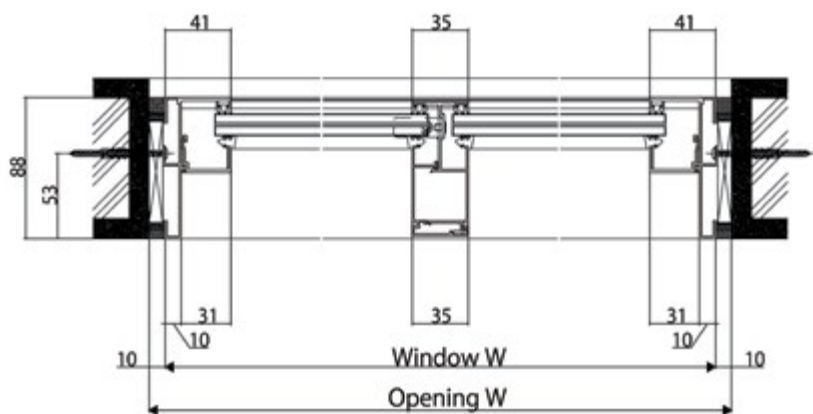

< Horizontal section: Fixed window with mullion >

## ATIS PLUS DOOR SERIES

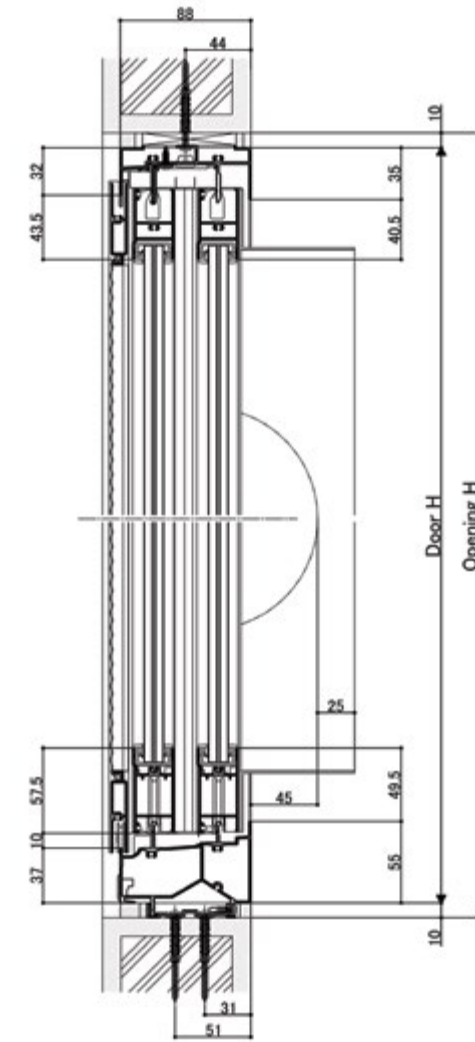

< Vertical section: 2 and 4 panels sliding door >

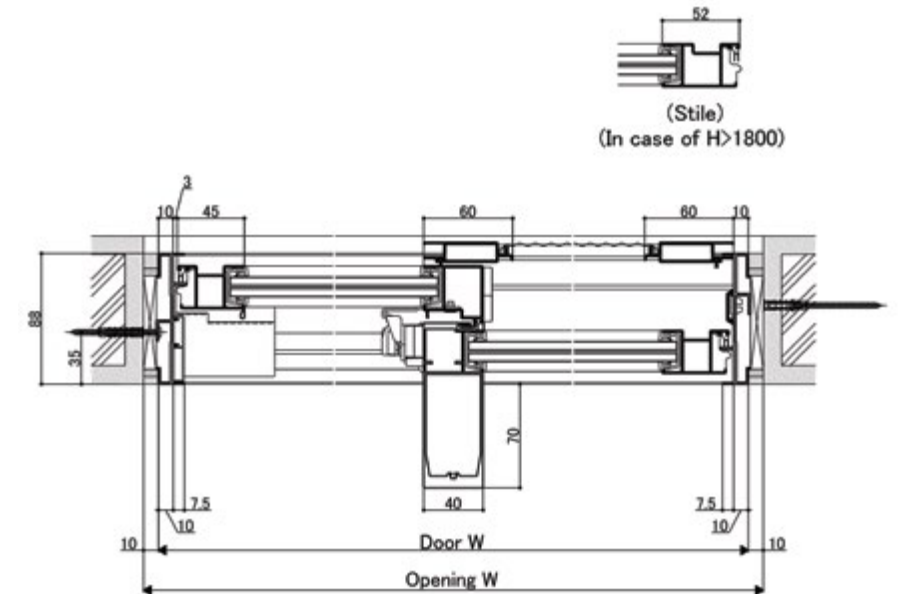

< Horizontal section: 2 panels sliding door >

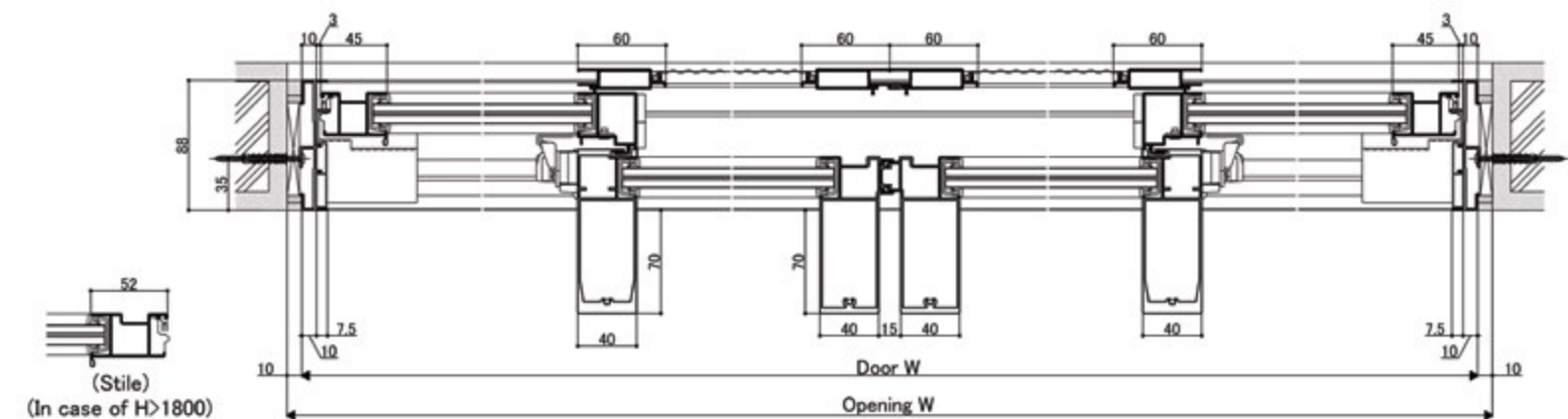

< Horizontal section: 4 panels sliding door >



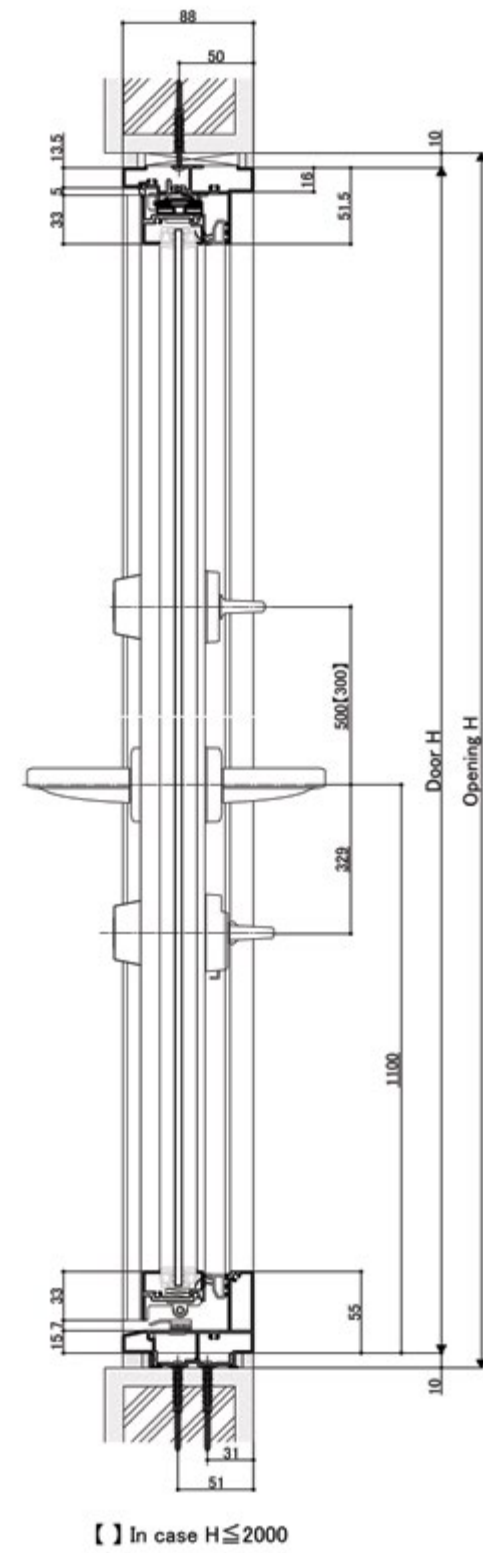

< Vertical section: Single Out-swing door >

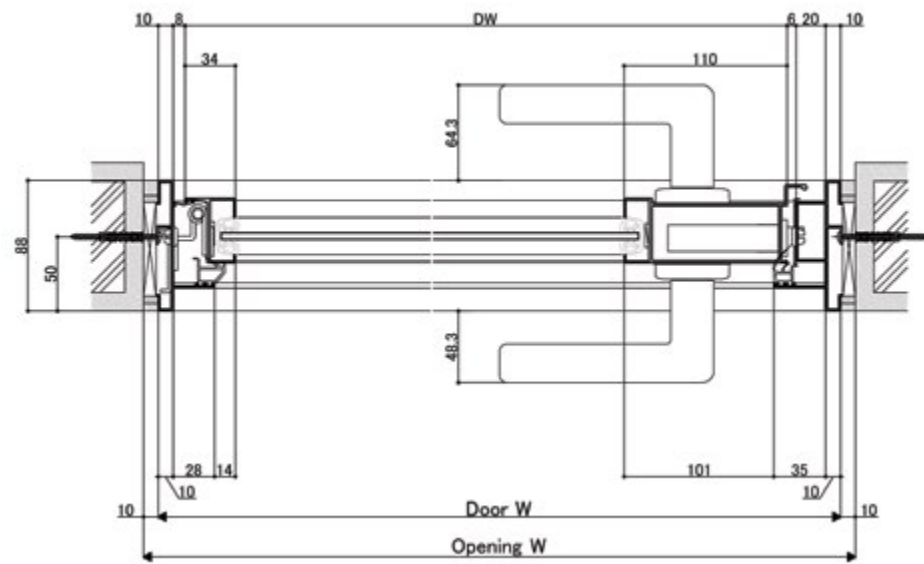

< Horizontal section: Single Out-swing door >

## ATIS PLUS COMBINATION

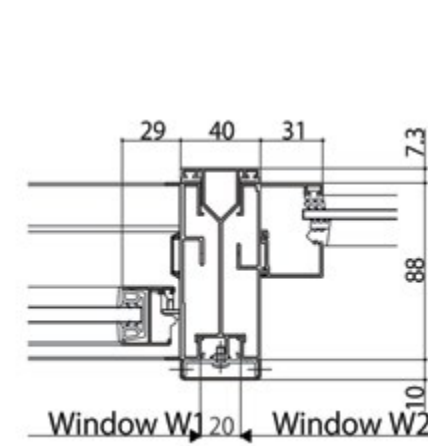

Mullion 180 A Type

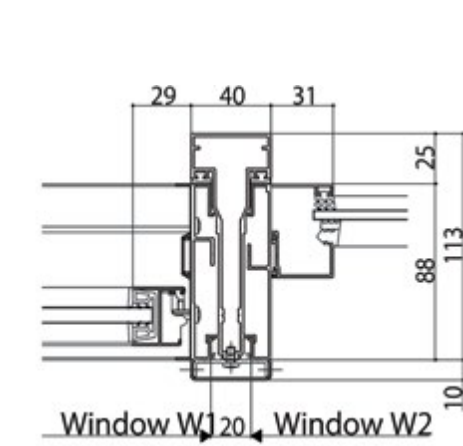

Mullion 180 B Type

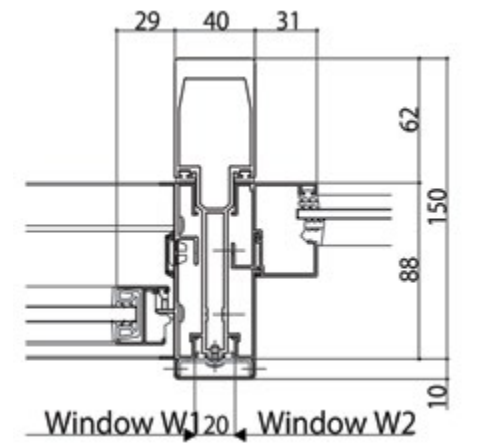

Mullion 180 C Type

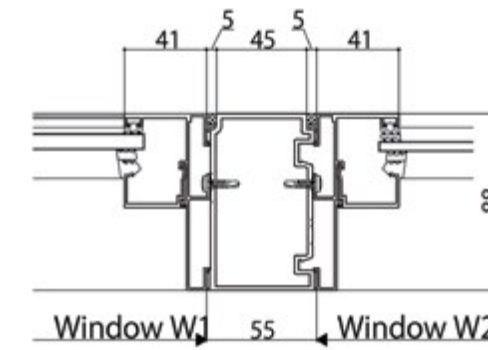

Reinforcement Mullion 180

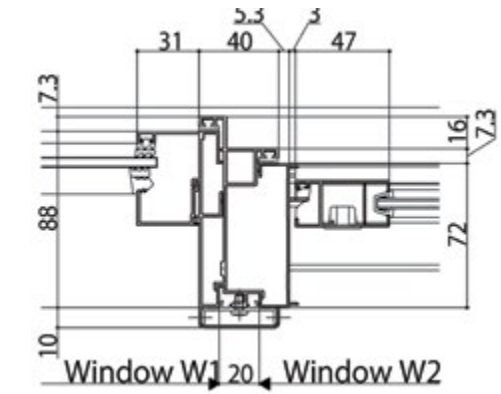

< Horizontal section: Mullion 180 for WE combination >

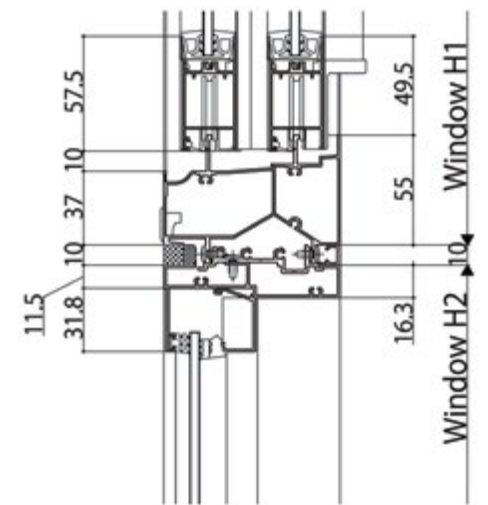

Transom A (88 mm)

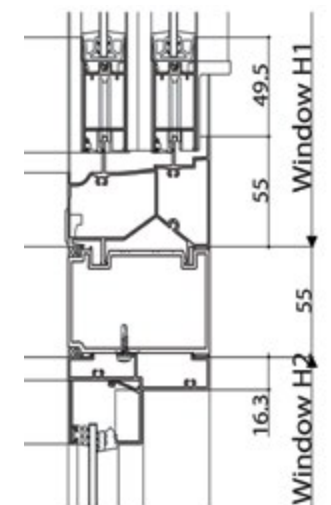

Reinforcement Transom

**WE PLUS WINDOW SERIES**

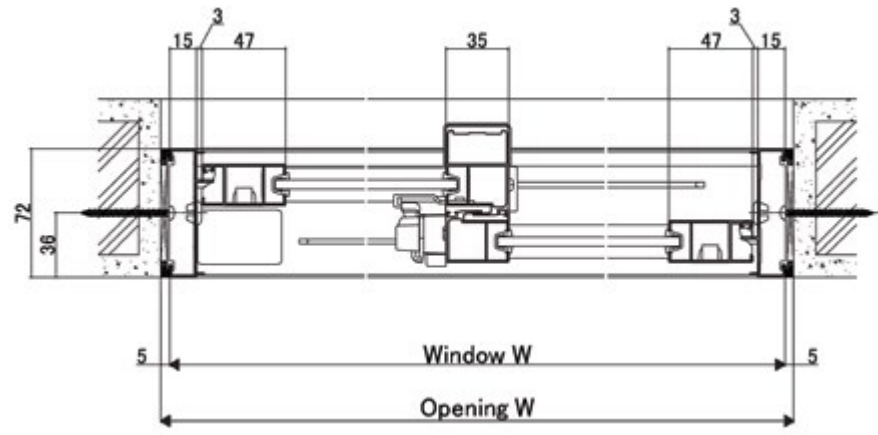

< Horizontal section: Fixed window with mullion >

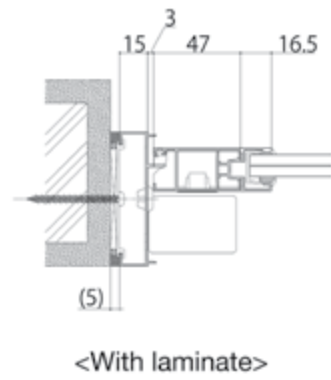

<With laminate>

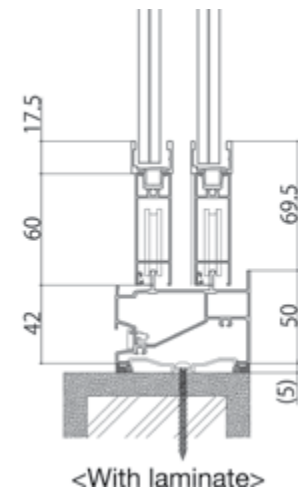

<With laminate>

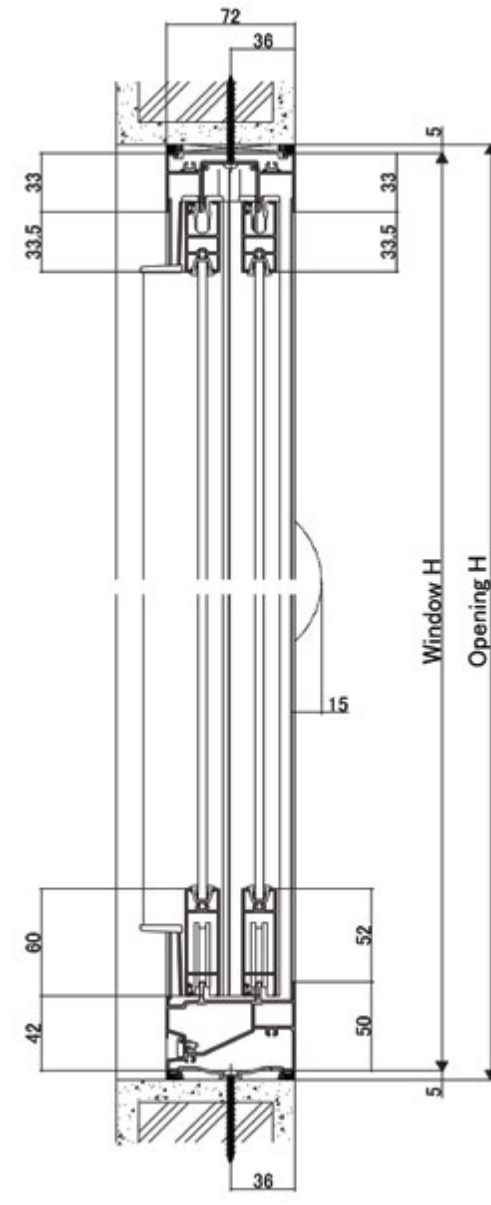

< Vertical section: 2 and 4 panels sliding window >

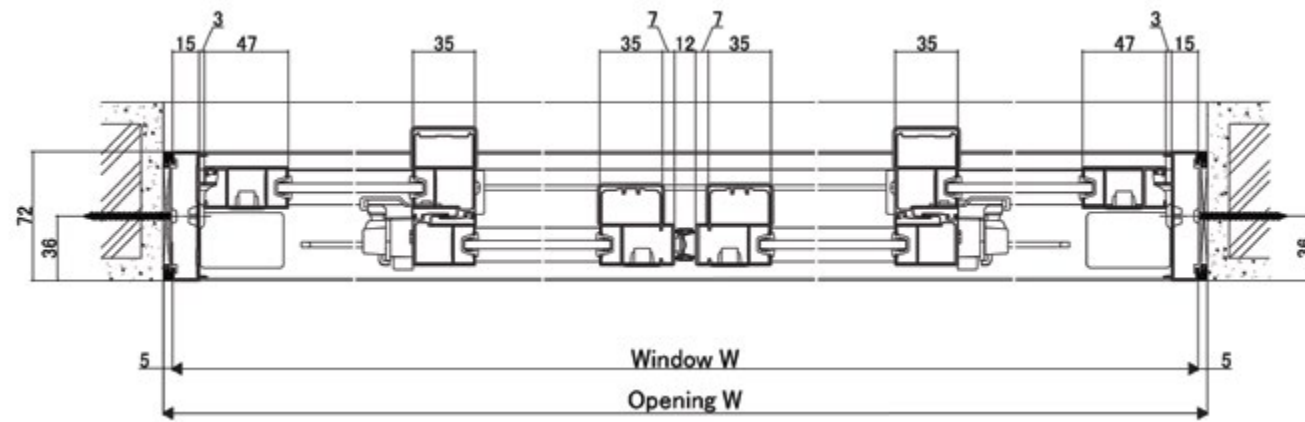

< Horizontal section: 4 panels sliding window >

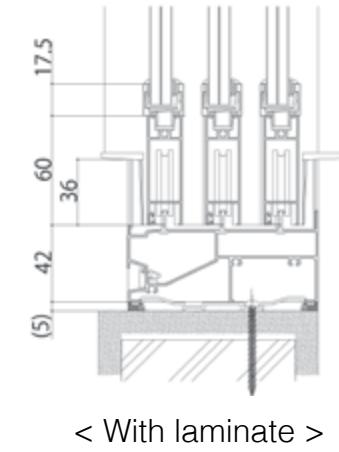

< With laminate >

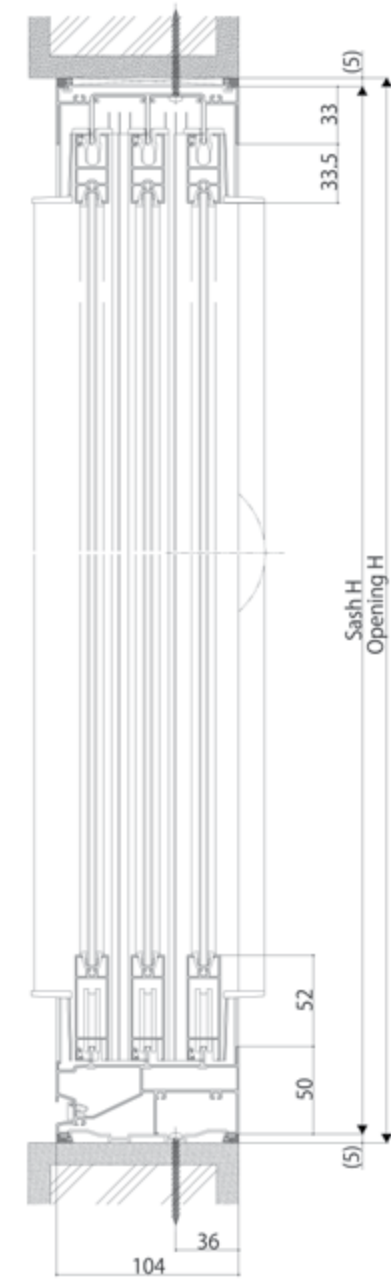

< Vertical section: 3 panels sliding window >

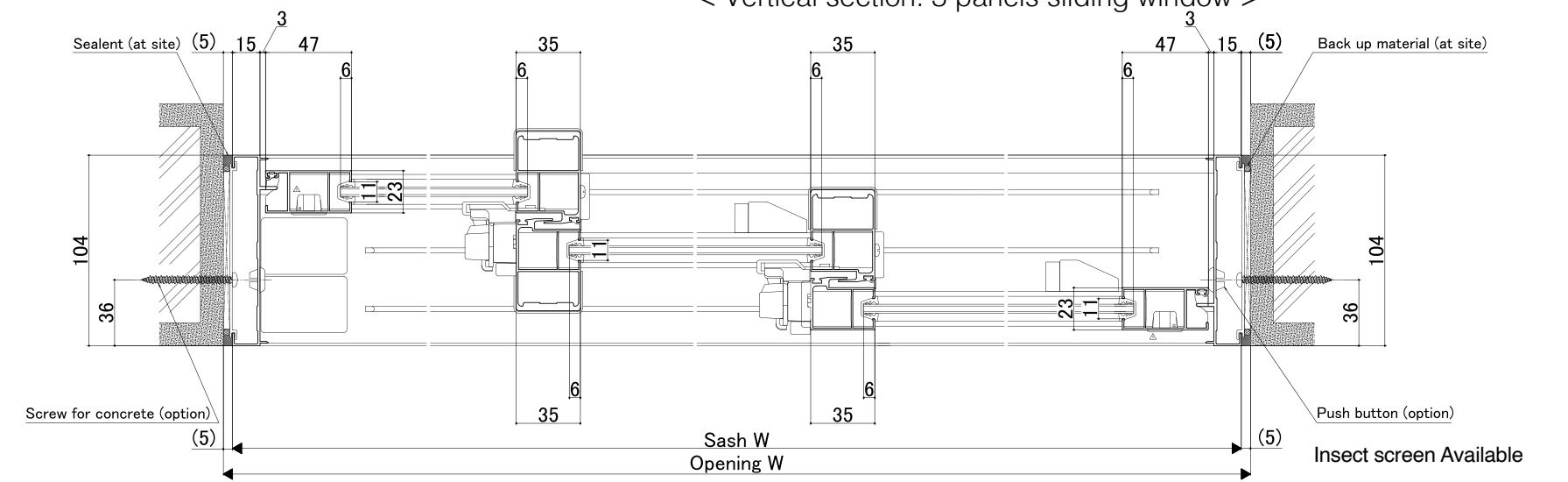

< Horizontal section: 3 panels sliding window >



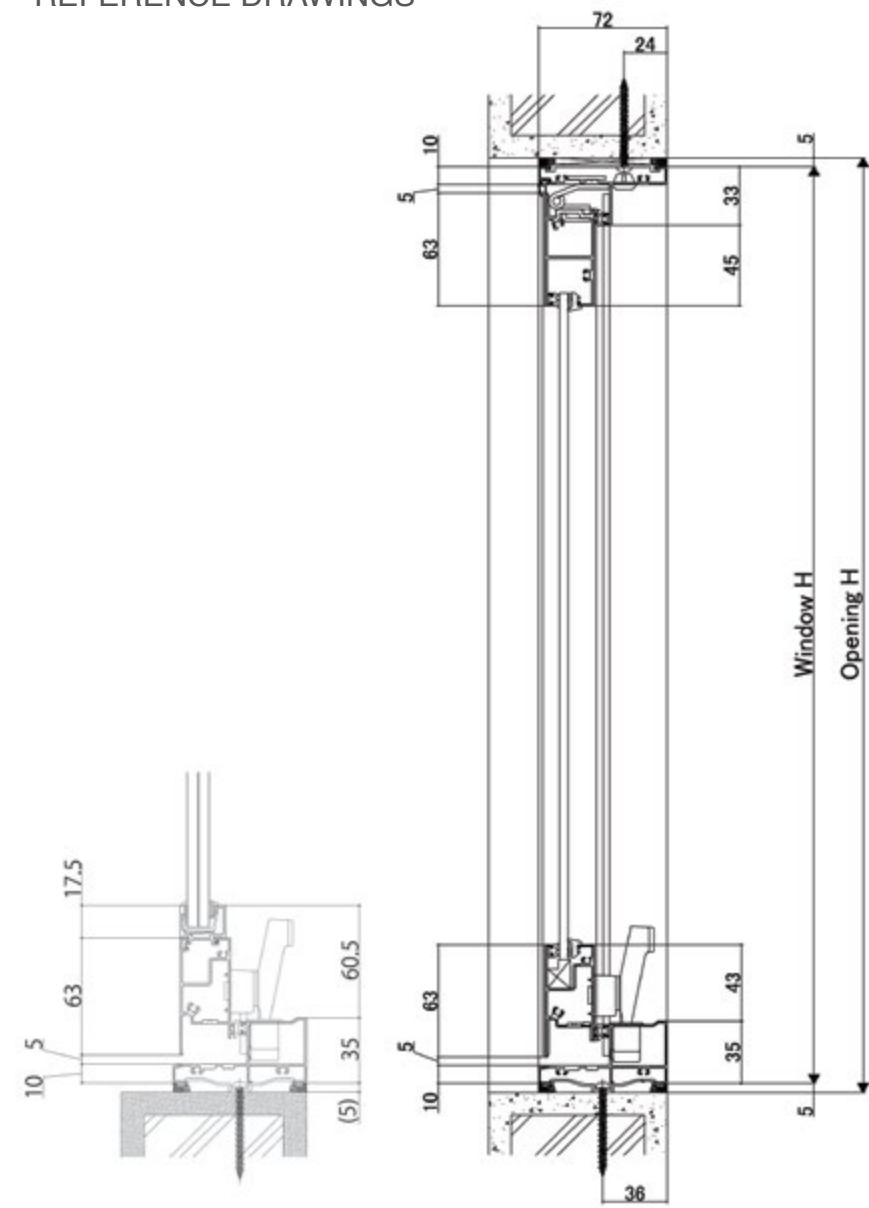

< Vertical section: Awning (single lock) >

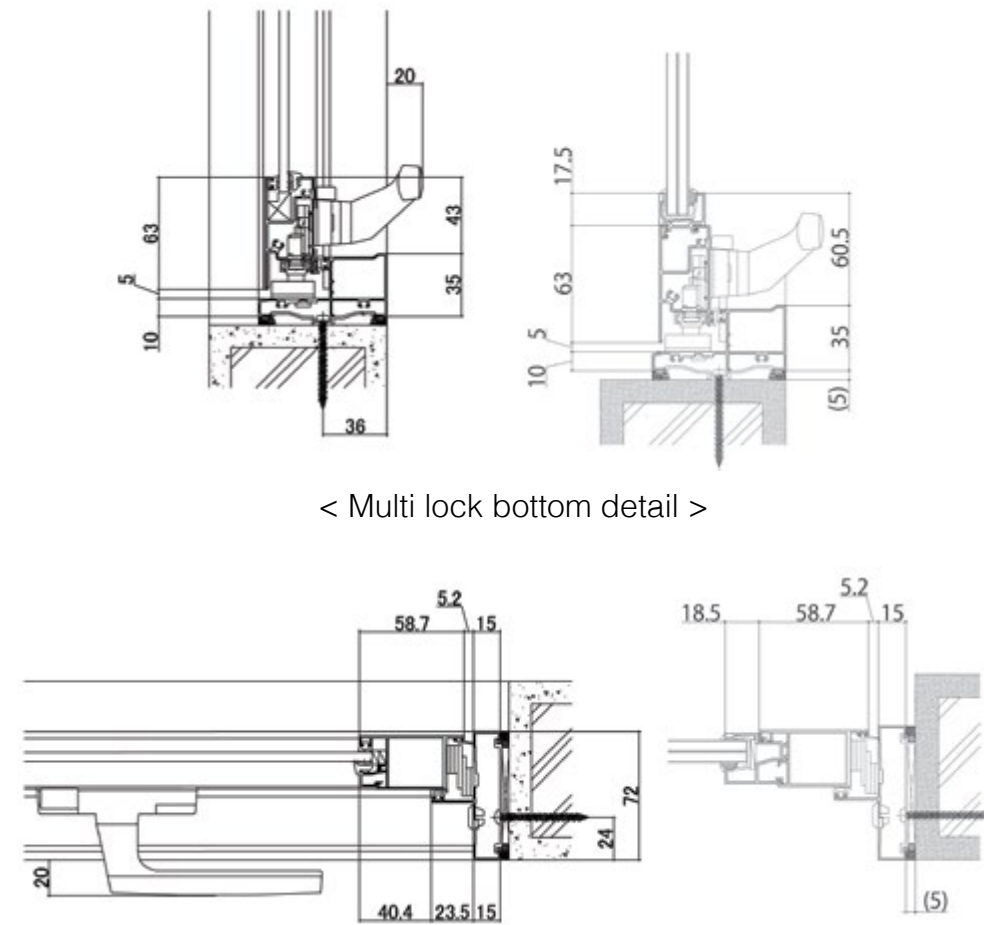

< Multi lock bottom detail >

< Multi lock jamb detail >

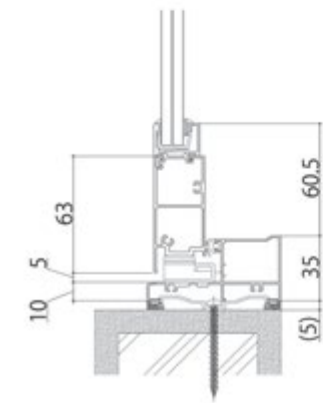

< Horizontal section: Casement (single lock) >

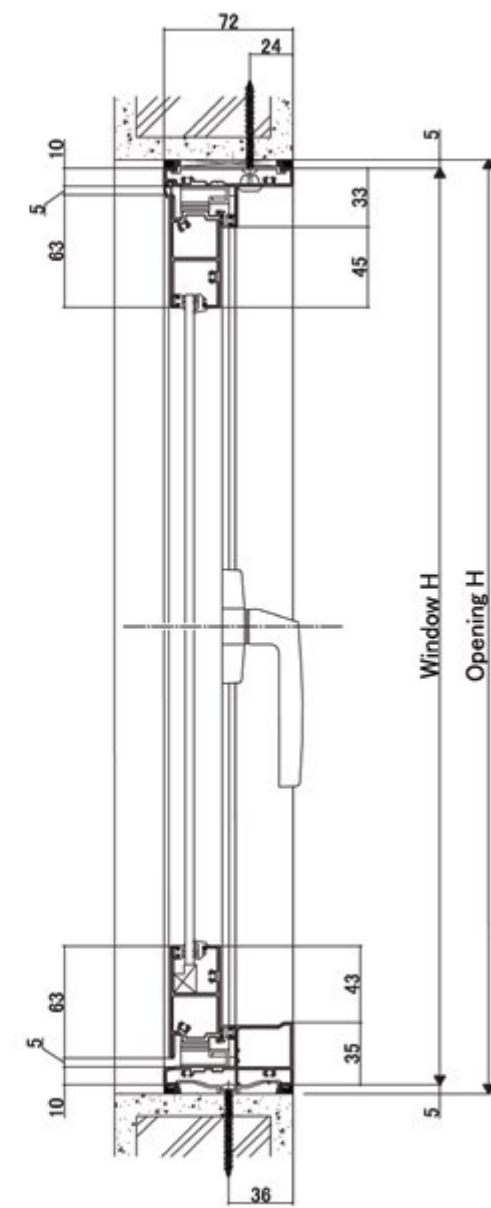

< Vertical section: Casement (single lock) >

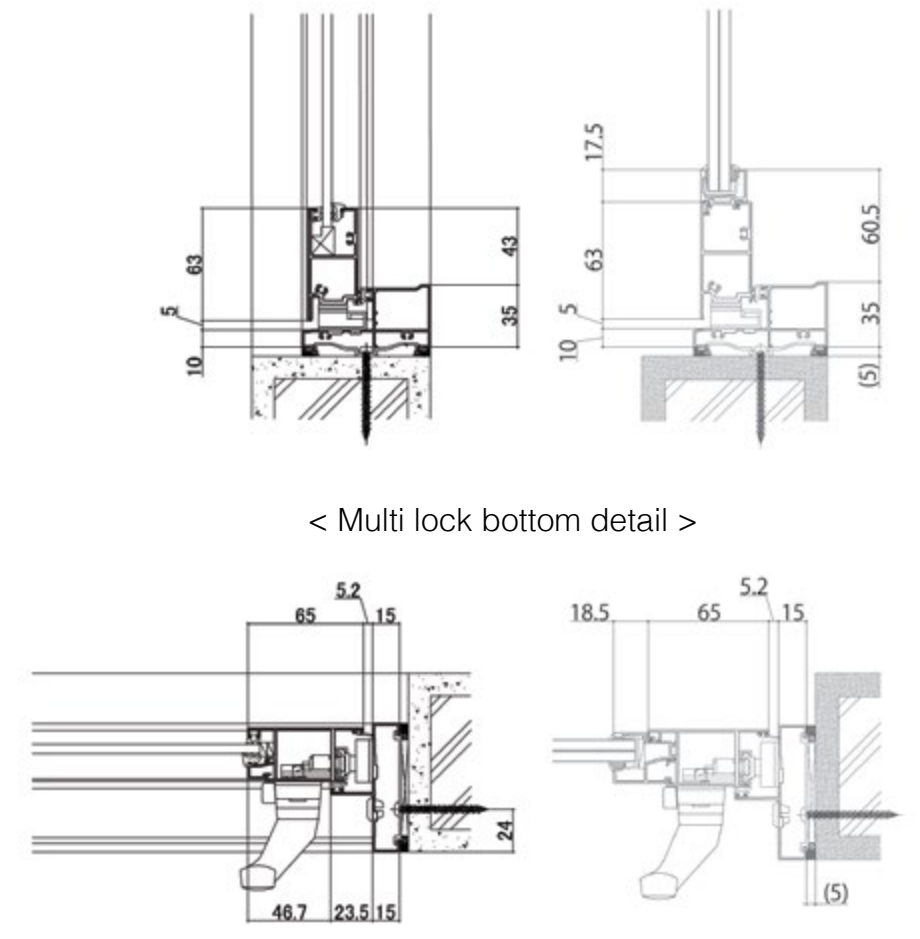

< Multi lock bottom detail >

< Multi lock jamb detail >

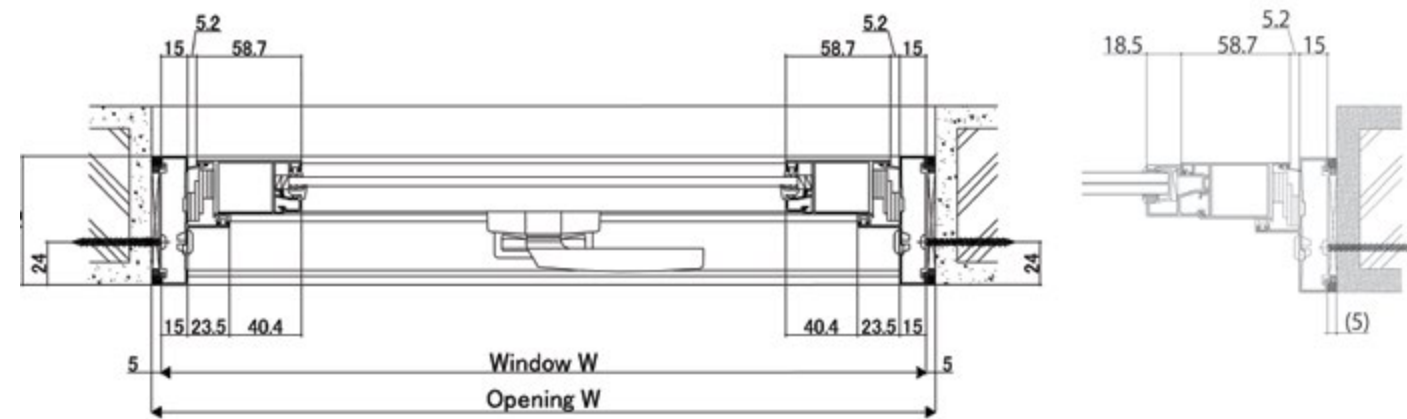

< Horizontal section: Awning (single lock) >

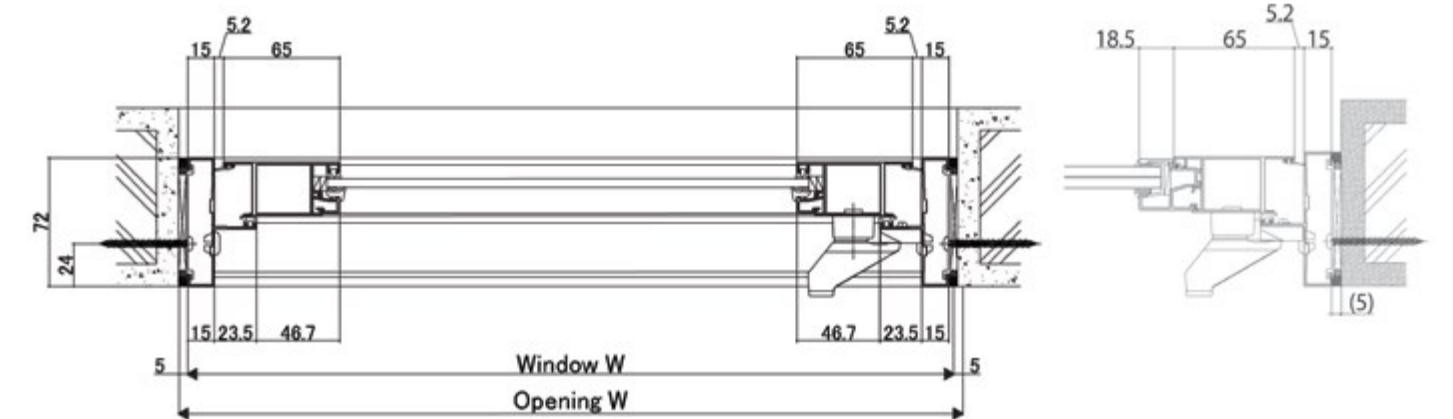

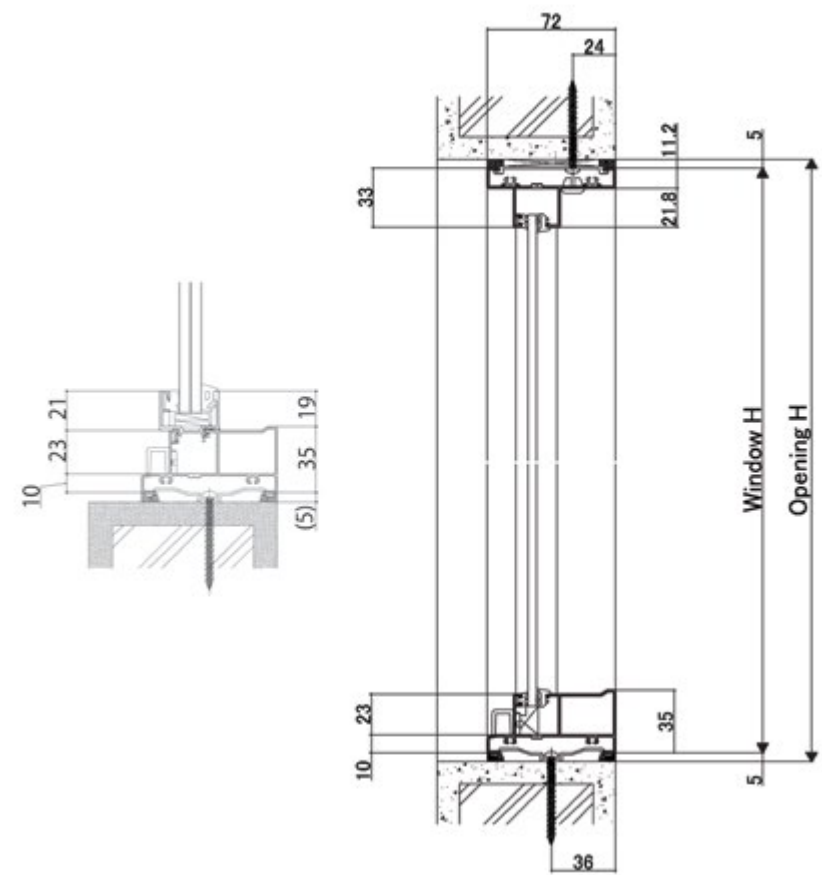

< Vertical section: Single and corner fixed window >

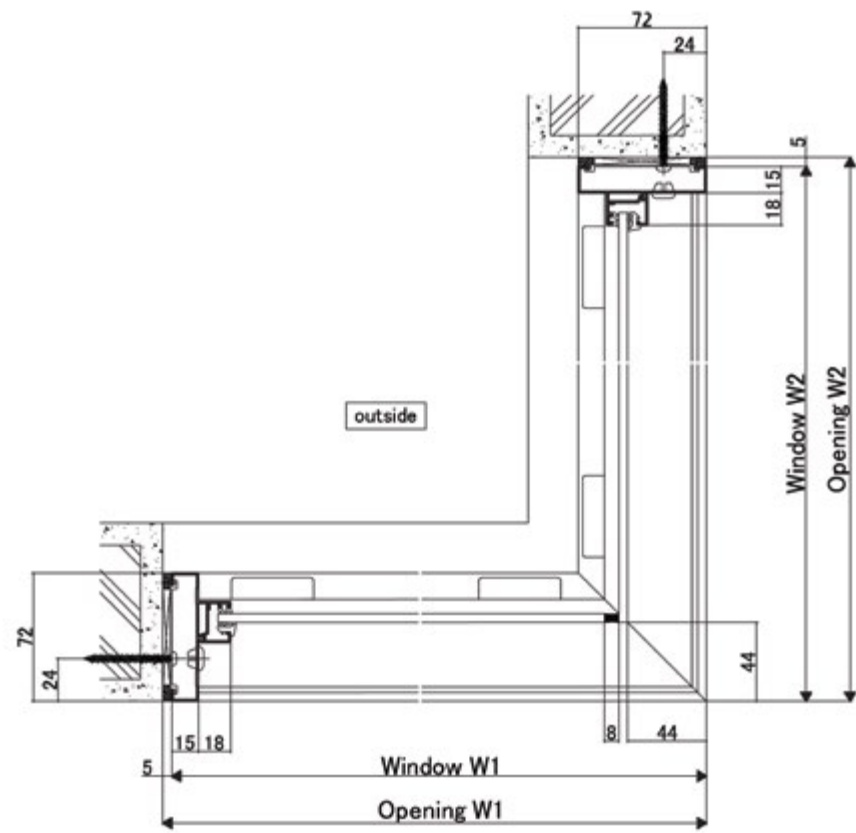

< Horizontal section: Inward fixed window >

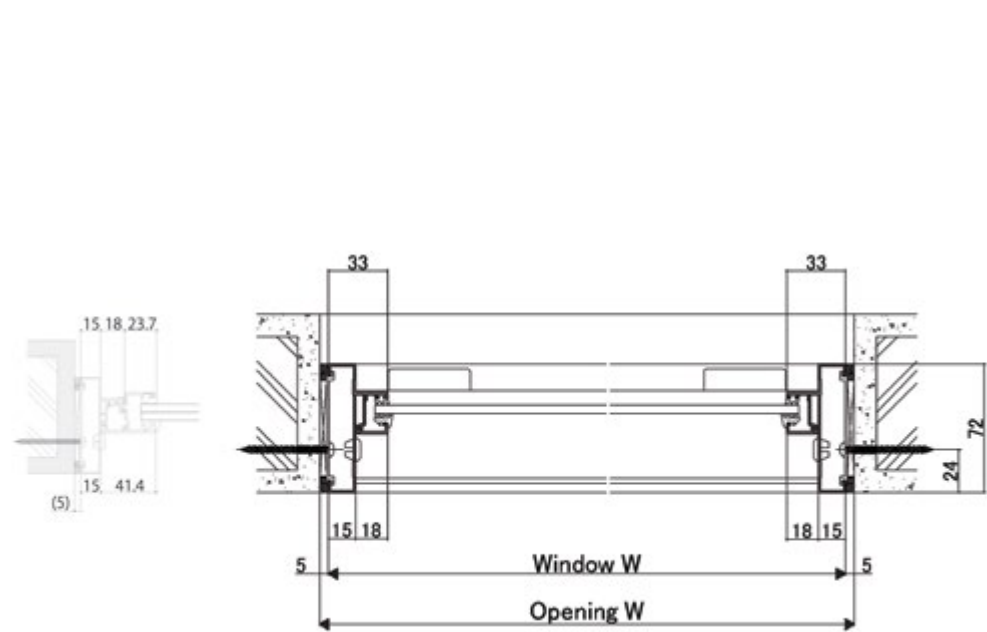

< Horizontal section: Outward fixed window >

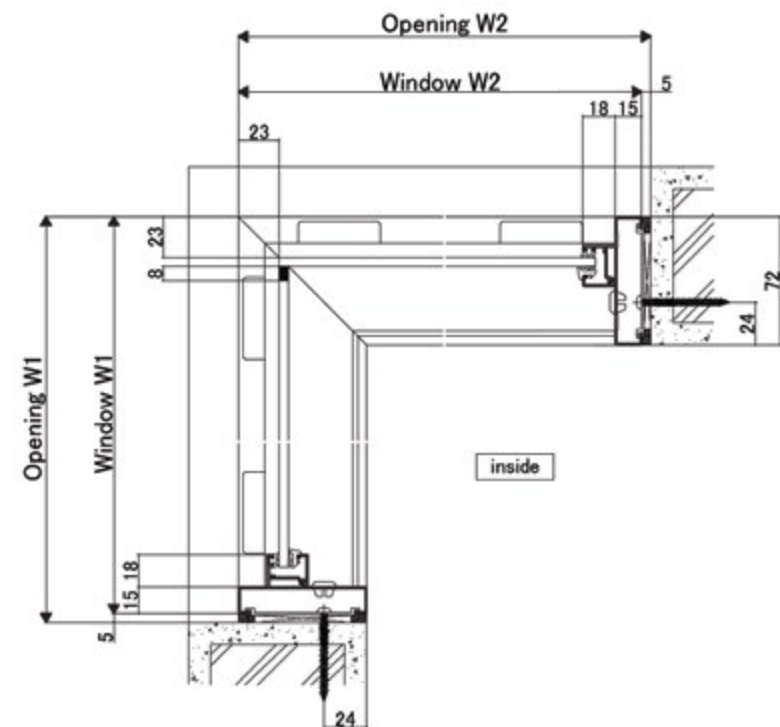

< Horizontal section: Outward fixed window >

**WE PLUS DOOR SERIES**

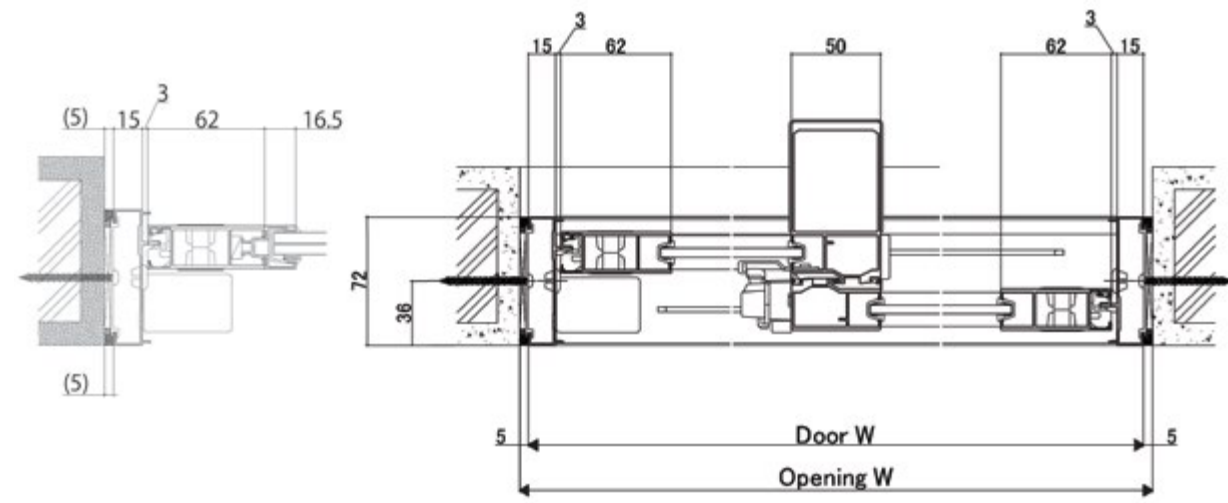

< Horizontal section: 2 panels sliding door >

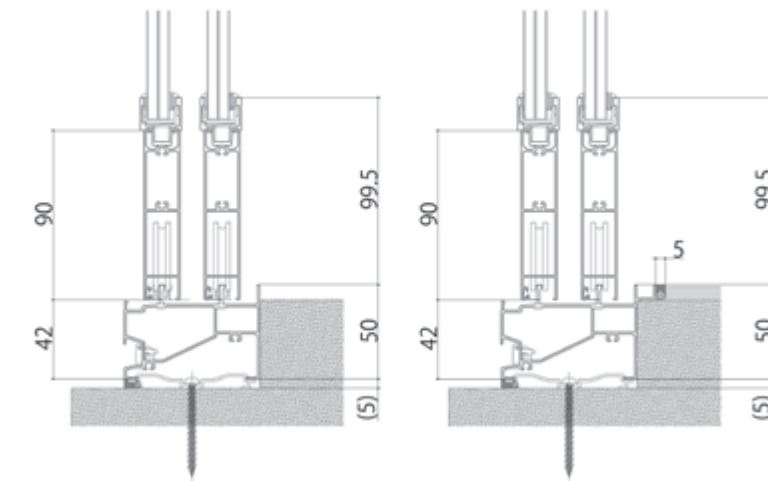

< Vertical section: 2 and 4 panels sliding door >

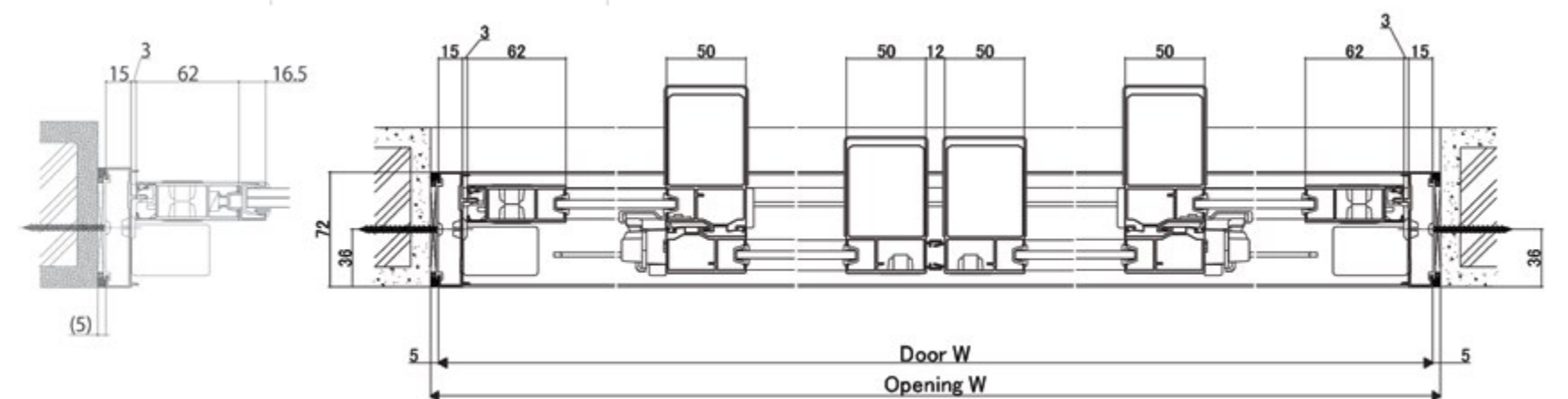

< Horizontal section: 4 panels sliding door >



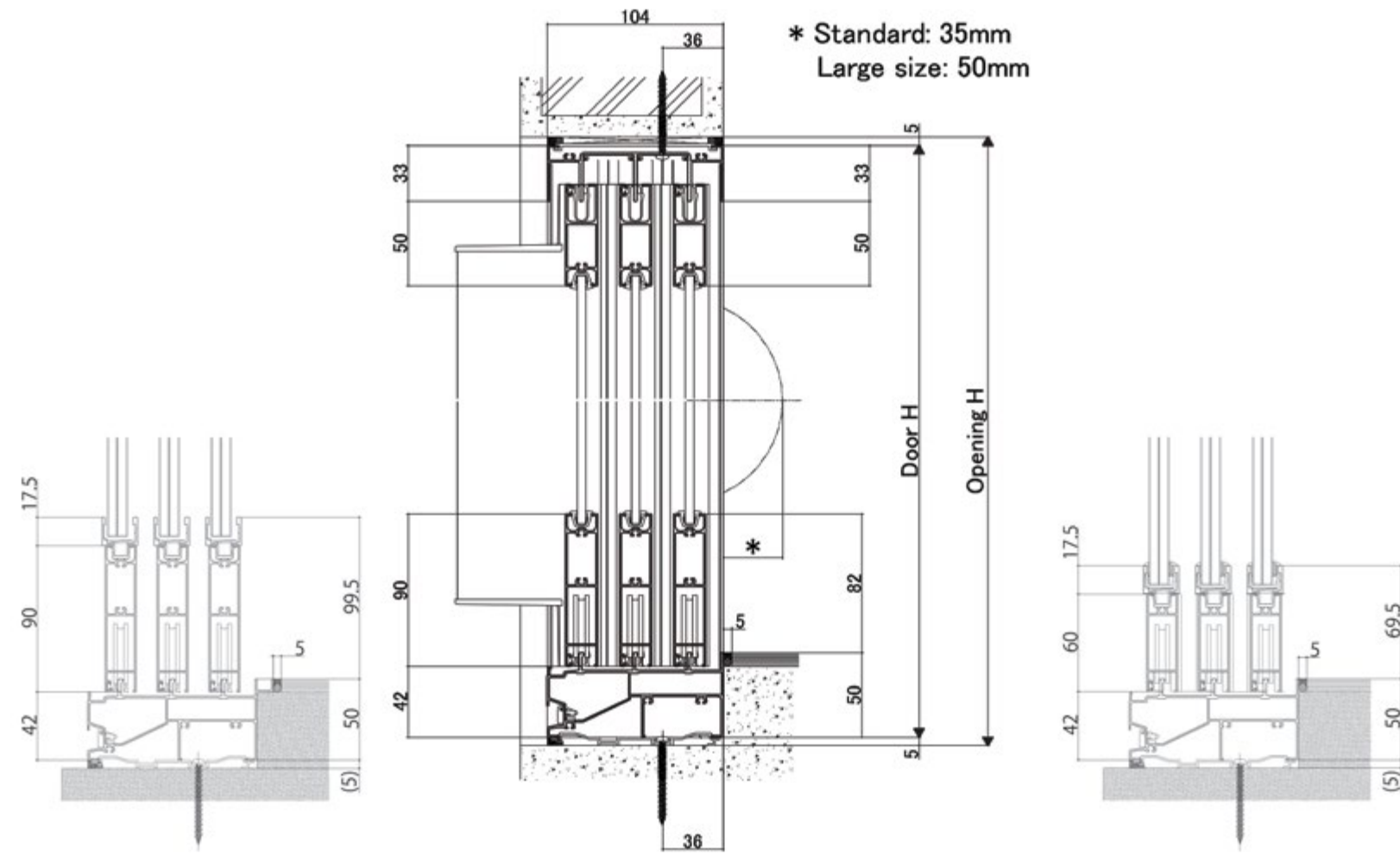

< Vertical section: 3 panels sliding door >

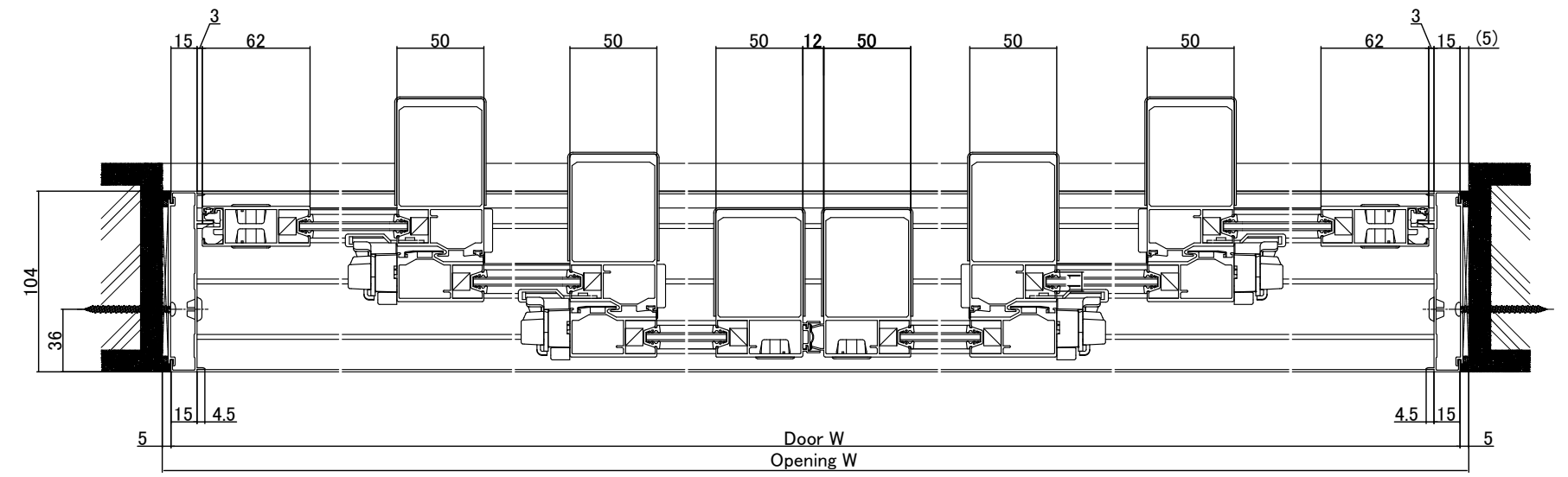

< Horizontal section : 6 panels Sliding door >

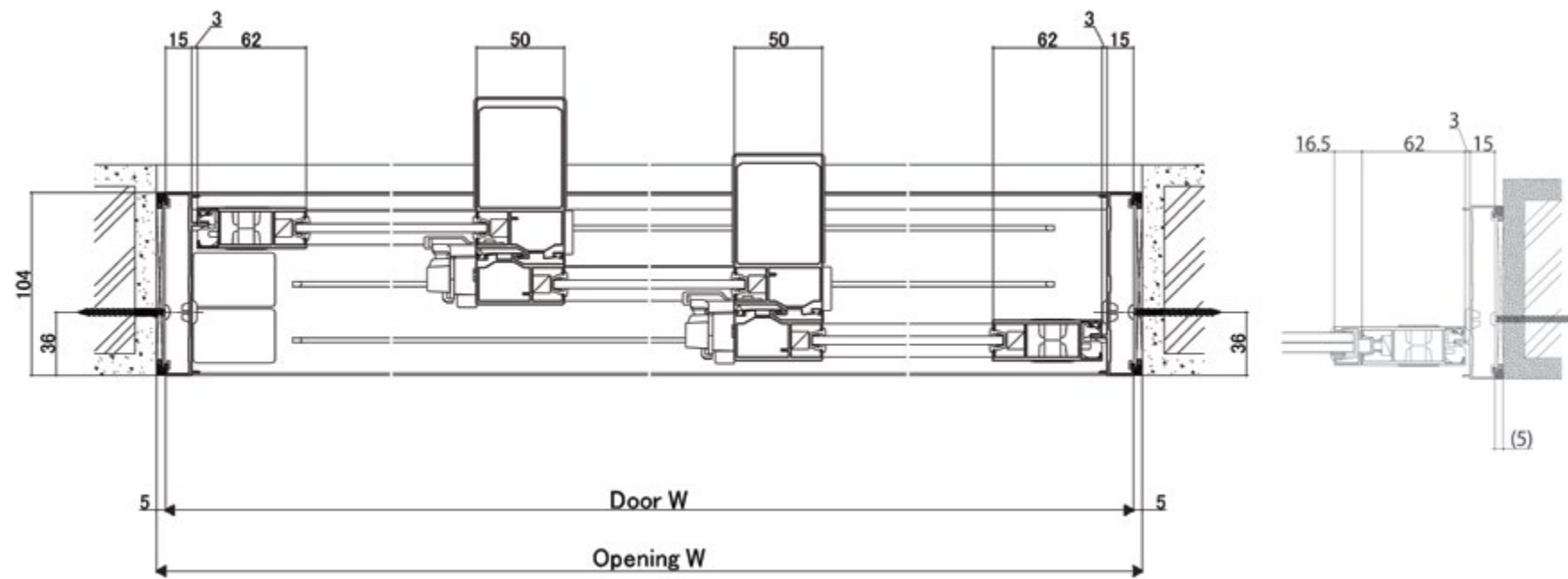

< Horizontal section: 3 panels sliding door >

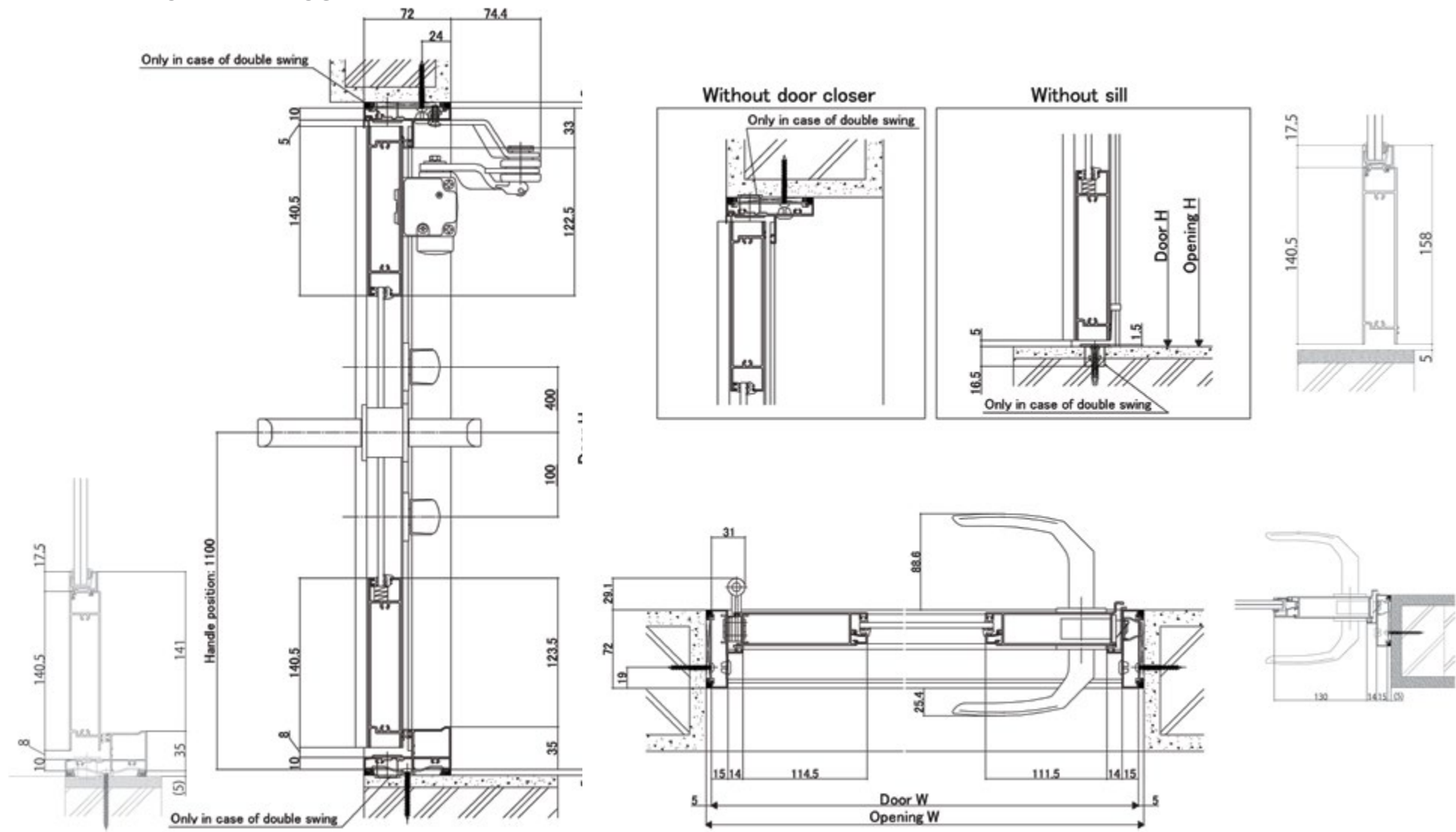

< Vertical section: Single & double out-swing door with sill >

< Horizontal section: Single out-swing door >

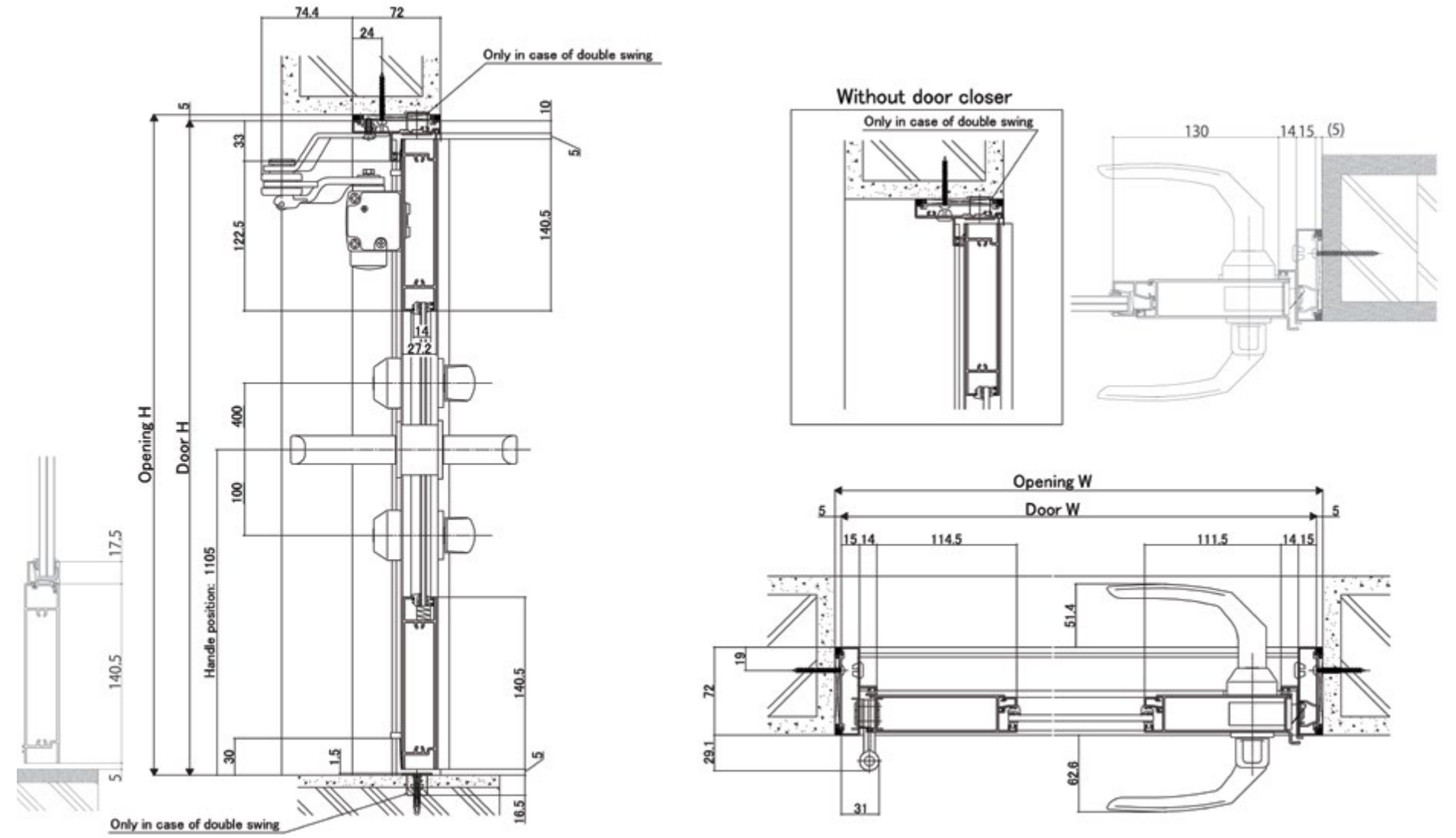

< Vertical section: Single & double in-swing door >

< Horizontal section: Single in-swing door >

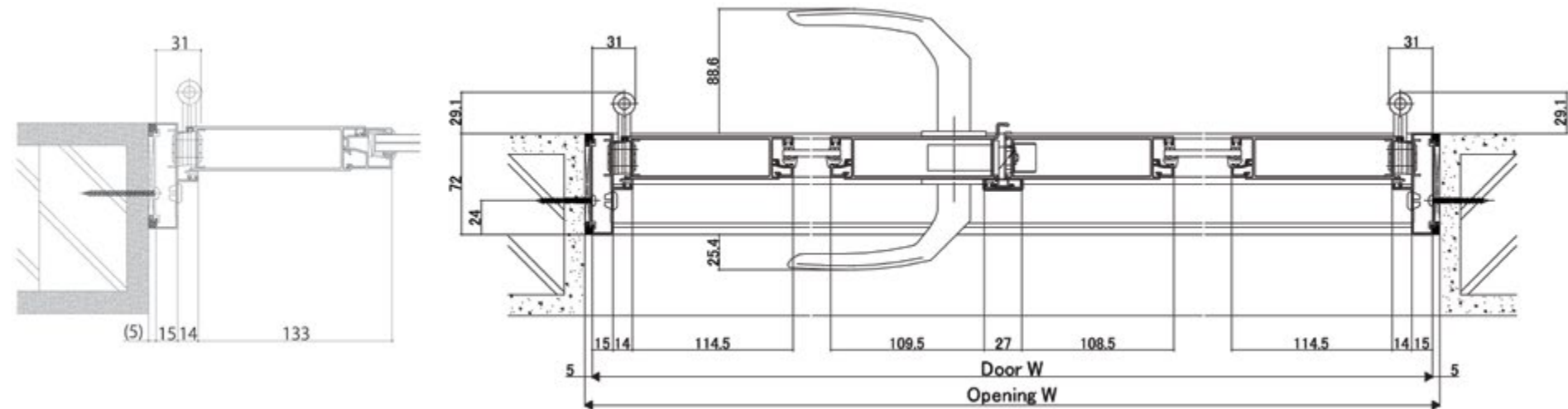

< Horizontal section: Double out-swing door >

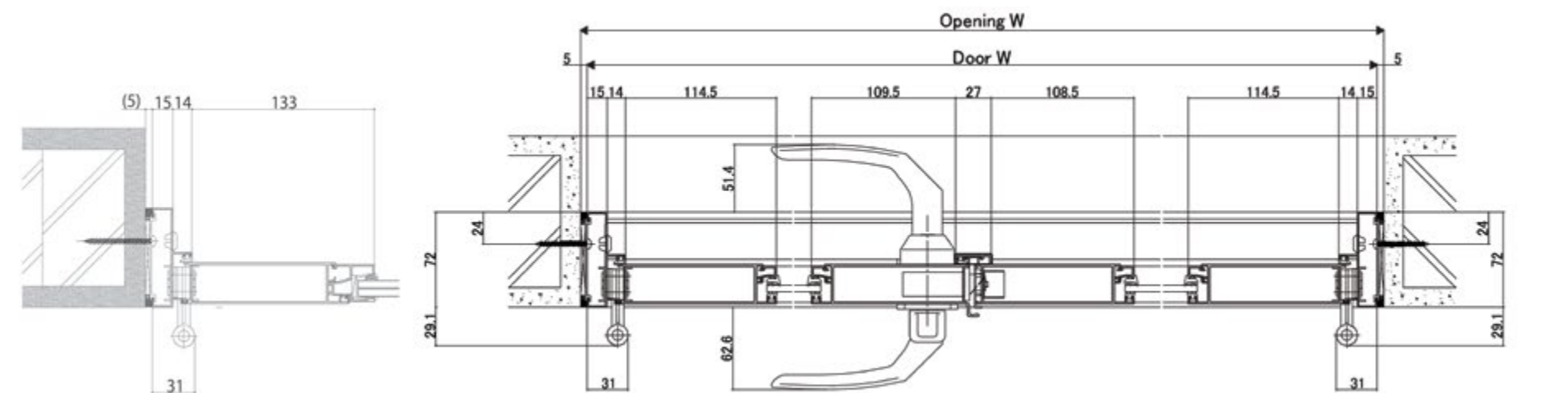

< Horizontal section: Double in-swing door >



**WE PLUS COMBINATION**

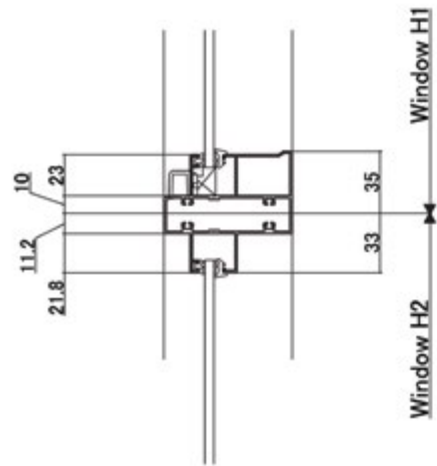

< Vertical: Fixed/Fixed transom >

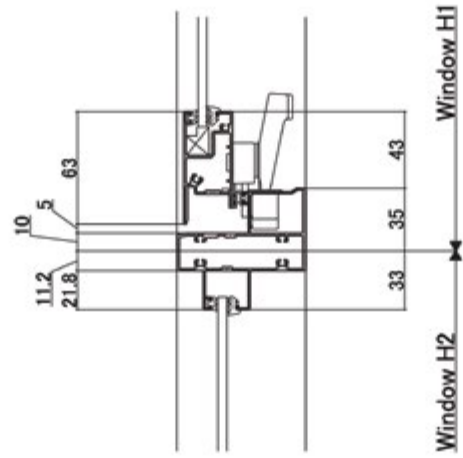

< Vertical: Projection/Fixed transom >

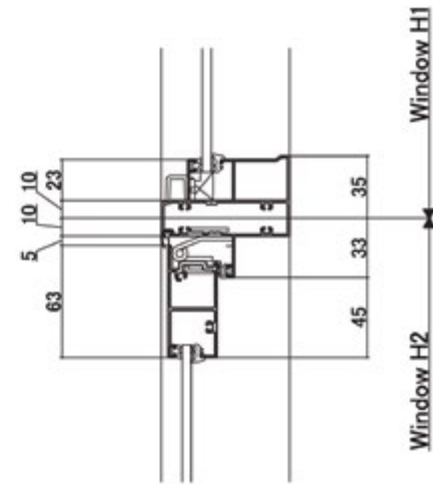

< Vertical: Fixed/Projection transom >

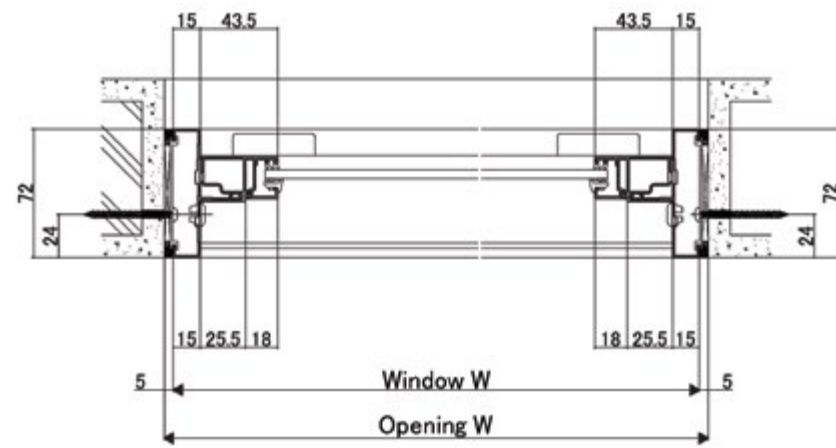

< Horizontal section: Combination fixed window >

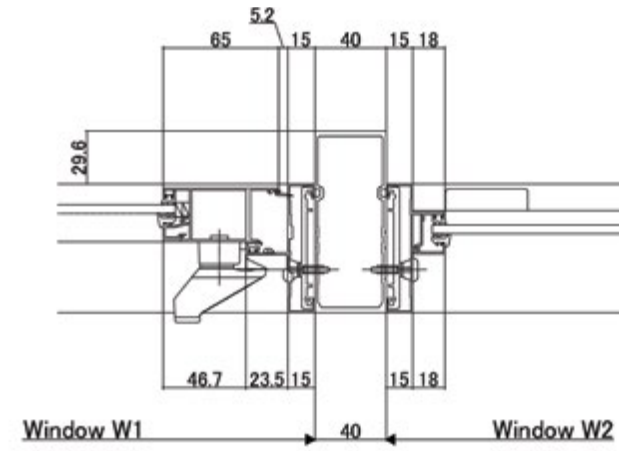

< Corner mullion (Large) >

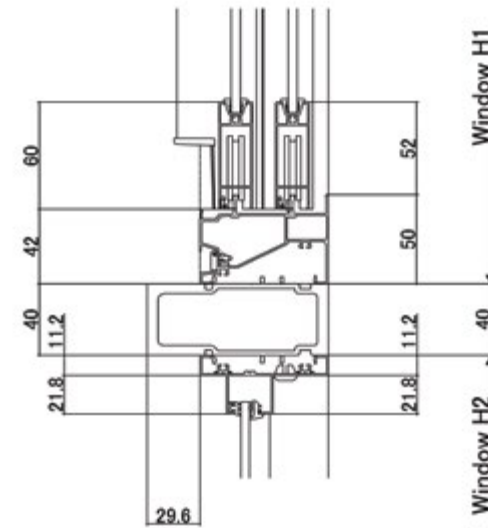

< Corner mullion (Large) >

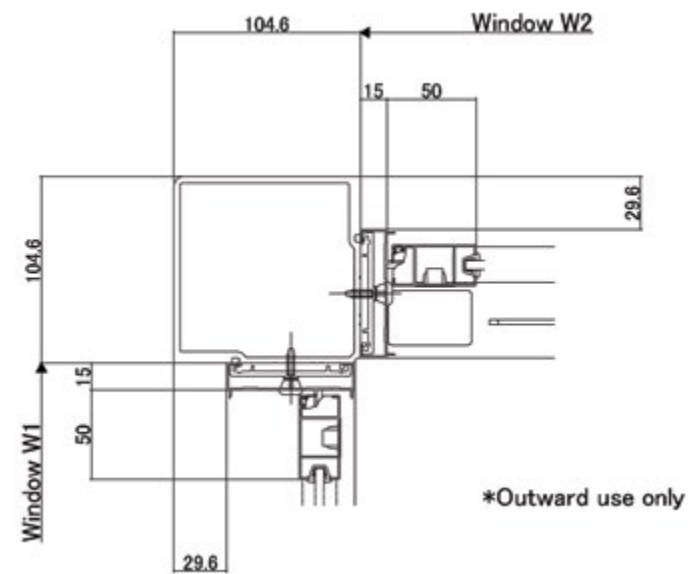

< Corner mullion (Large) >

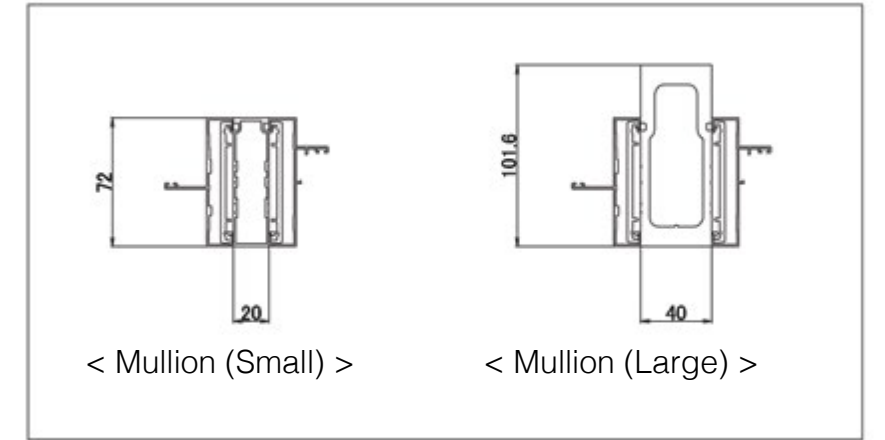

< Mullion (Small) >

< Mullion (Large) >

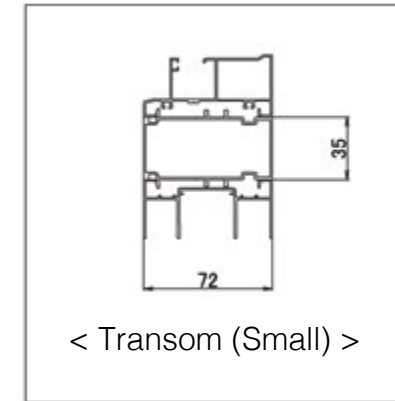

< Transom (Small) >

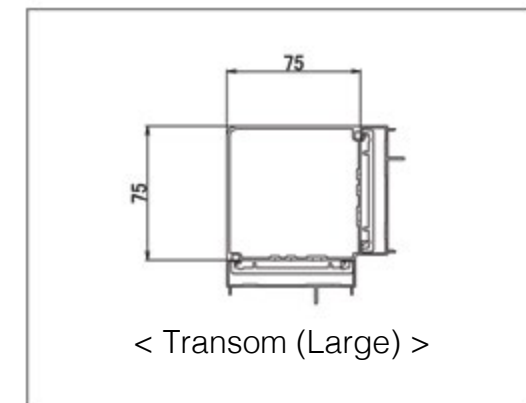

< Transom (Large) >

ATIS WINDOW SERIES

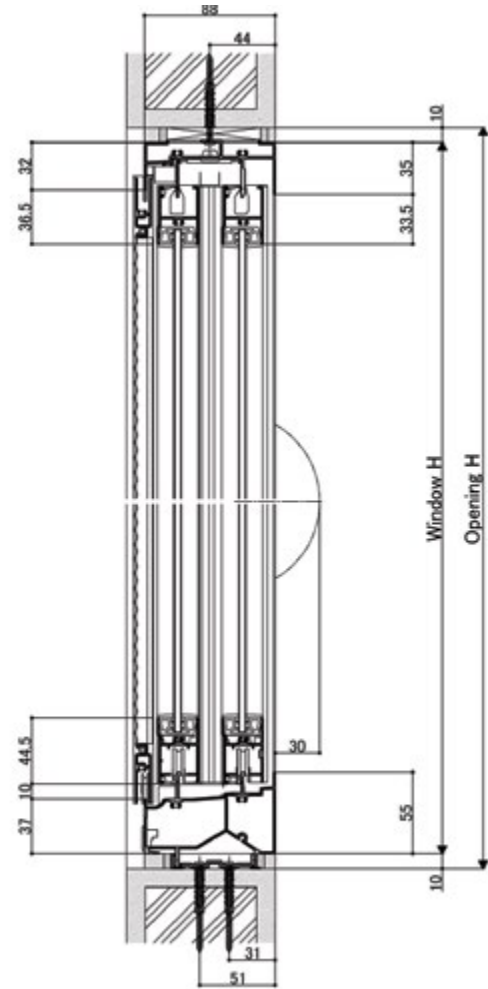

< Vertical section: 2 panels sliding window >

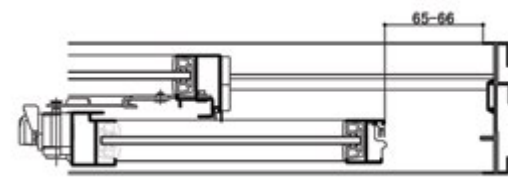

< Option (limit arm) Jamb detail >

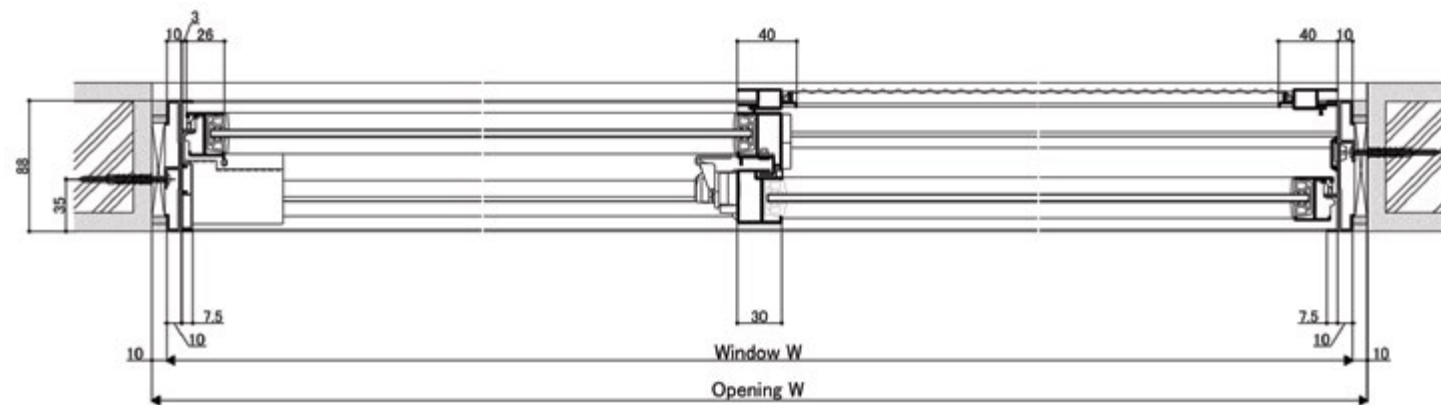

< Horizontal section: 2 panels sliding window >

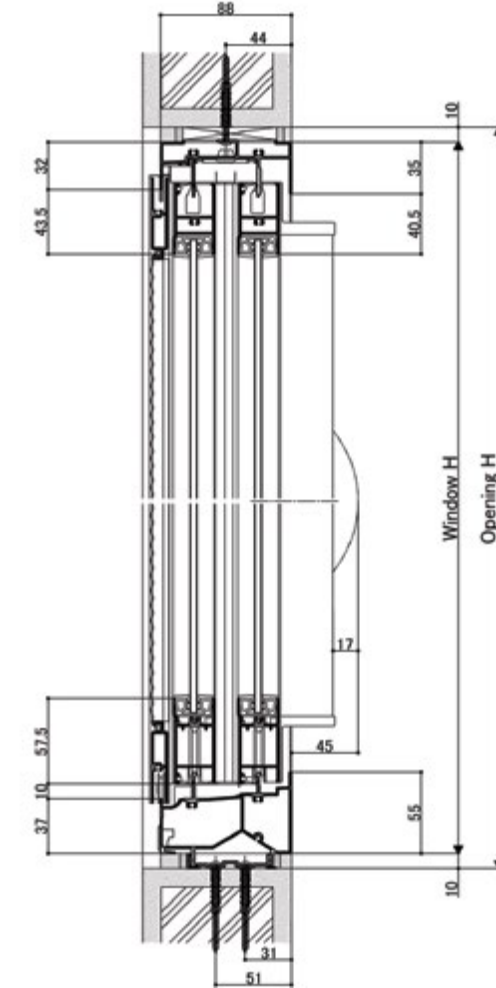

< Vertical section: 4 panels sliding window >

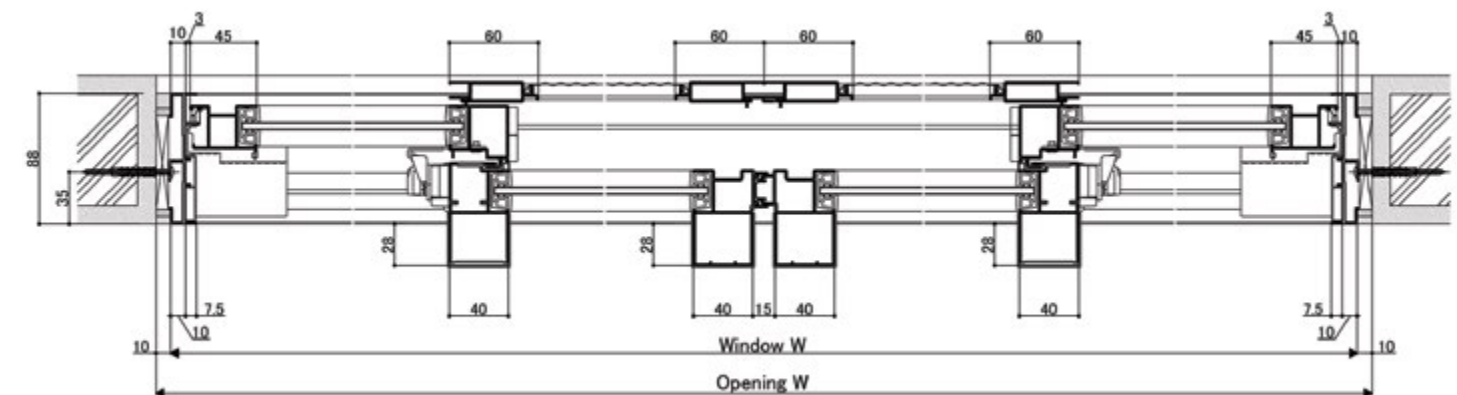

< Horizontal section: 4 panels sliding window >



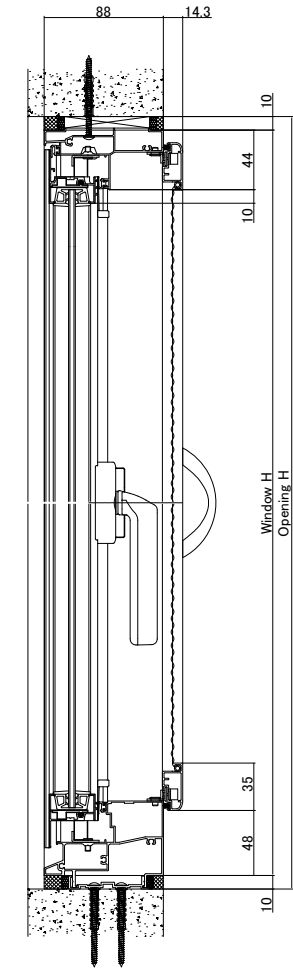
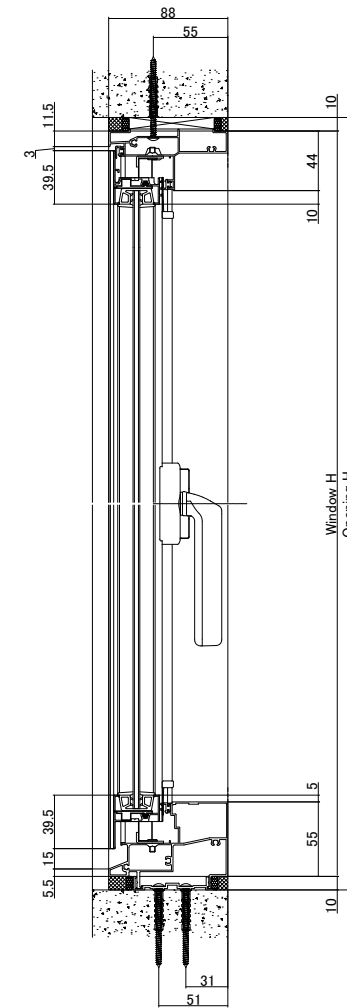
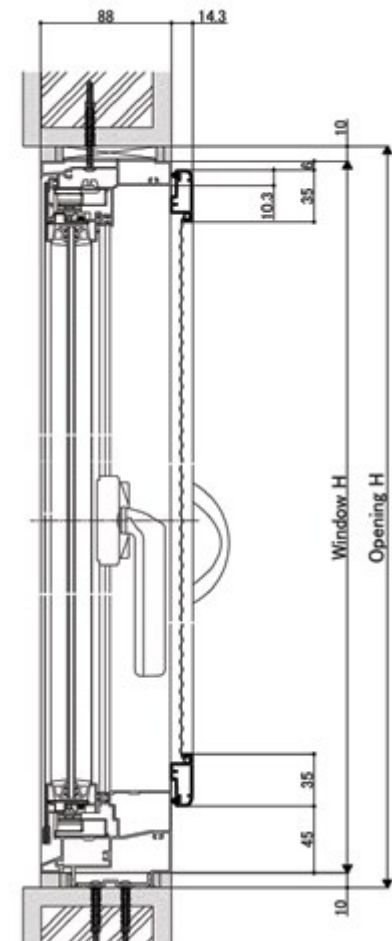
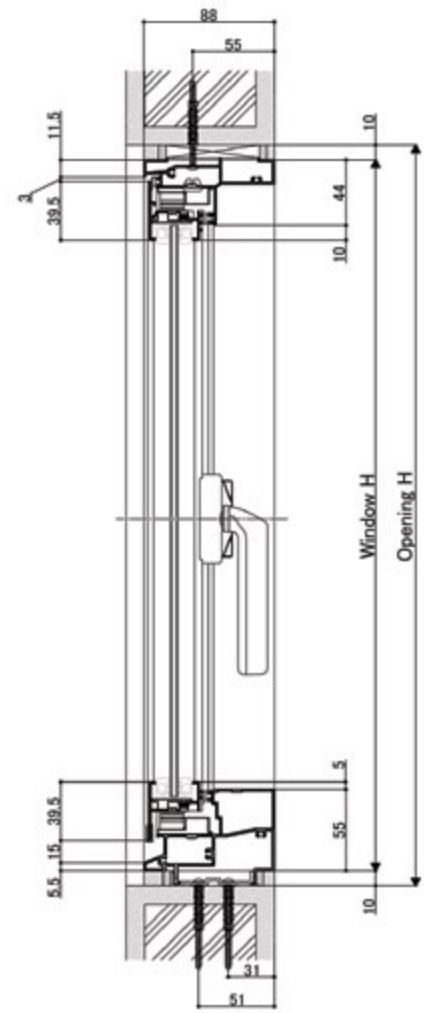

< Vertical section: Casement window (Single lock) >

< Vertical section: Casement with screen >

< Vertical section Double Casement Window >

< Vertical section Double Casement Window with Screen >

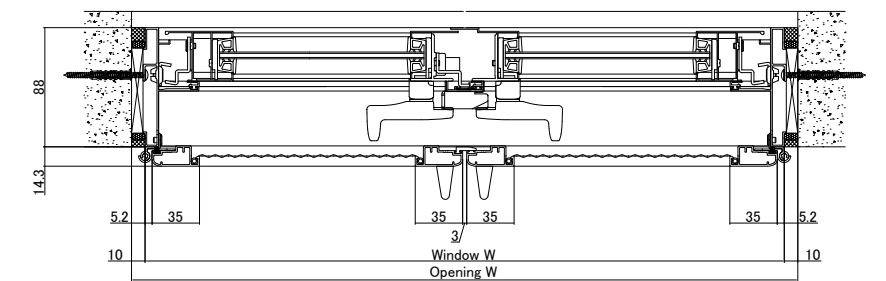
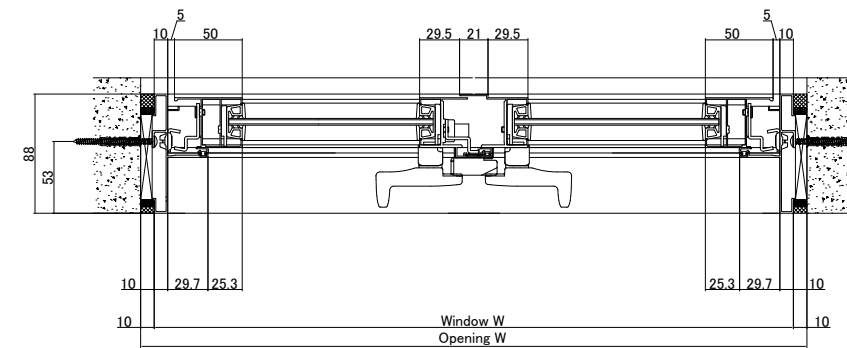
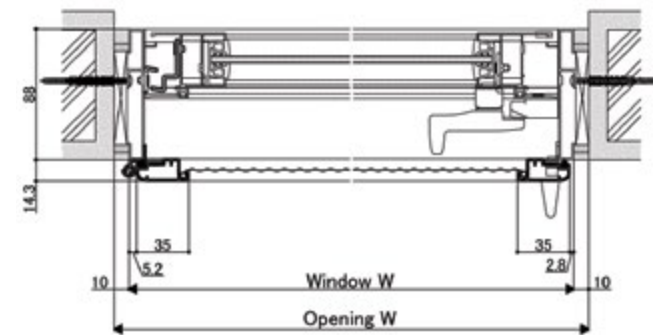
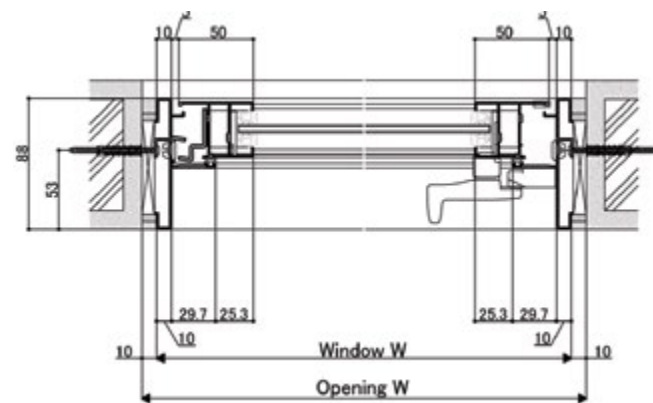

< Horizontal section: Casement window (Single lock) >

< Horizontal section: Casement with screen >

< Horizontal section: Double Casement Window >

< Horizontal section: Double Casement Window with Screen >

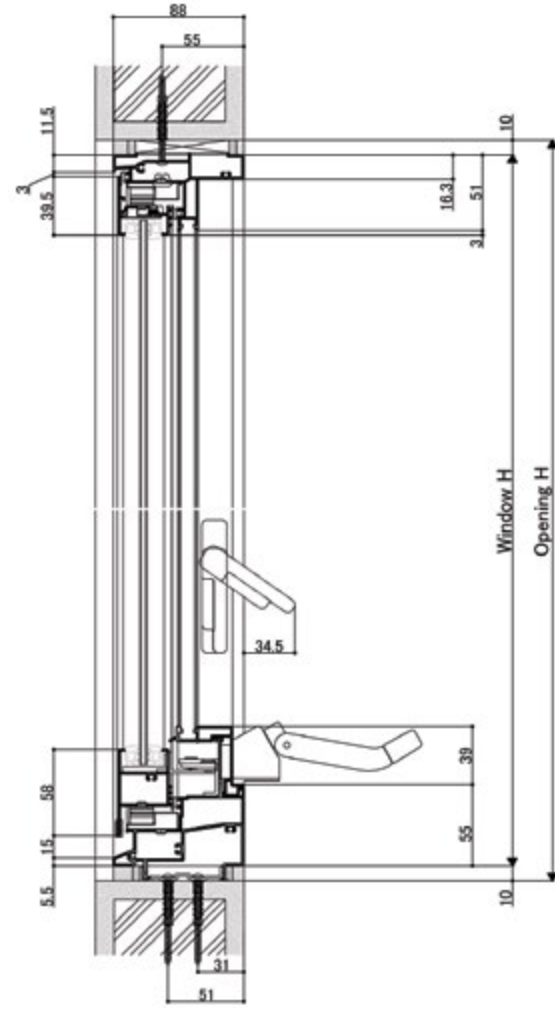

< Vertical section: Casement operator window >

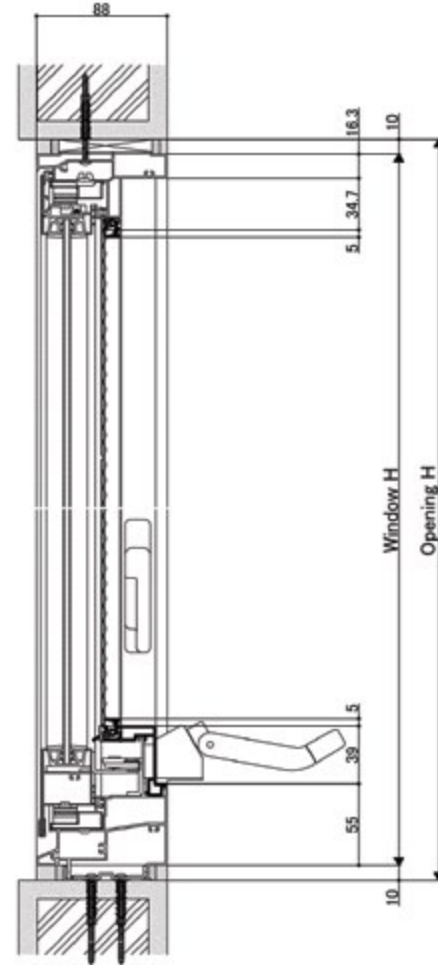

< Vertical section: Casement with screen >

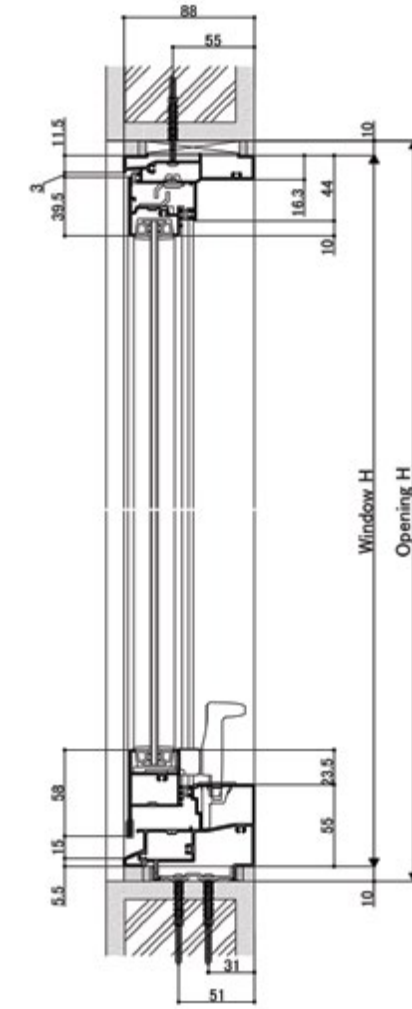

< Vertical section: Awning window (Single lock) >

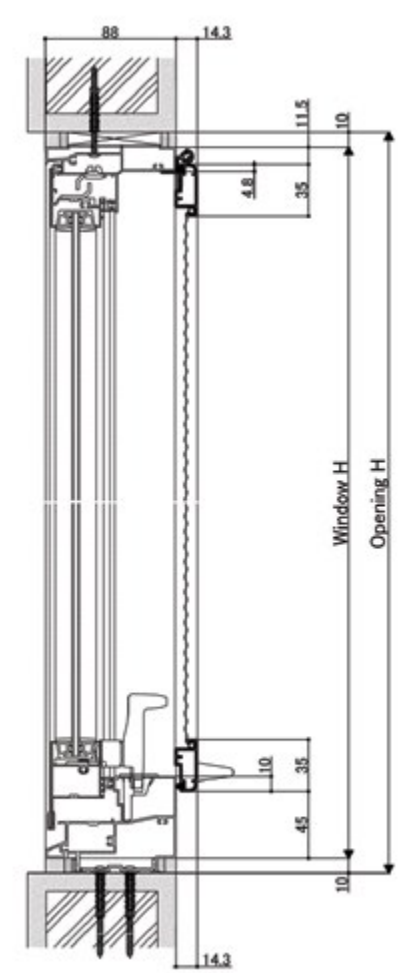

< Vertical section: Awning with screen >

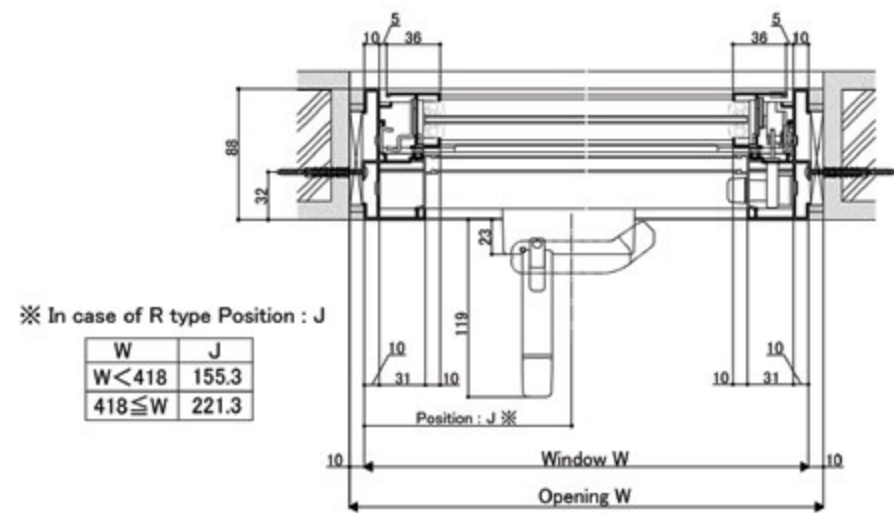

< Horizontal section: Casement operator window >

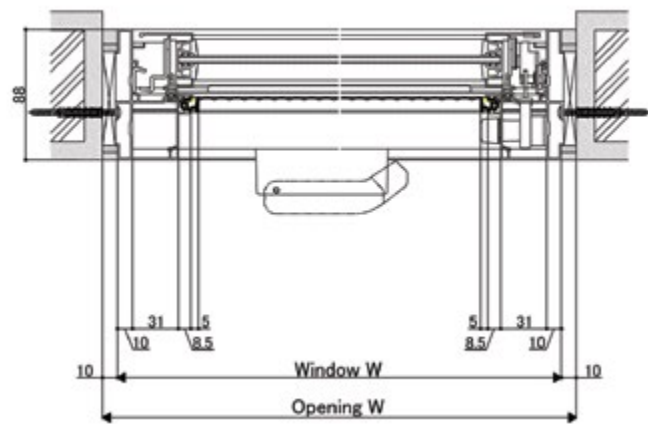

< Horizontal section: Casement with screen >

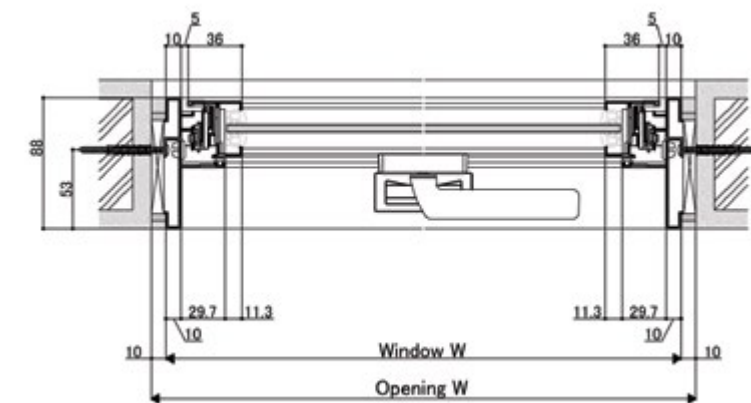

< Horizontal section: Awning window (Single lock) >

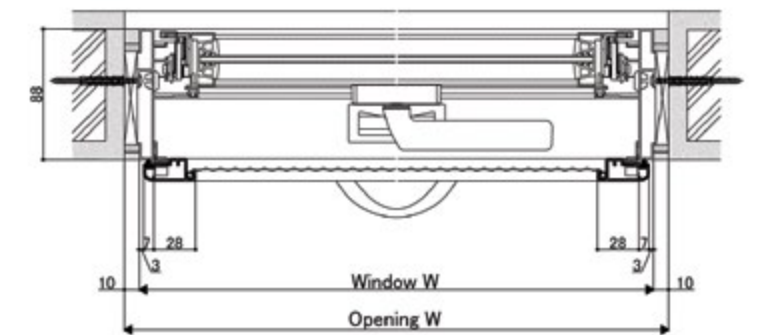

< Horizontal section: Awning with screen >



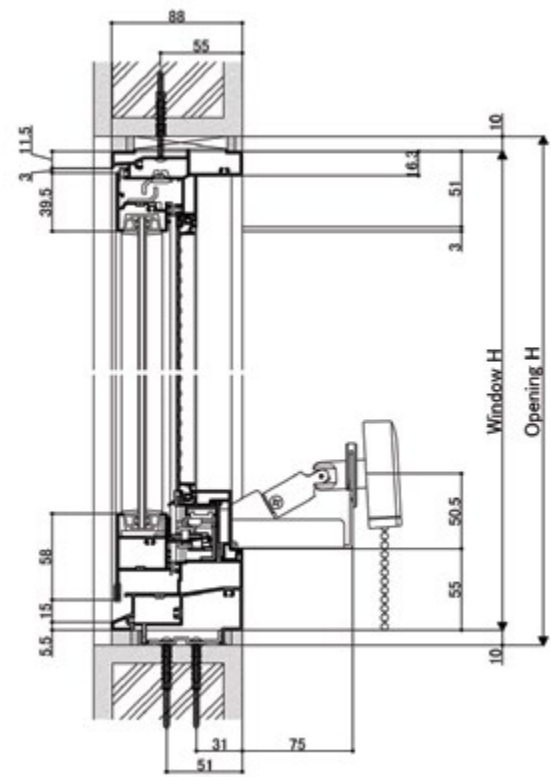

< Vertical section: Awning Slit window (chain set) >

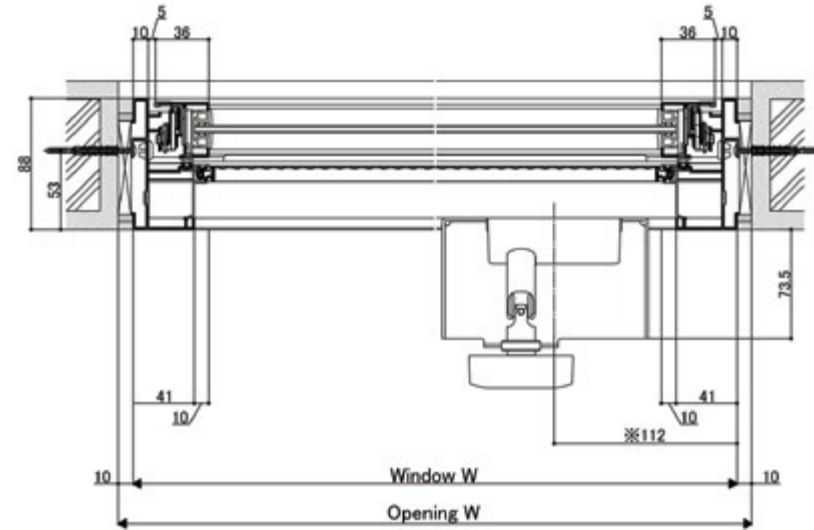

< Horizontal section: Awning Slit window (chain set) >

※ In case of R type

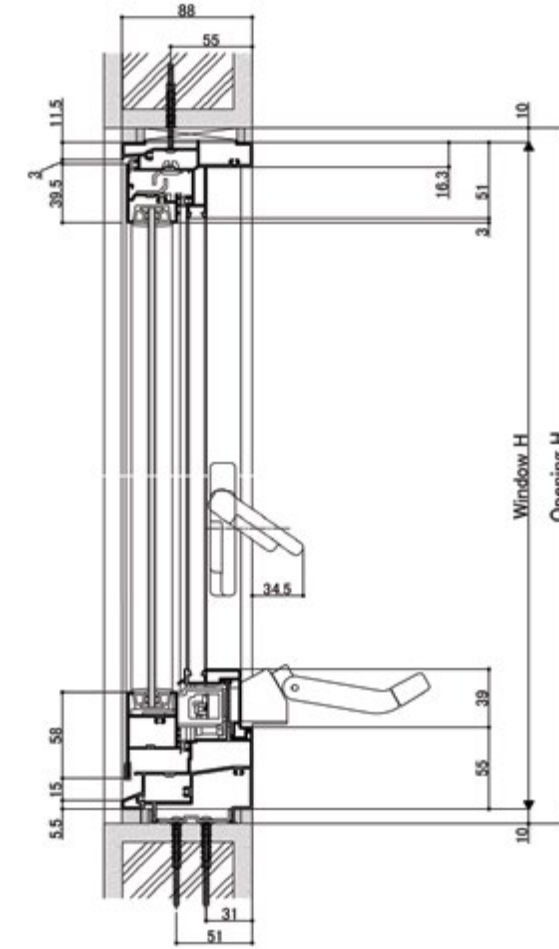

< Vertical section: Awning operator window >

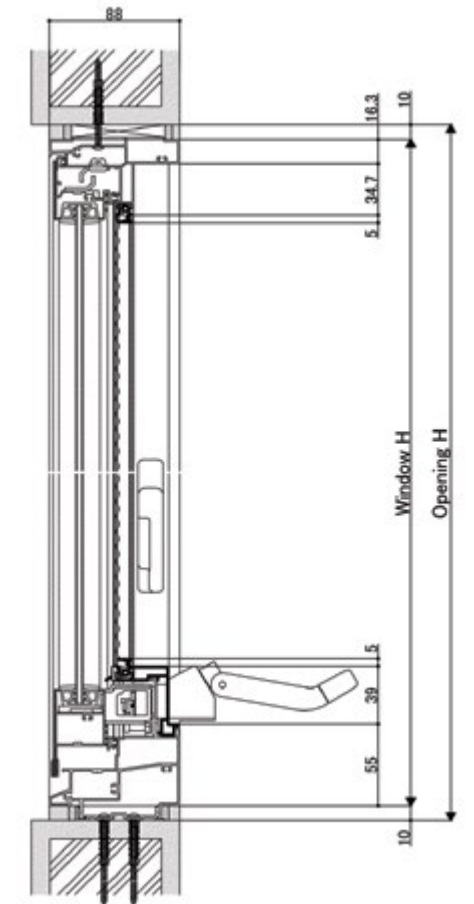

< Vertical section: Awning operator window with screen >

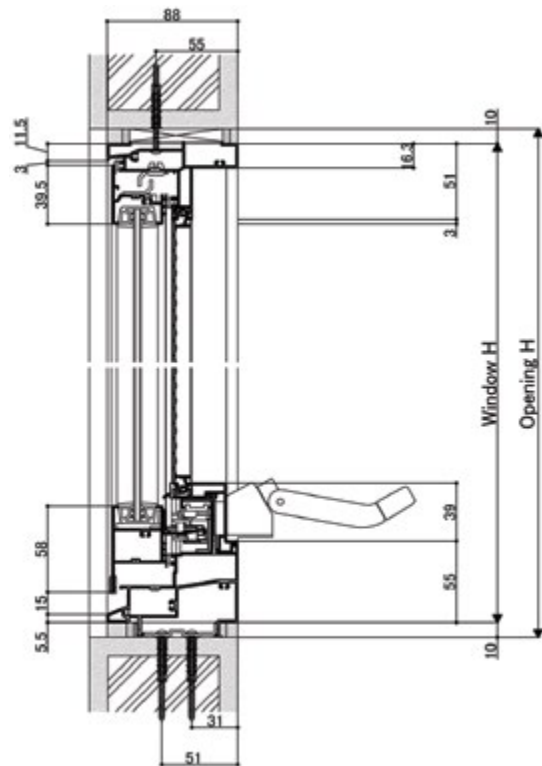

< Vertical section: Awning Slit window (operator set) >

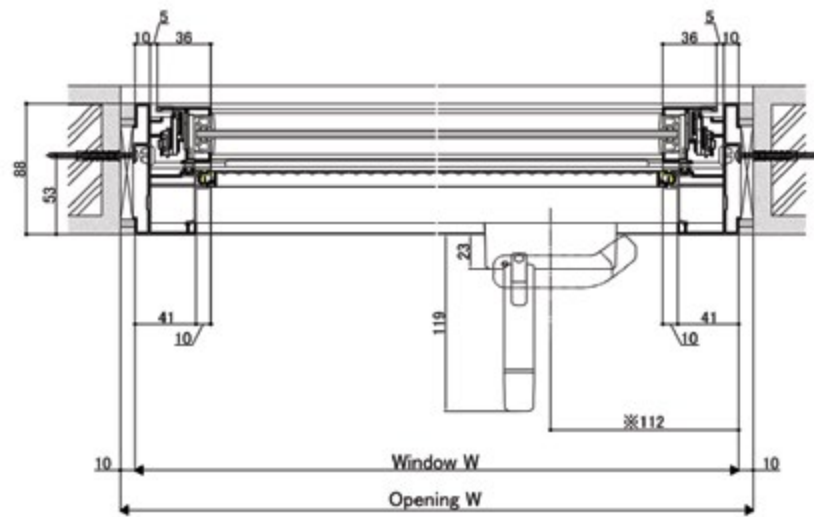

< Horizontal section: Awning Slit window (operator set) >

※ In case of R type

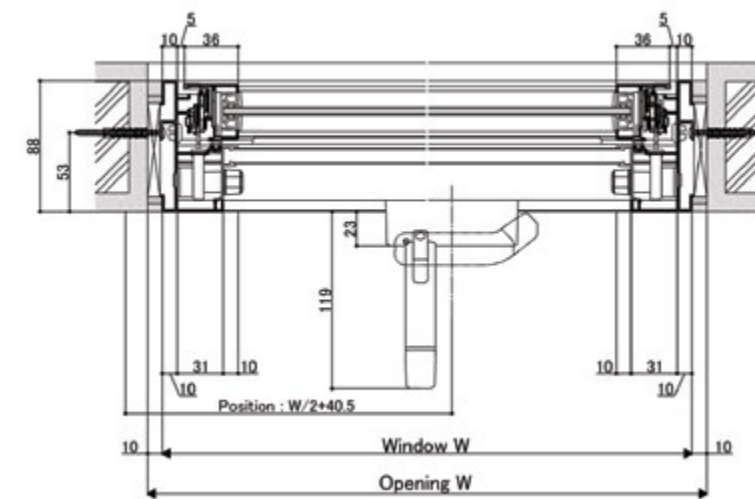

< Horizontal section: Awning operator window >

Position :  $W/2+40.5$

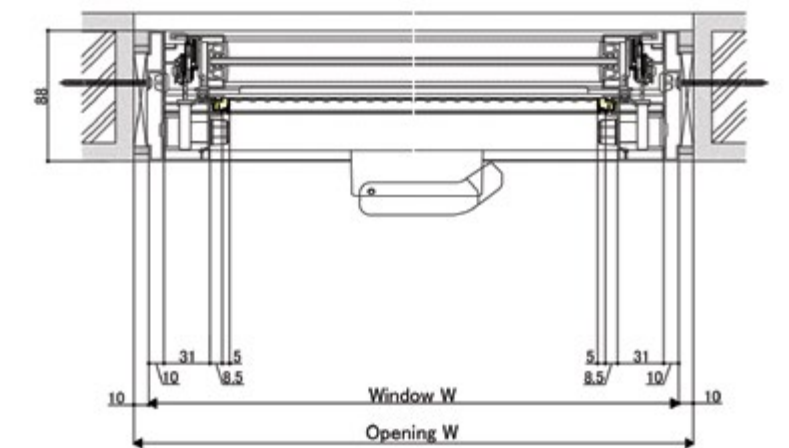

< Horizontal section: Awning operator window with screen >

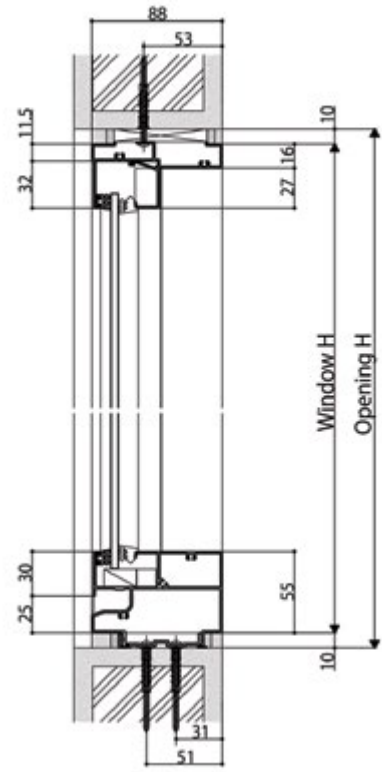

< Vertical section:  
Single and corner fixed window >

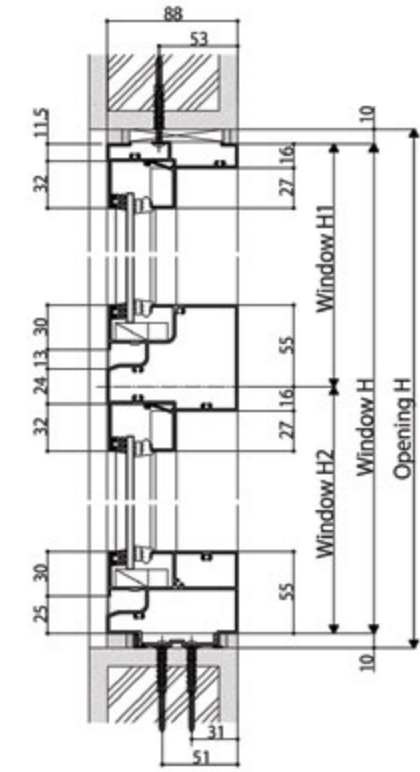

< Vertical section:  
Fixed window with transom >

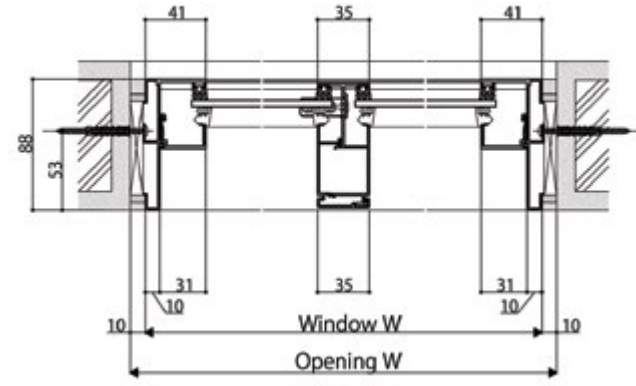

< Horizontal section:  
Fixed window with mullion >



< Vertical section: Single fixed window (IG unit) >

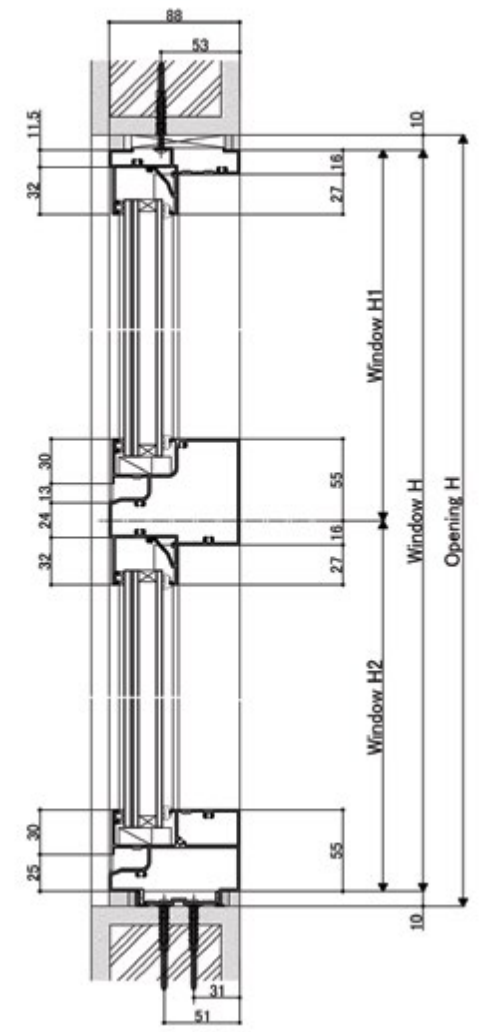

< Vertical section: Fixed window with transom (IG unit) >

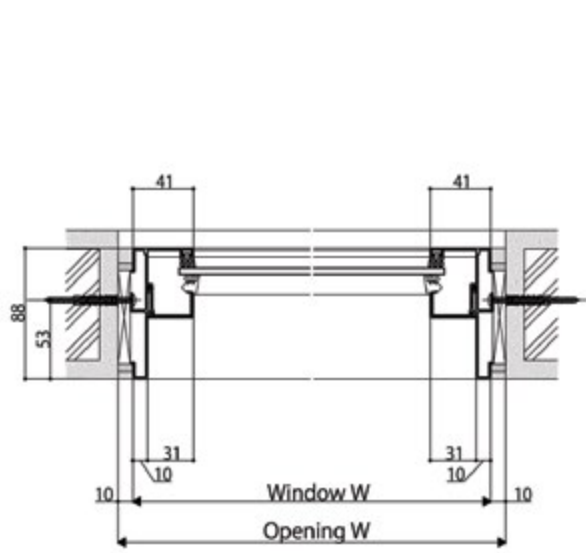

< Horizontal section:  
Single fixed window >

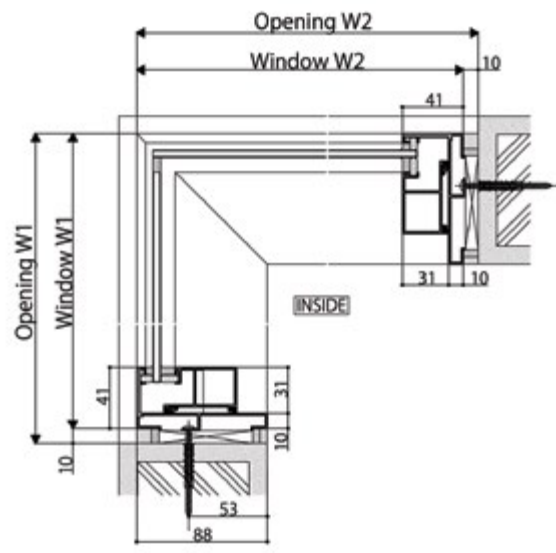

< Horizontal section:  
Outward fixed window >

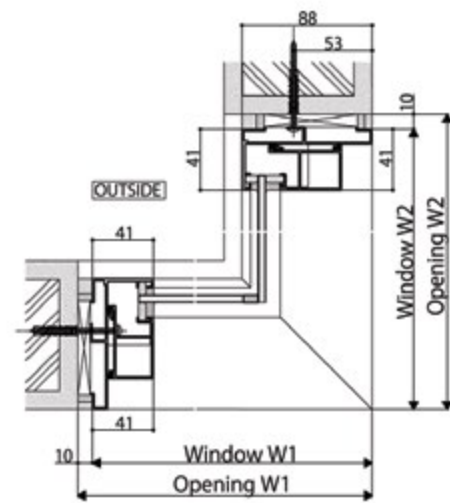

< Horizontal section:  
Inward fixed window >

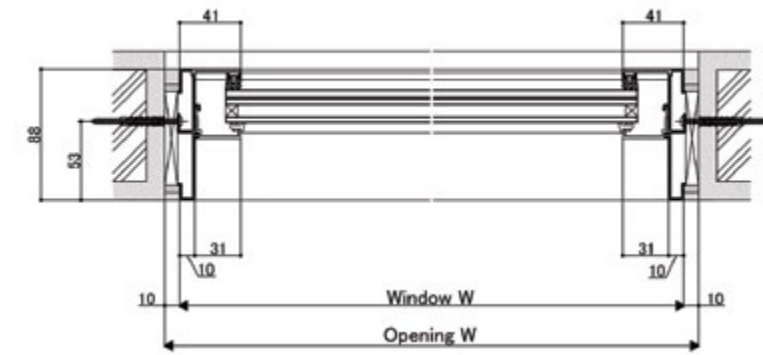

< Horizontal section: Single fixed window (IG unit) >

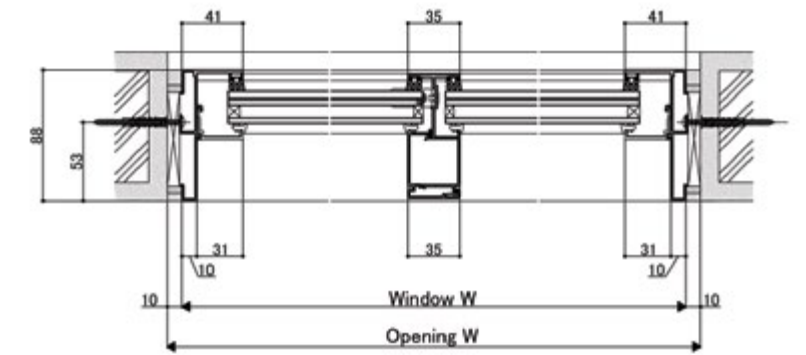

< Horizontal section: Fixed window with mullion (IG unit) >



**ATIS DOOR SERIES**

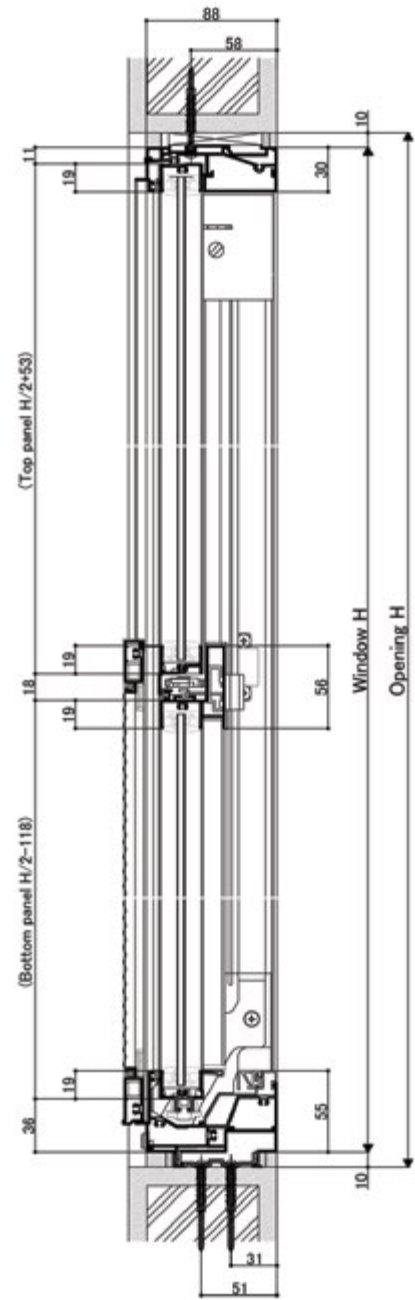

< Vertical section: Tilt & Slide >

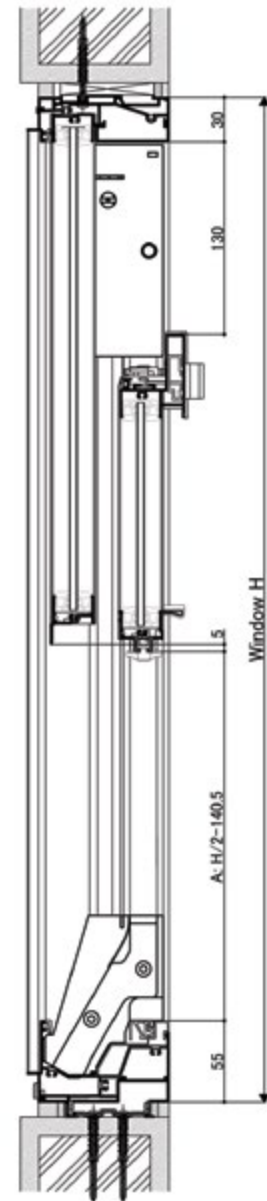

< Vertical section: Tilt & Slide open position >

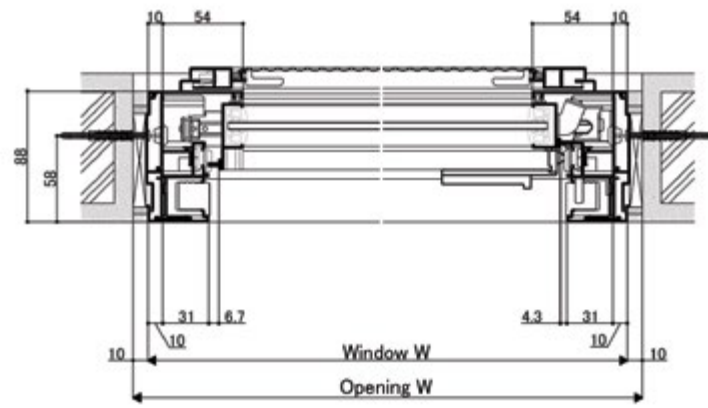

< Horizontal section: Tilt & Slide >



< Horizontal section: Tilt & Slide open position >

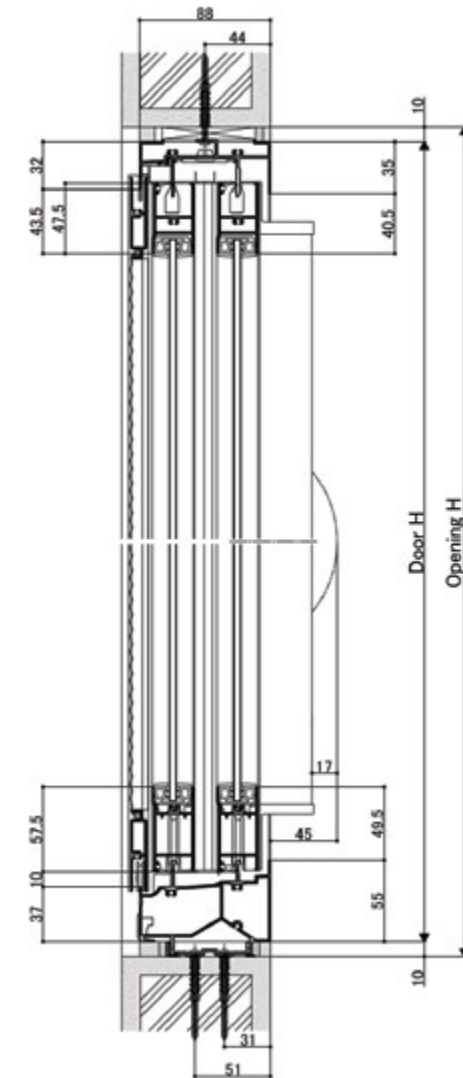

< Vertical section: 2 panels sliding door >

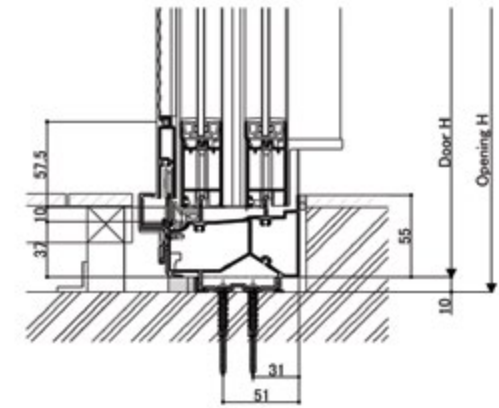

< Vertical section: Barrier flat sill option >

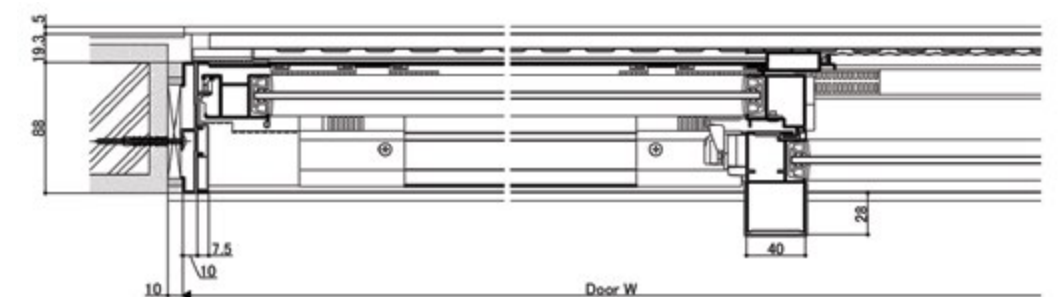

< Horizontal section: Barrier flat sill option >

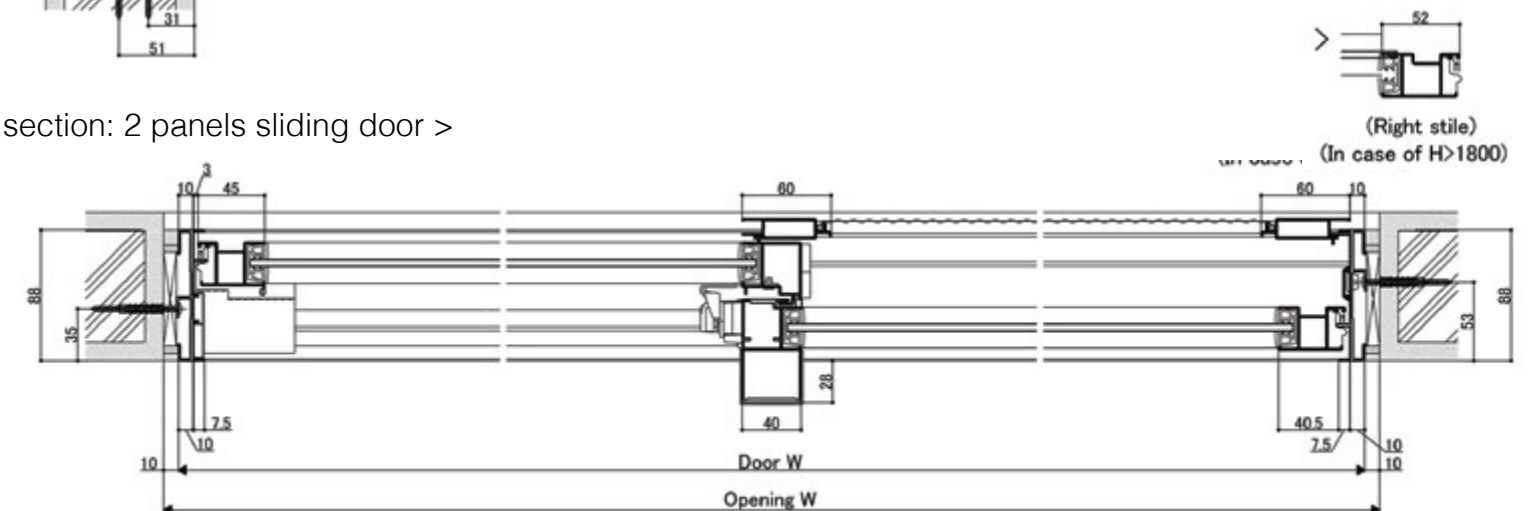

< Horizontal section: 2 panels sliding door >

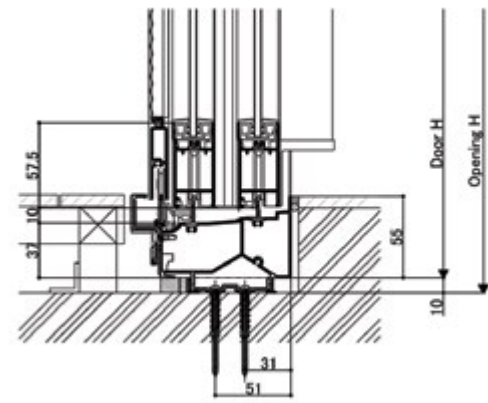
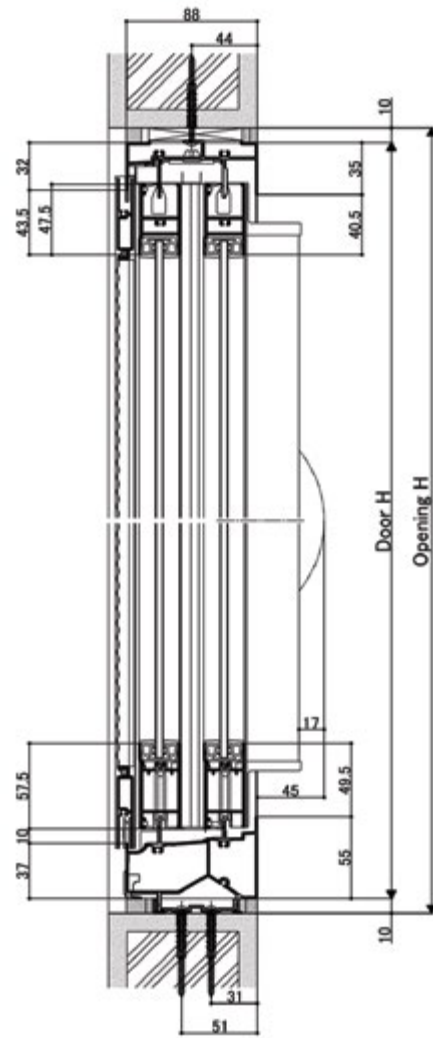

< Vertical section: Barrier flat sill option >

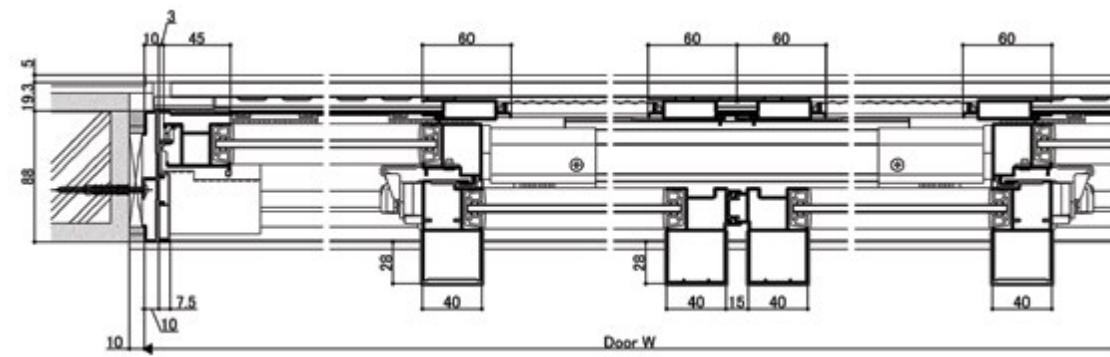

< Horizontal section: Barrier flat sill option >

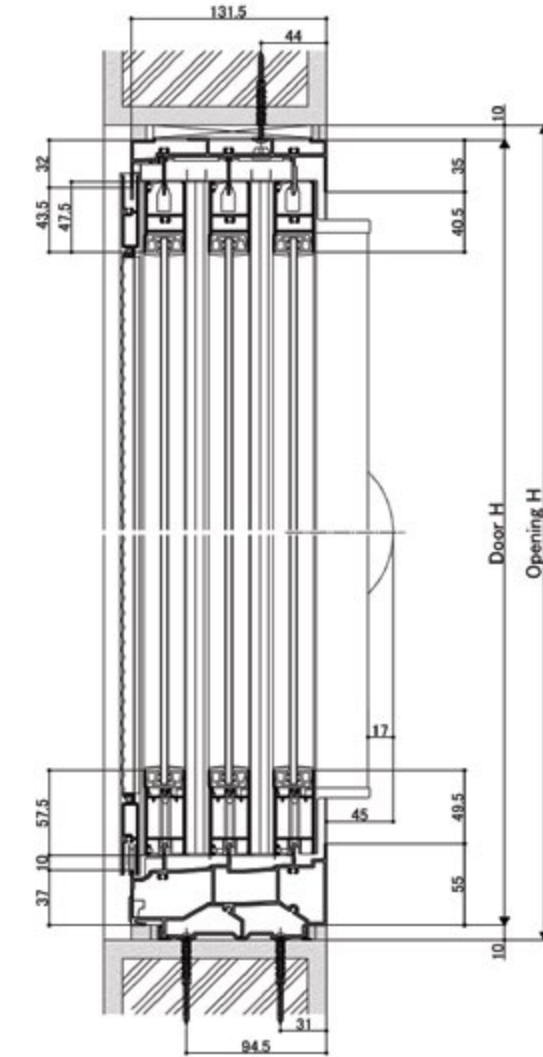

< Vertical section: 3 and 6 panels sliding door >

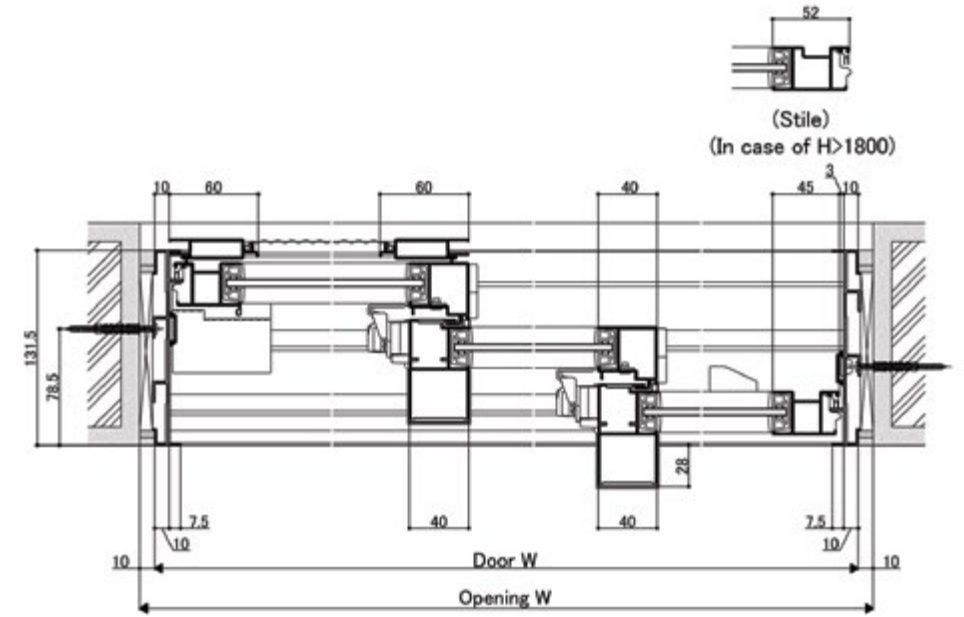

< Horizontal section: 3 panels sliding door >

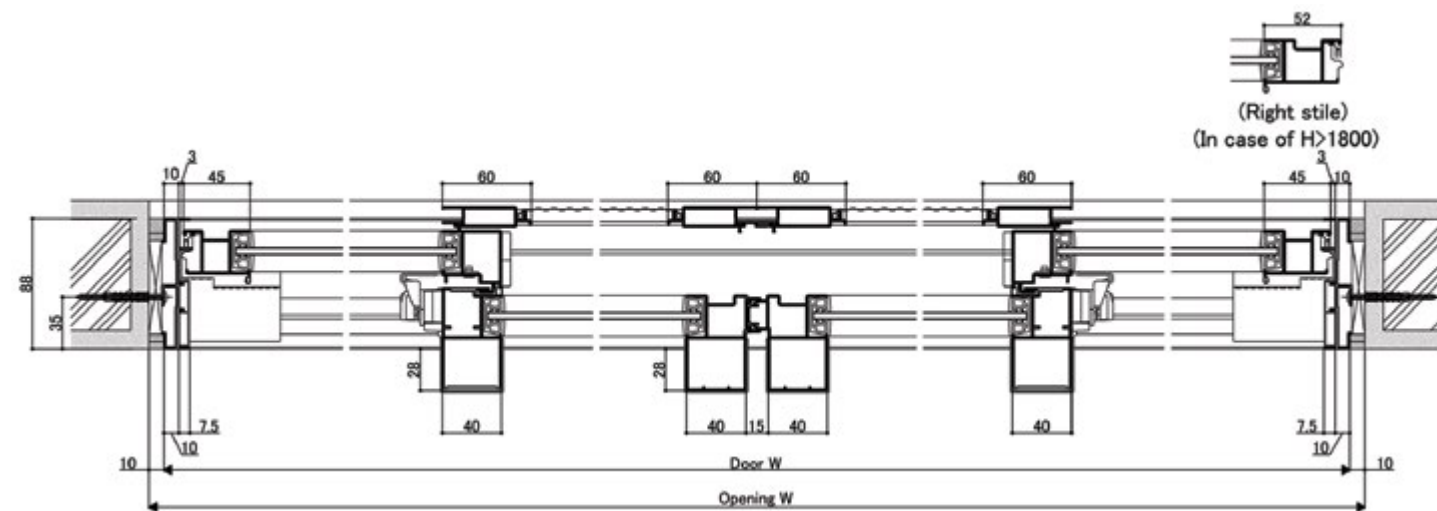

< Horizontal section: 4 panels sliding door >

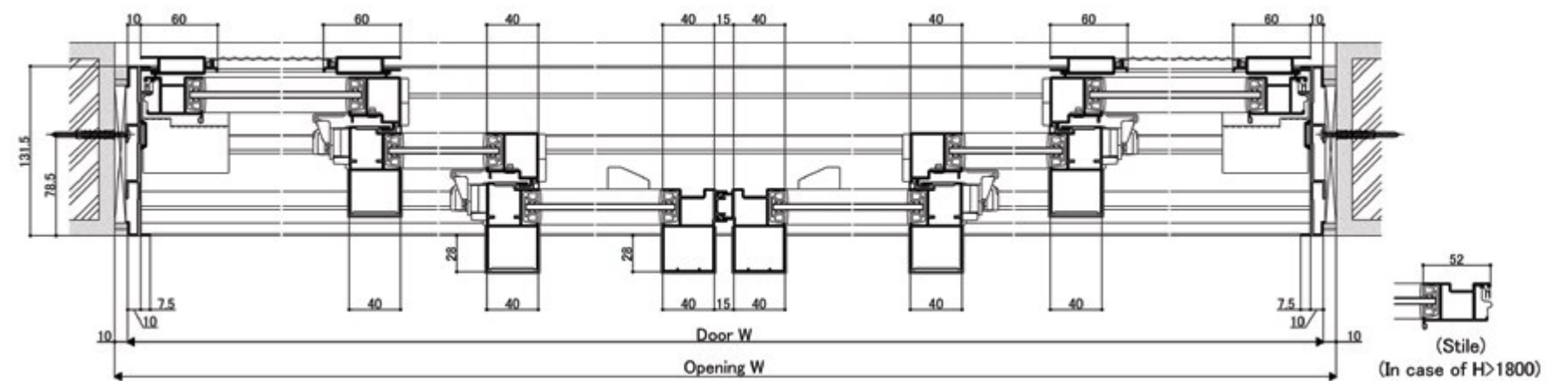

< Horizontal section: 6 panels sliding door >



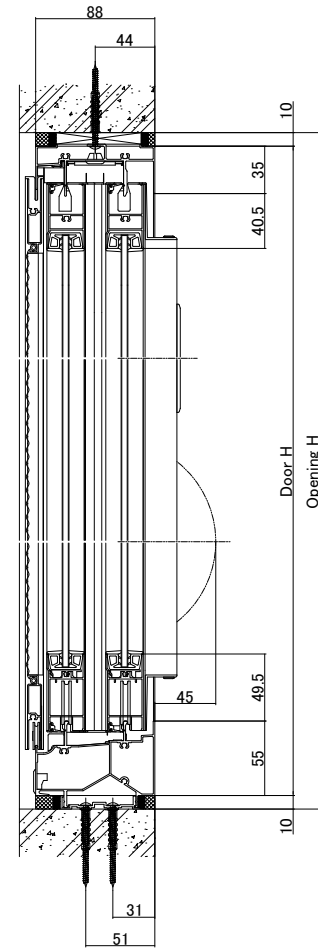

< Vertical section: 2 and 4 panels Entrance Sliding Door >

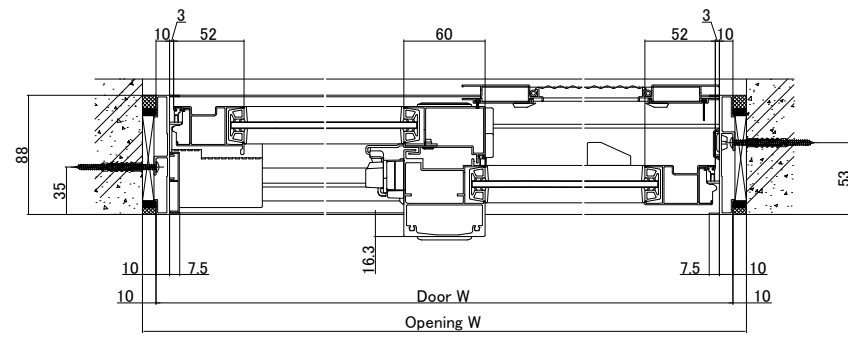

< Horizontal section: 2 panels Entrance Sliding dDoor >

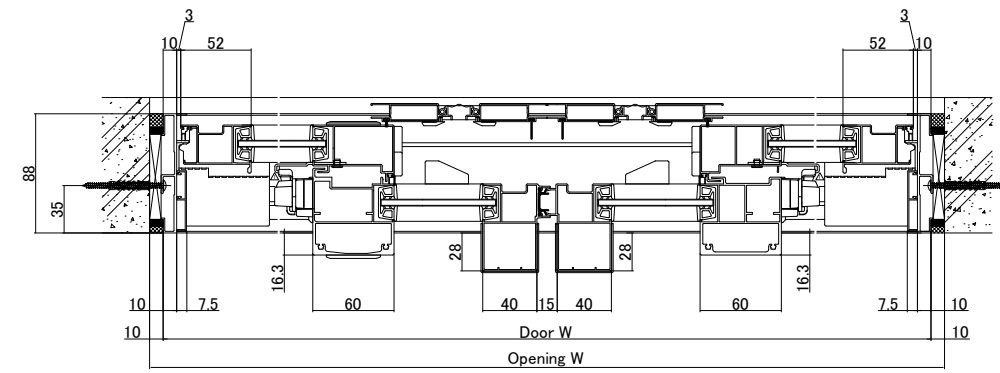

< Horizontal section : 4 panels Entrance Sliding Door >

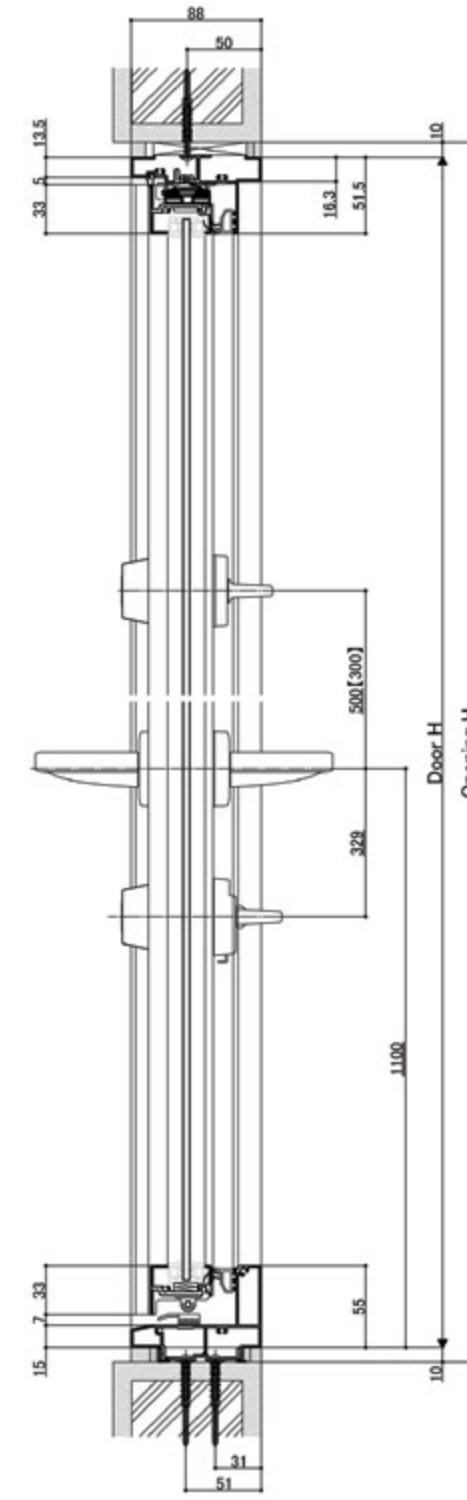

[ ] In case  $H \leq 2000$   
 < Vertical section: Single and double leaf Out-swing door >

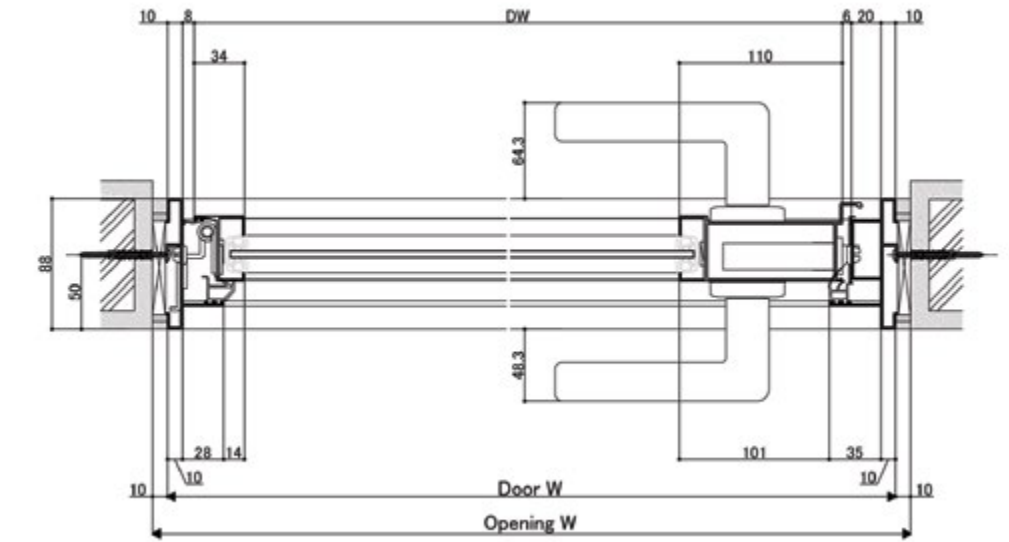

< Horizontal section: Single Out-swing door >

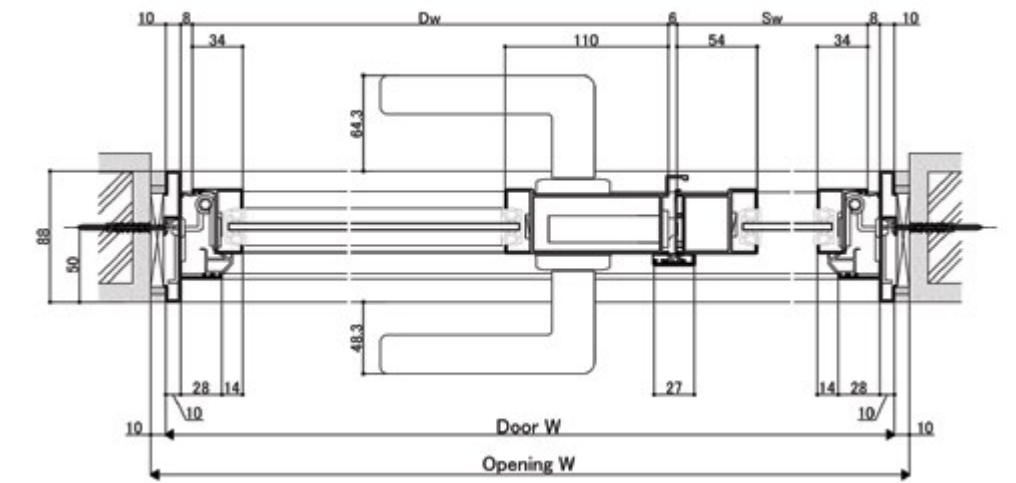

< Horizontal section: Double Out-swing door >

# ATIS COMBINATION

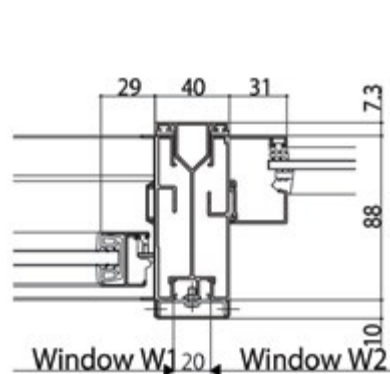

Mullion 180 A Type

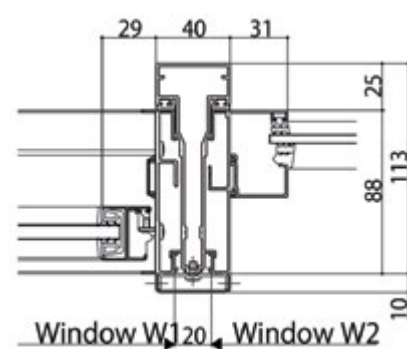

Mullion 180 B Type

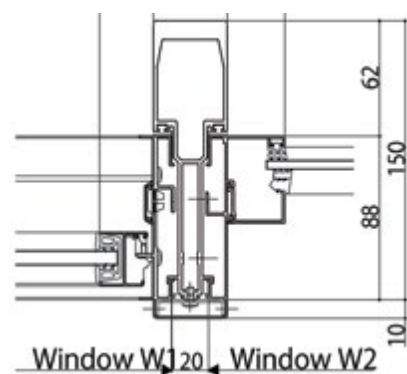

Mullion 180 C Type

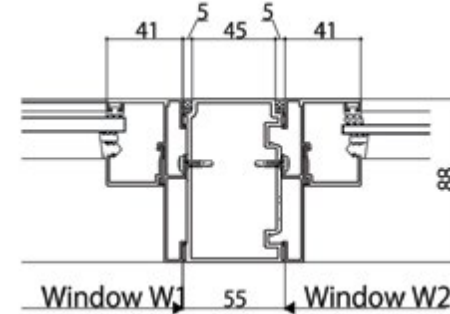

Reinforcement Mullion 180

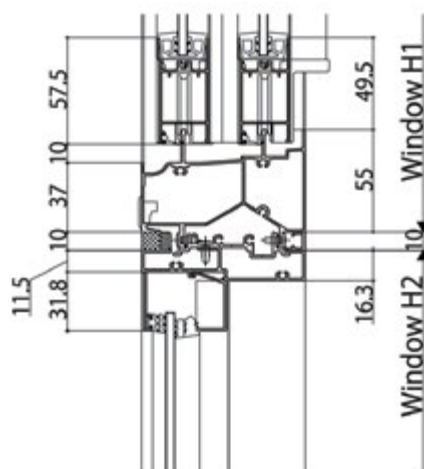

Transom A (88 mm)

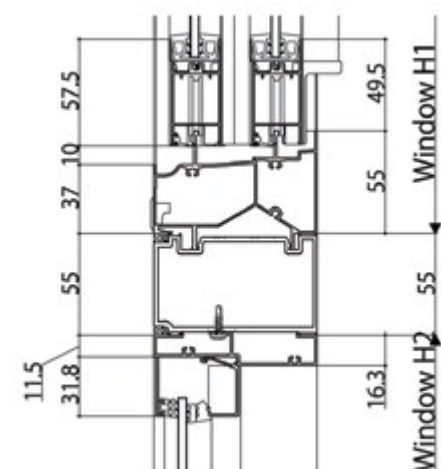

Reinforcement Transom

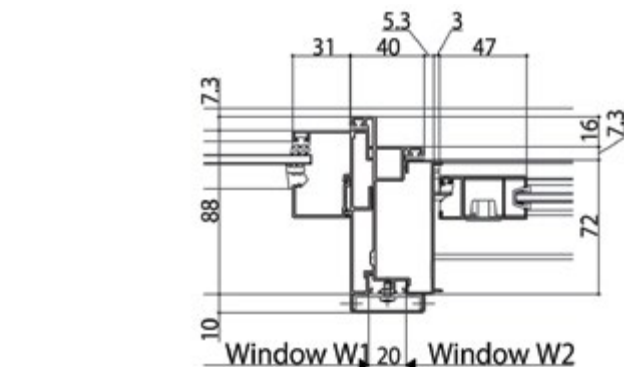

< Horizontal section: Mullion 180 for WE combination >

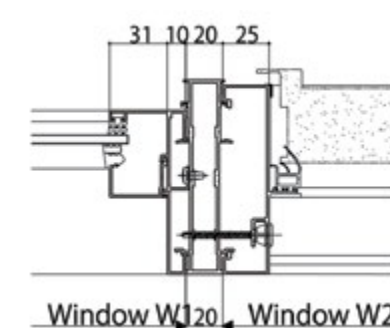

Mullion 180 (101 mm)

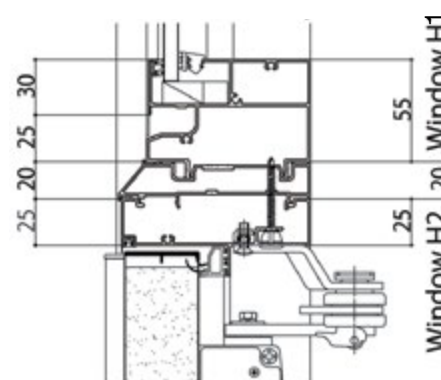

Transom (101 mm)

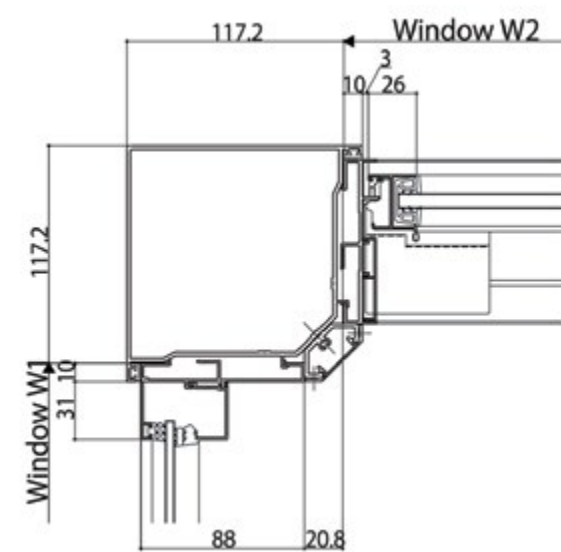

< Horizontal section: Mullion 90 combination >

< Horizontal section: Mullion 180 & Vertical section Transom for Giesta combination >

# WE 70 WINDOW SERIES

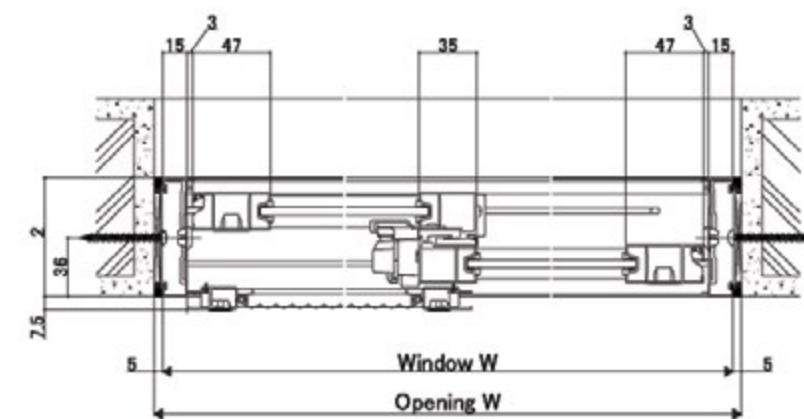

< Horizontal section: 2 panels sliding window >

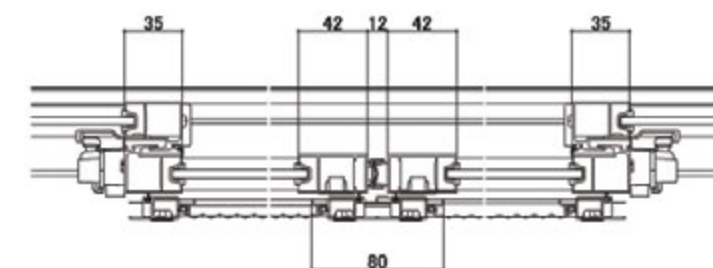

< Horizontal section: 4 panels sliding window >

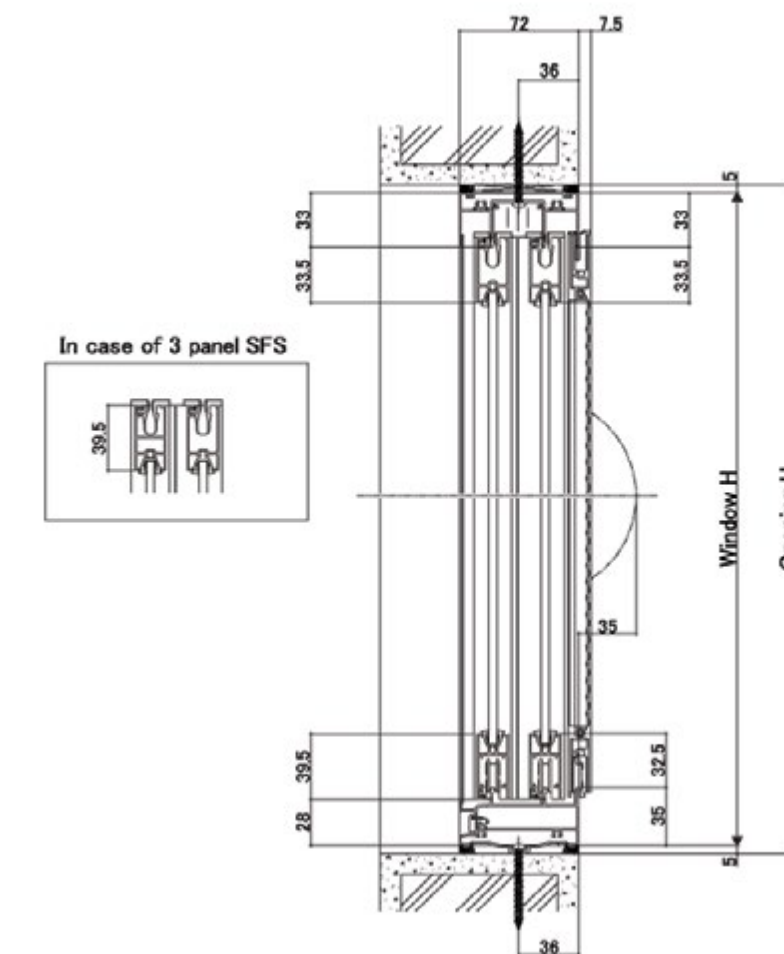

< Vertical section: 2, 4 and SFS 3 panels sliding window >

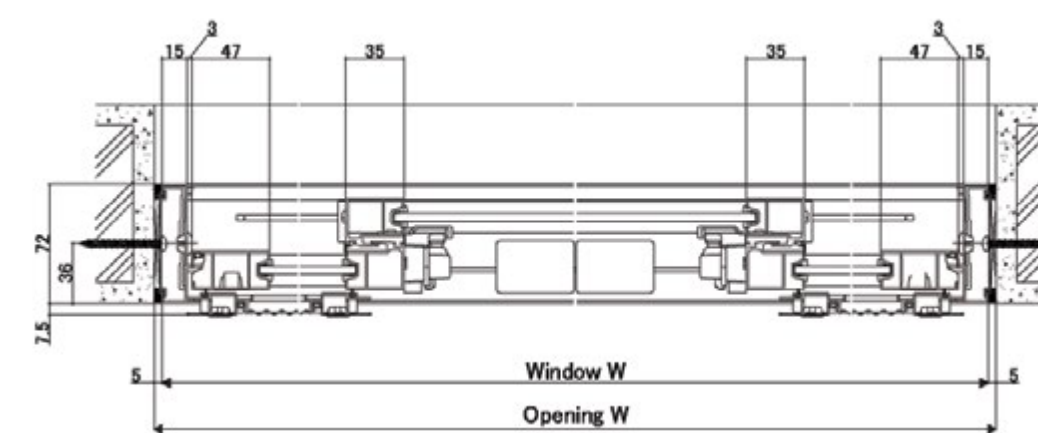

< Horizontal section: SFS 3 panels sliding window >



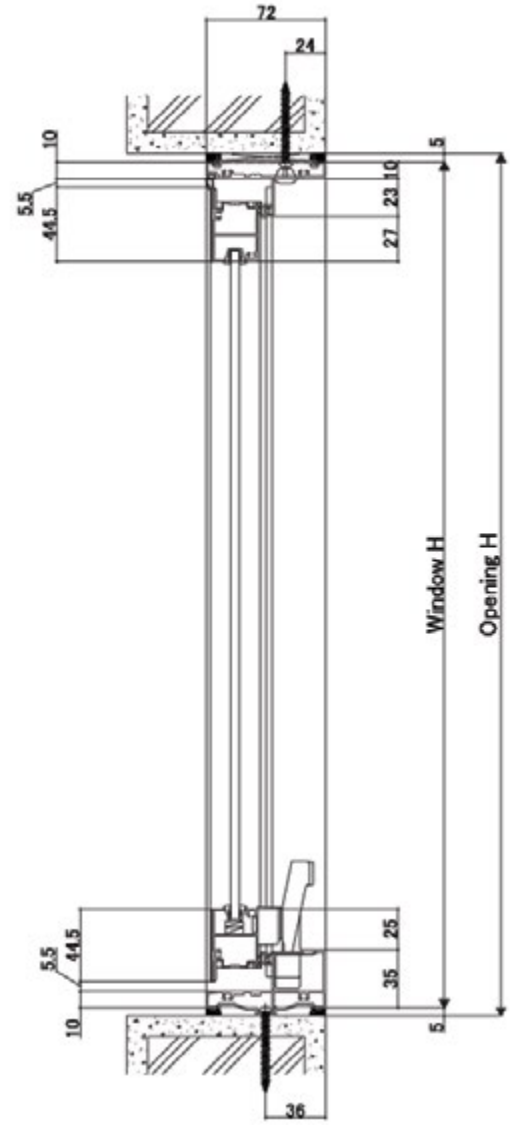

< Vertical section: Awning window >

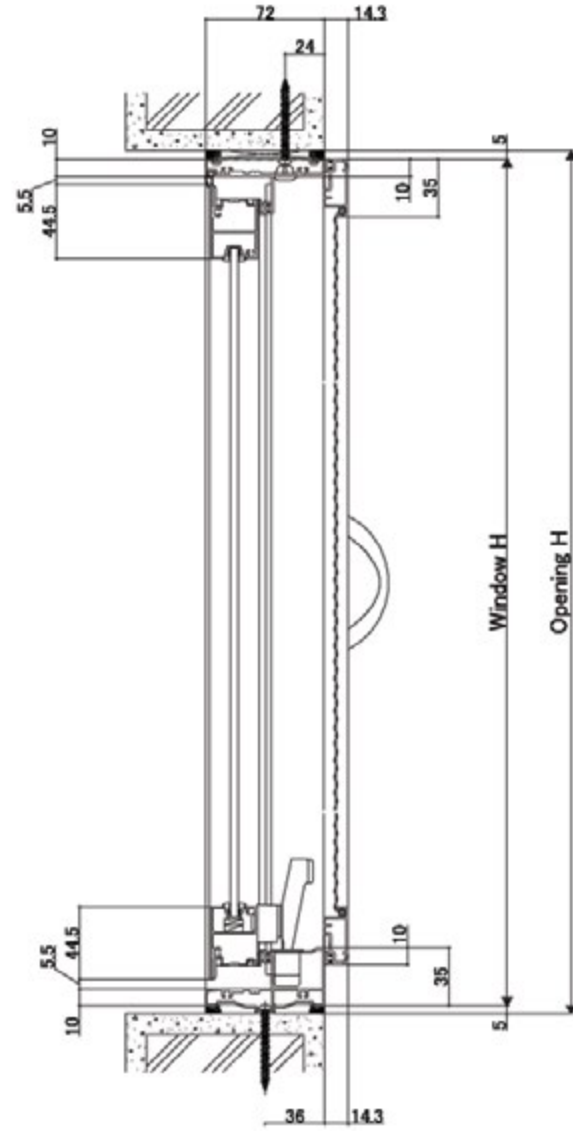

< Vertical section: Awning with screen >

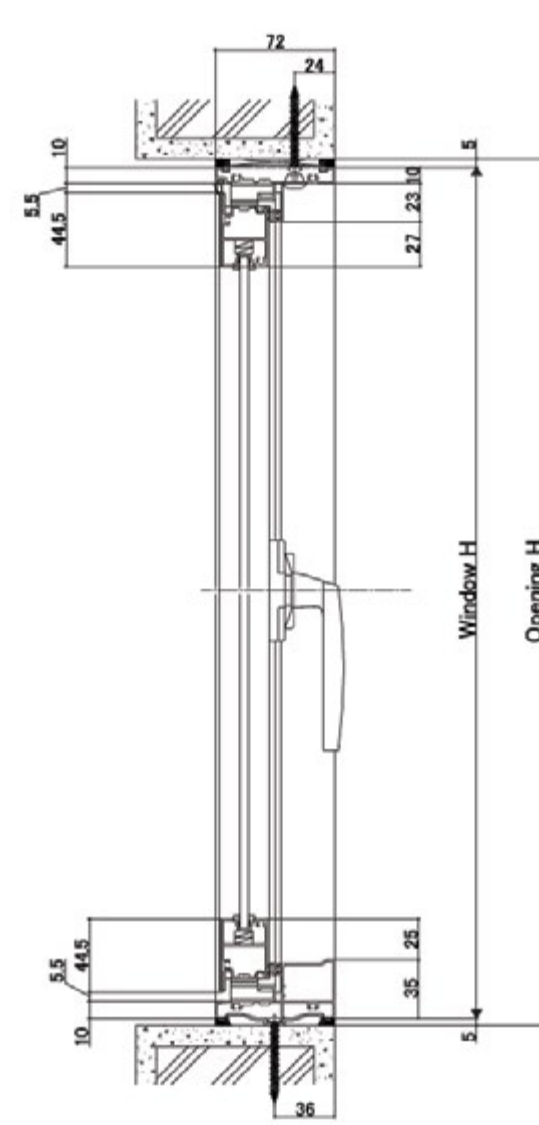

< Vertical section: Casement window >

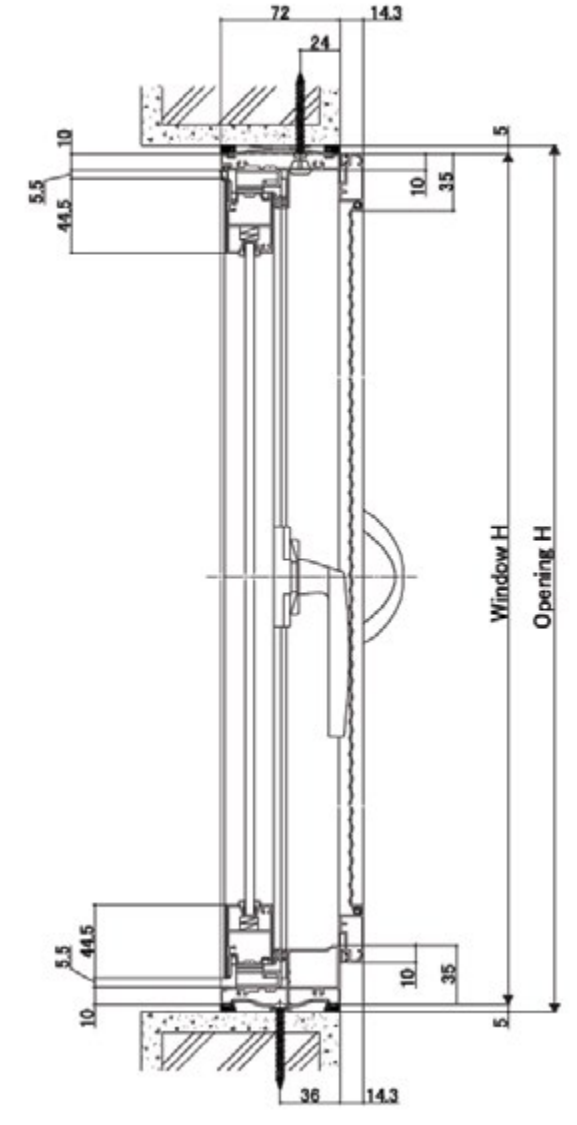

< Vertical section: Casement with screen >

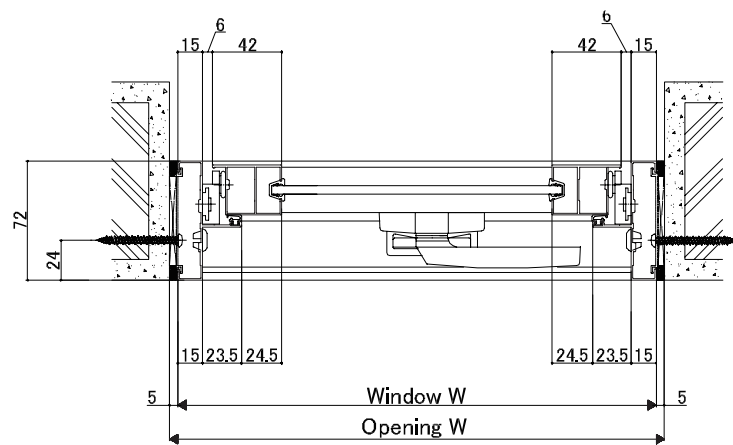

< Horizontal section: Awning window >

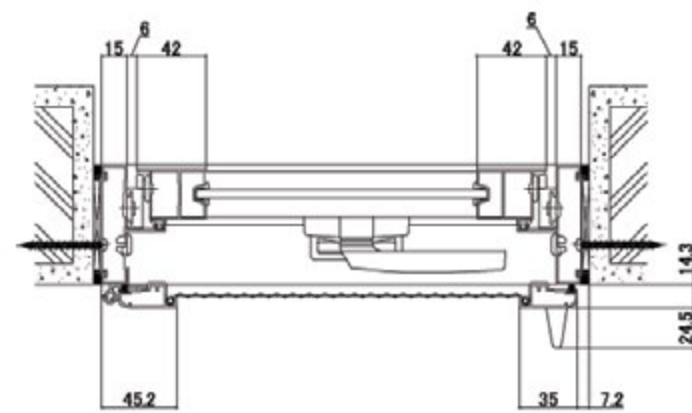

< Horizontal section: Awning with screen >

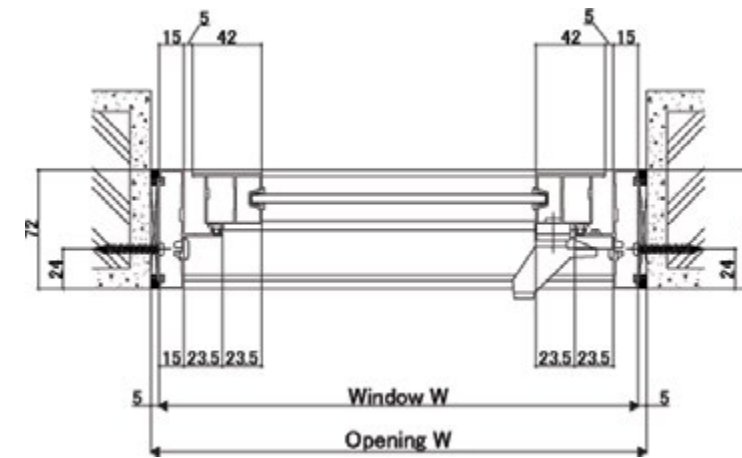

< Horizontal section: Casement window >

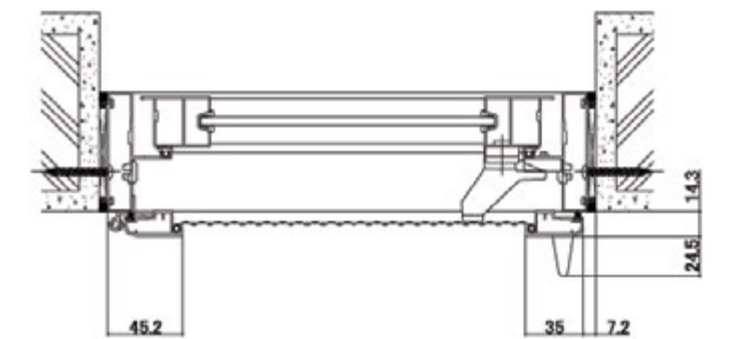

< Horizontal section: Casement with screen >

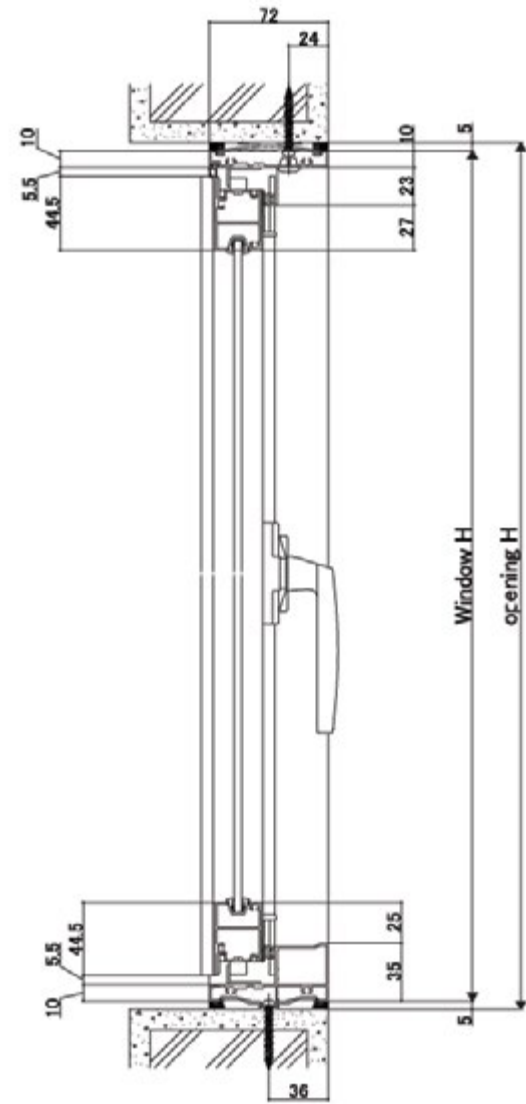

< Vertical section: Double casement window >

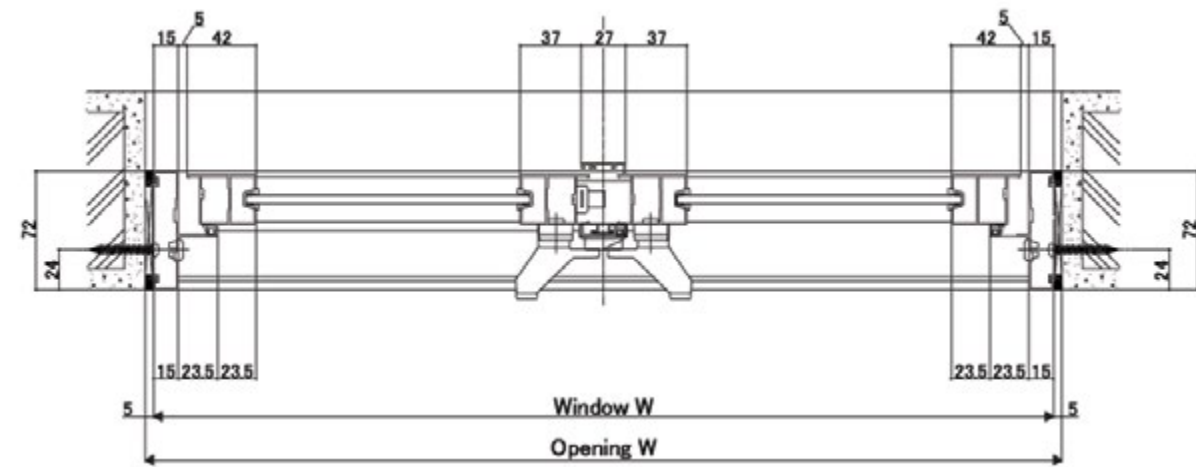

< Horizontal section: Double casement window >

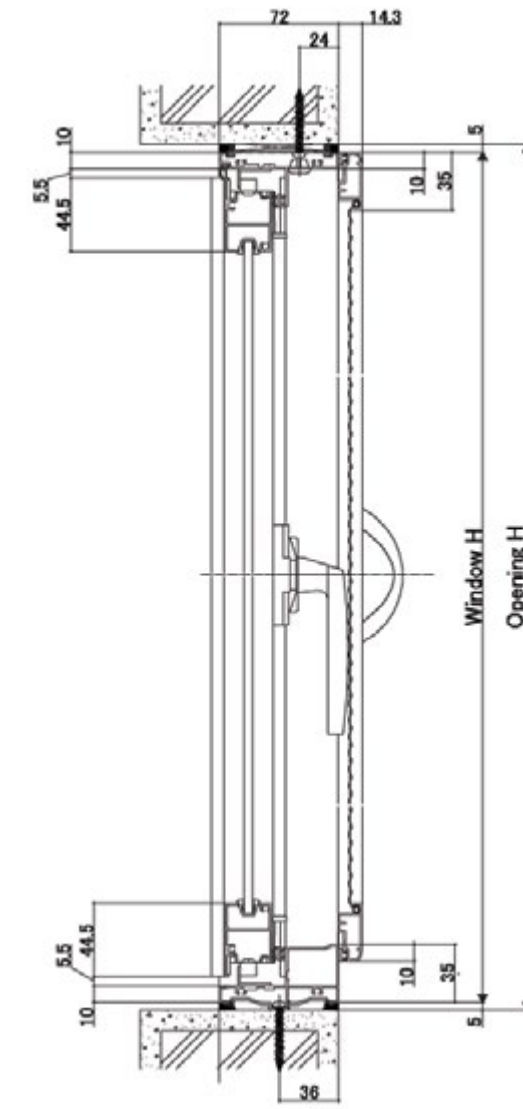

< Vertical section: Double Casement with screen >

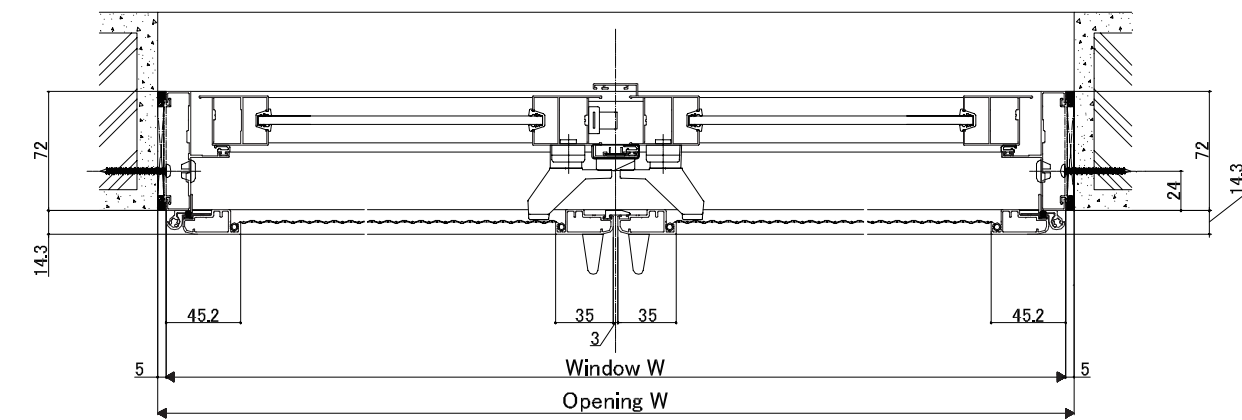

< Horizontal section: Double Casement with screen >



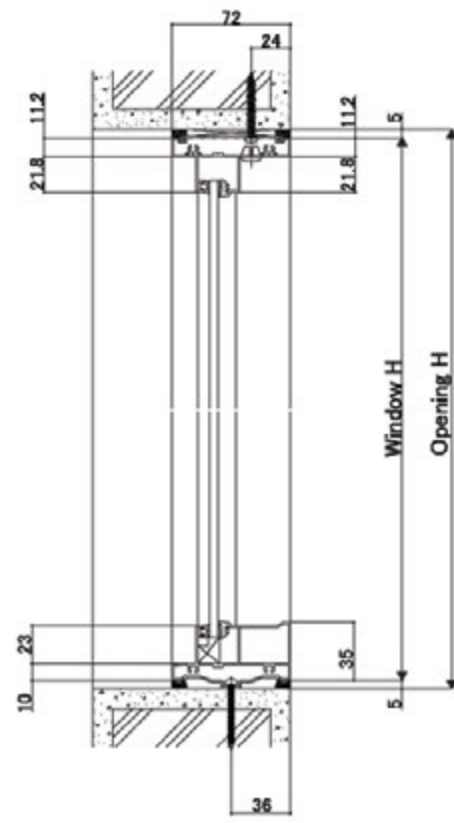

< Vertical section: Single and corner fixed window >

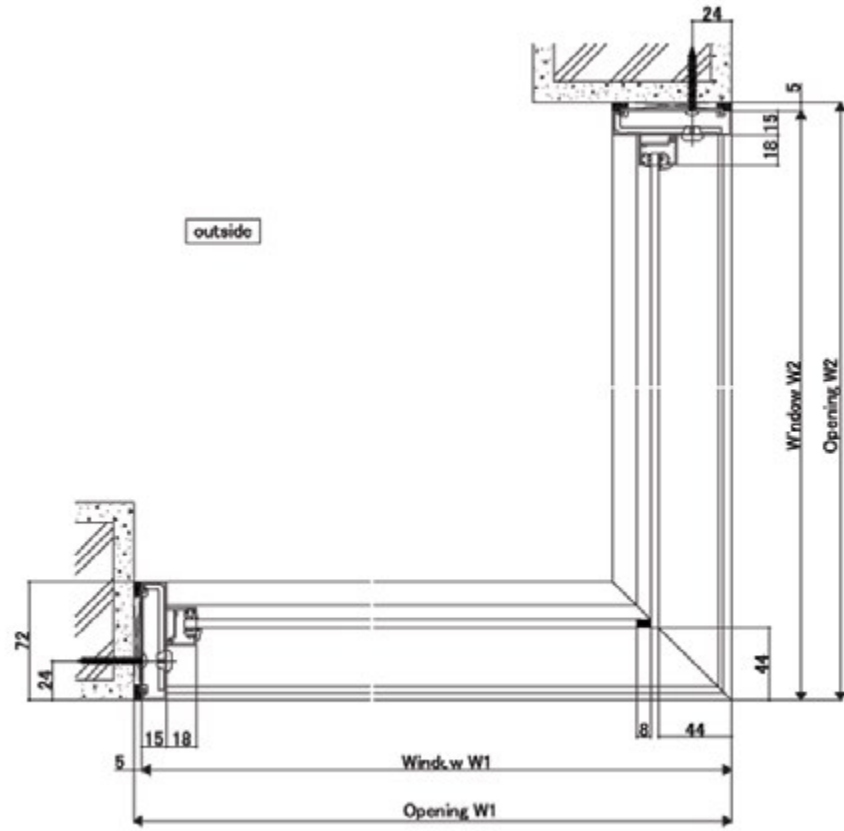

< Horizontal section: Inward fixed window >

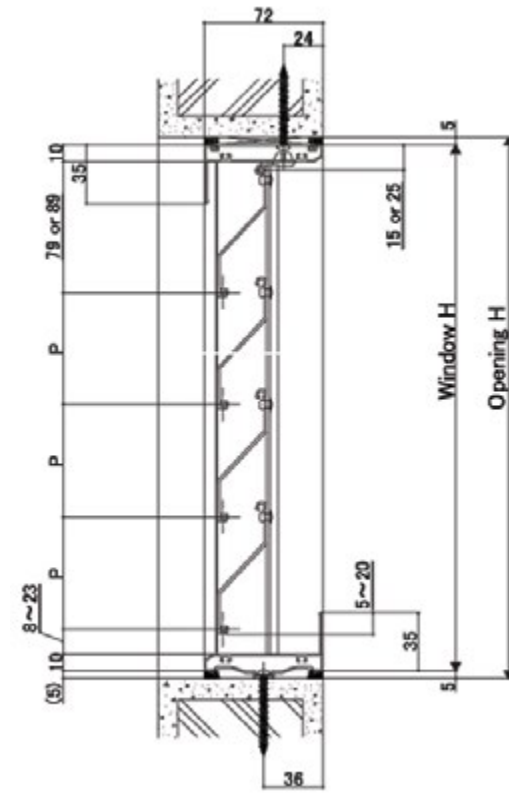

< Vertical section: Aluminum louver >

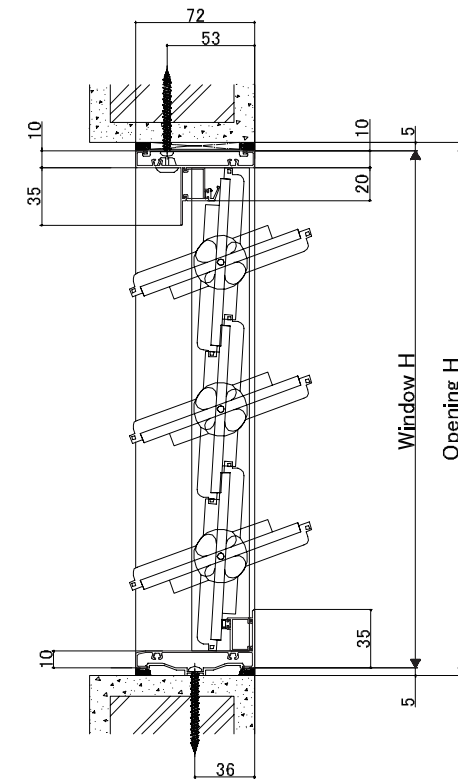

< Vertical section: Glass louver >

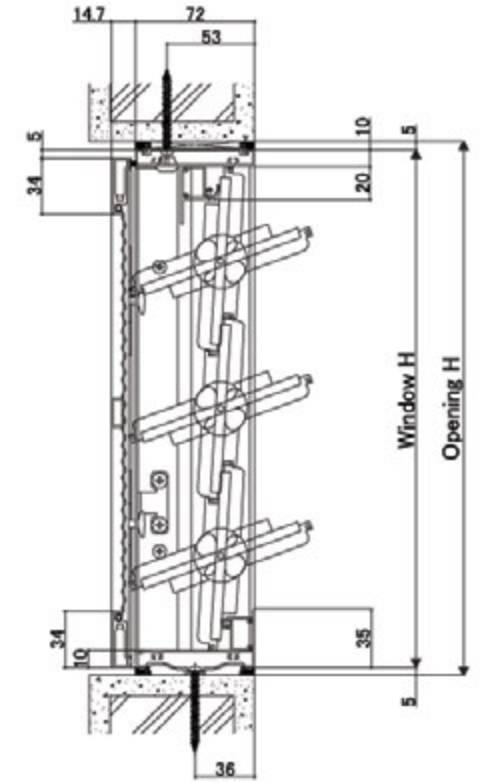

< Vertical section: Glass louver >  
(with screen)

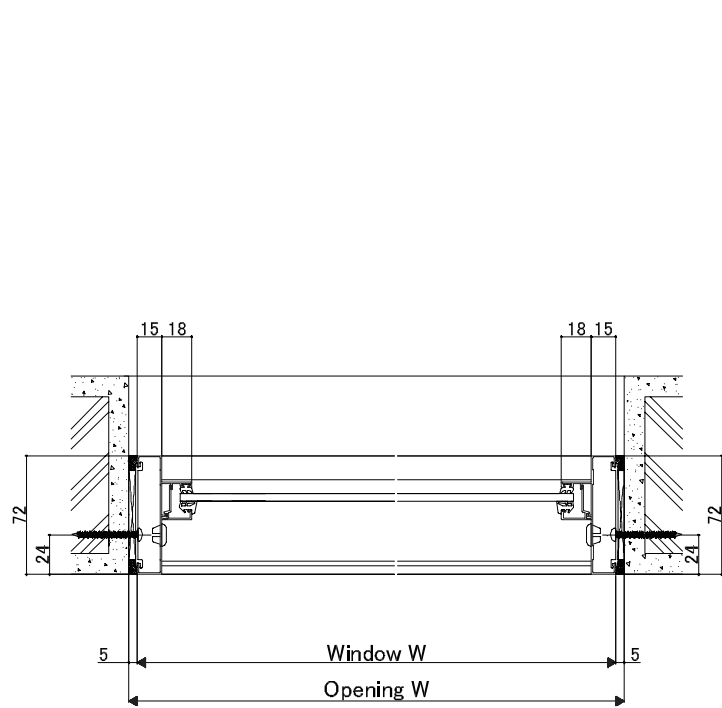

< Horizontal section: Single fixed window >

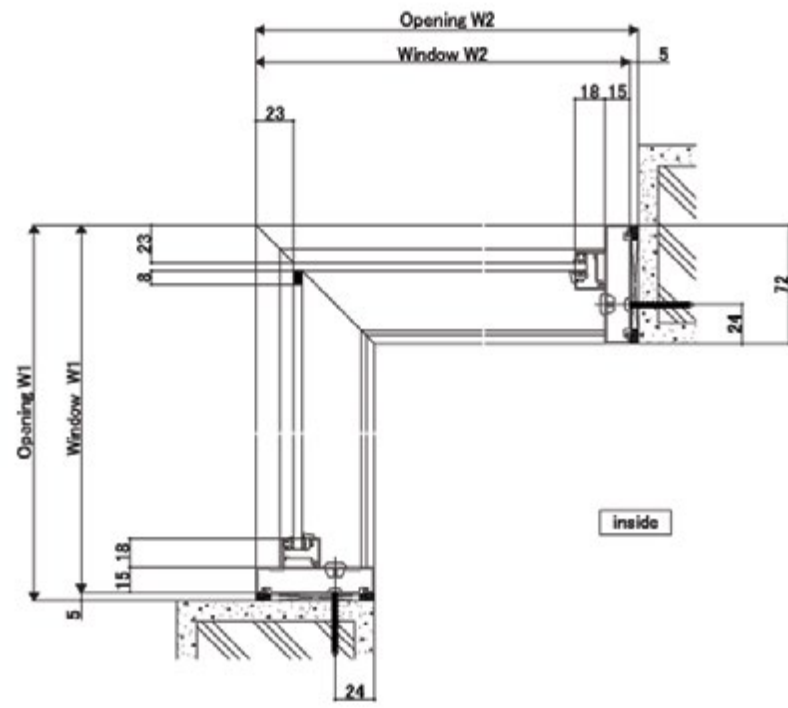

< Horizontal section: Outward fixed window >

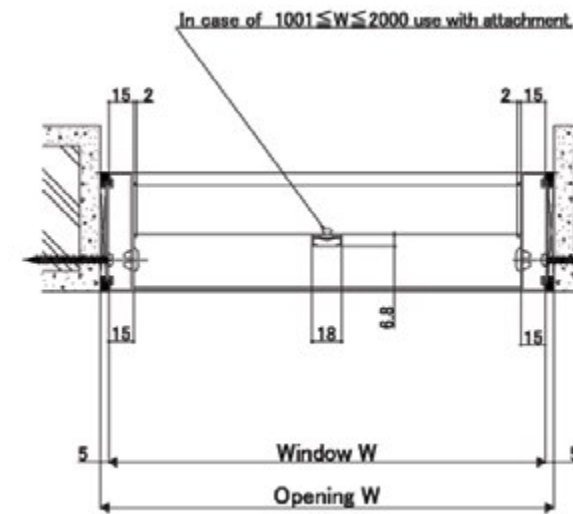

< Horizontal section: Aluminum louver >

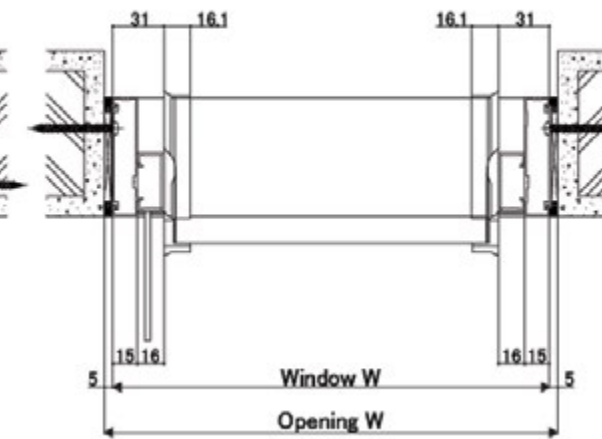

< Horizontal section: Glass louver >

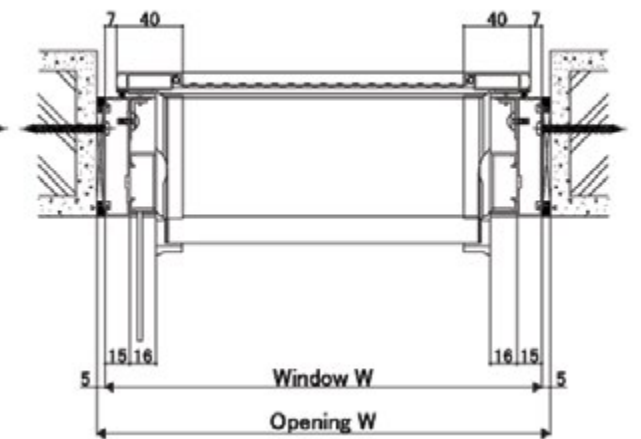

< Horizontal section: Glass louver >  
(with screen)

**WE 70 AIRFLOW SLOT**

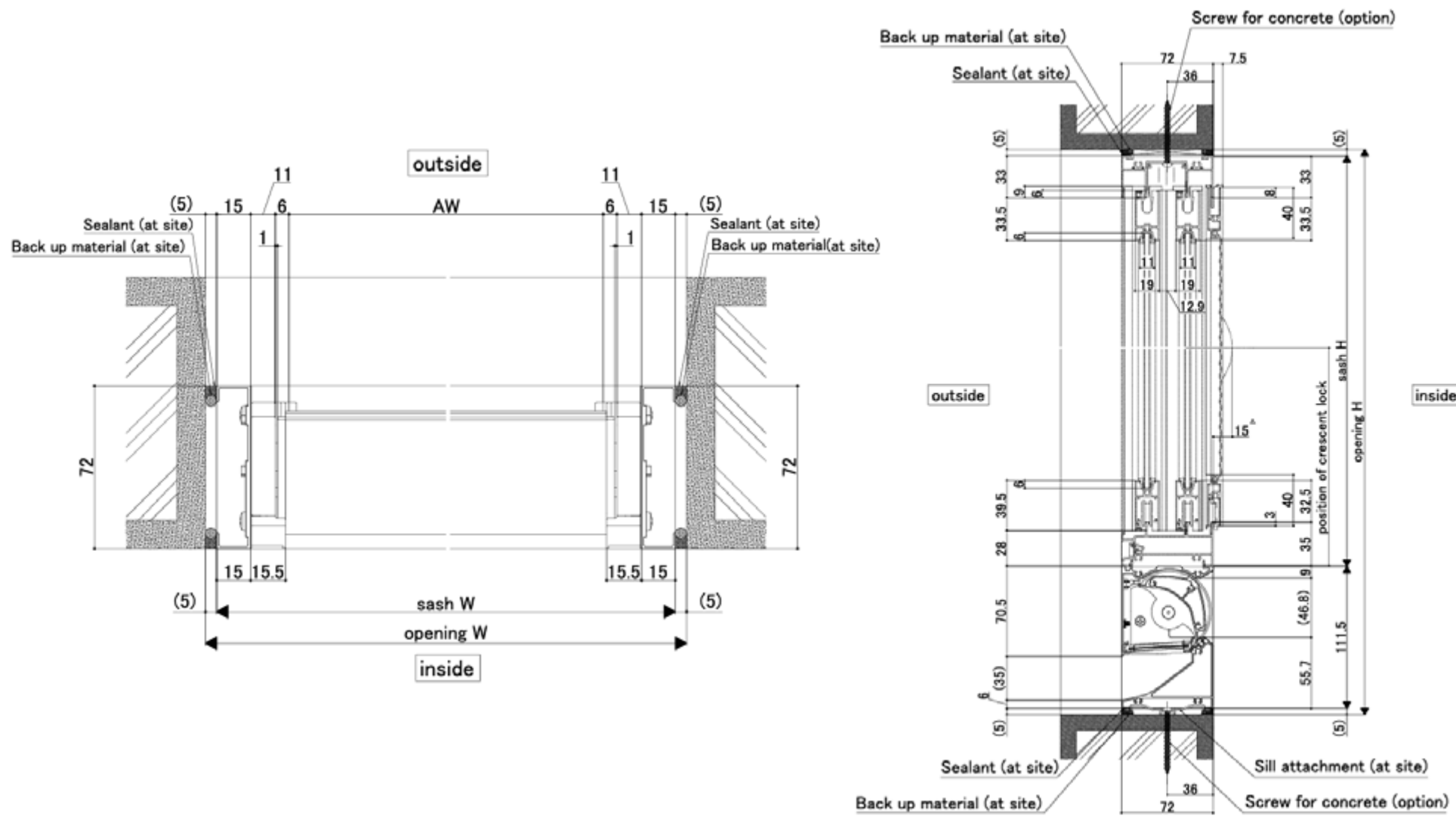

**WE 70 DOOR SERIES**

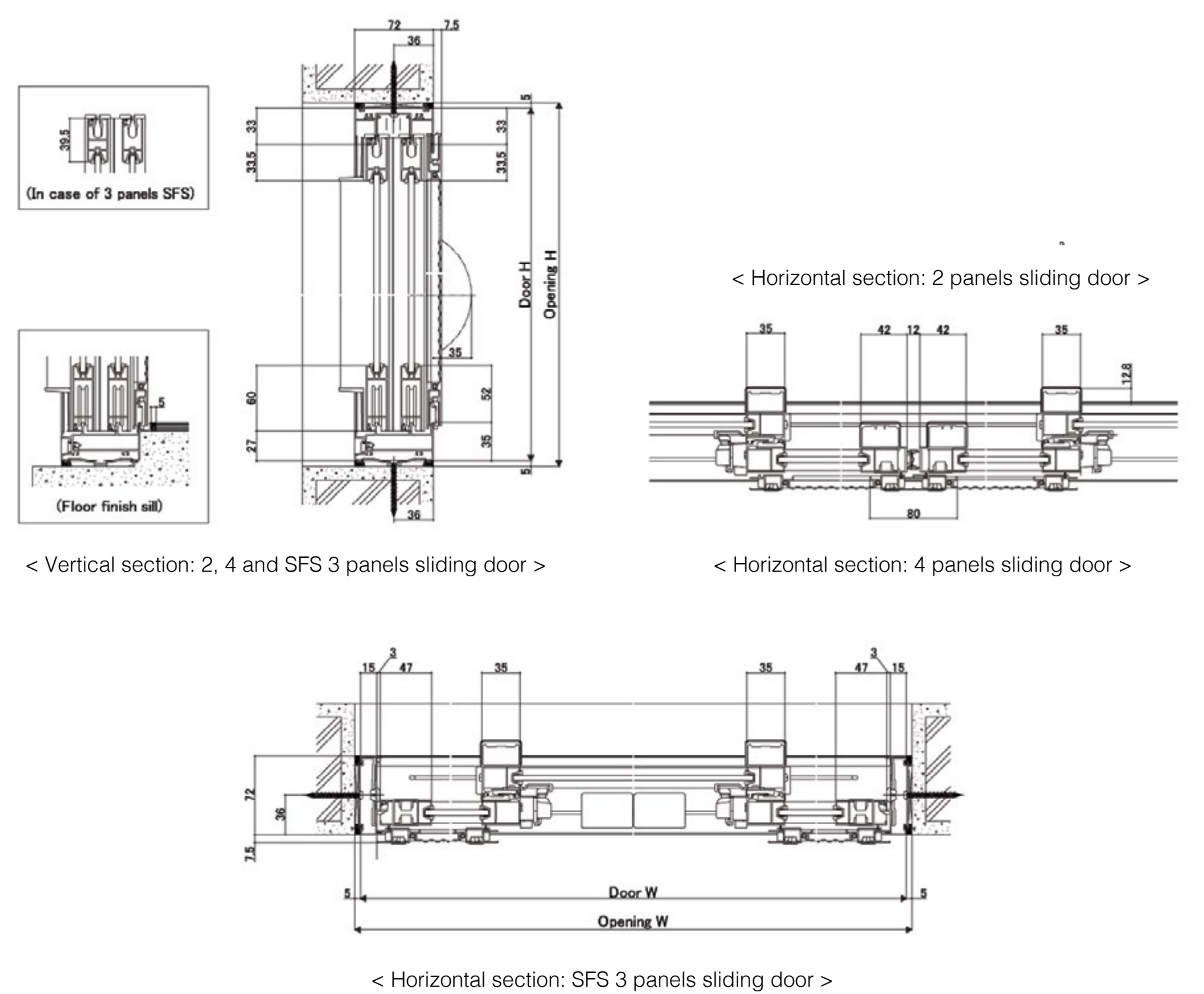



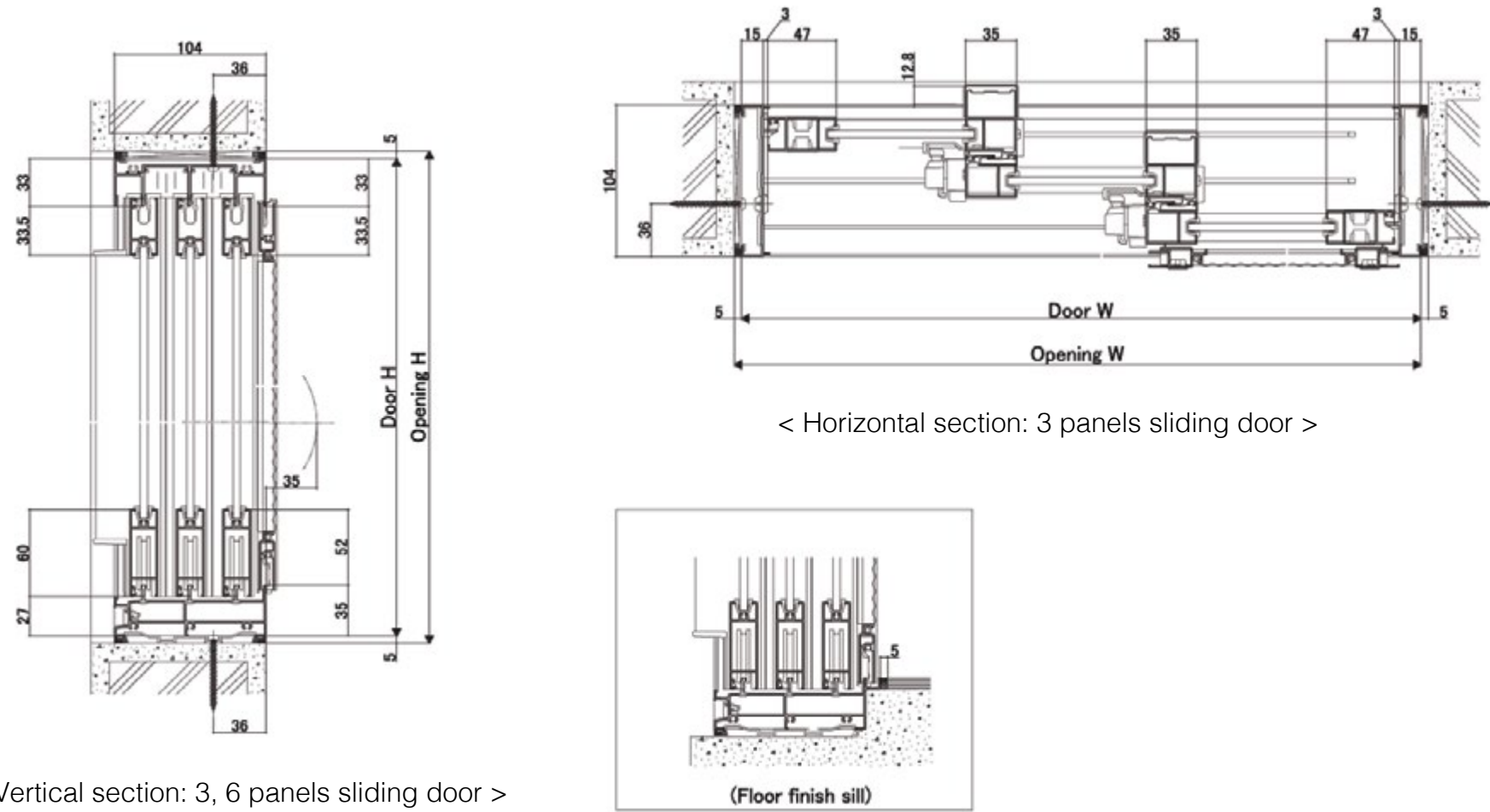

< Horizontal section: 3 panels sliding door >

< Vertical section: 3, 6 panels sliding door >

(Floor finish sill)

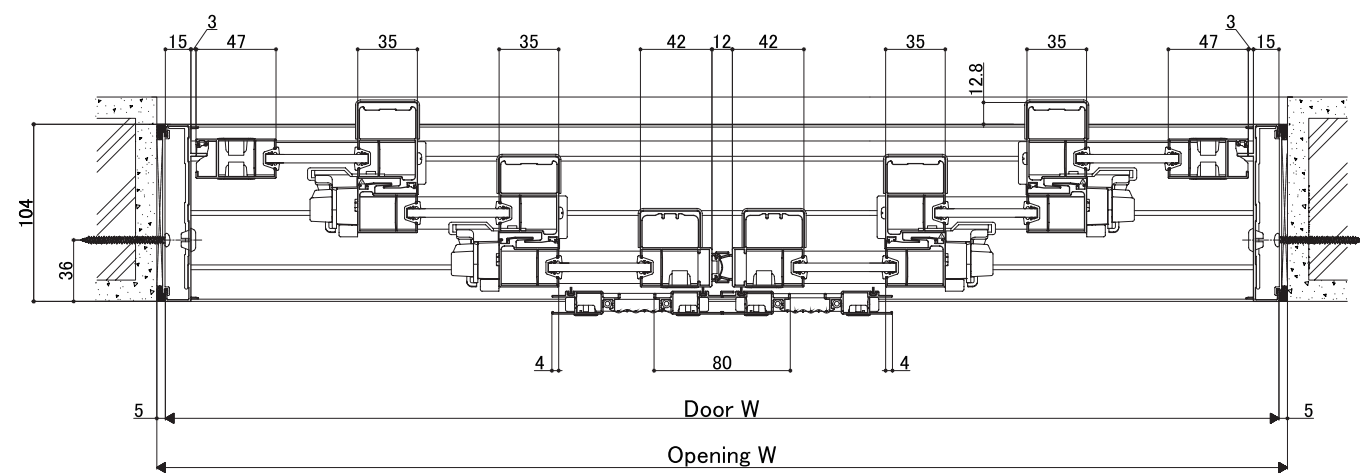

< Horizontal section: 6 panels sliding door >

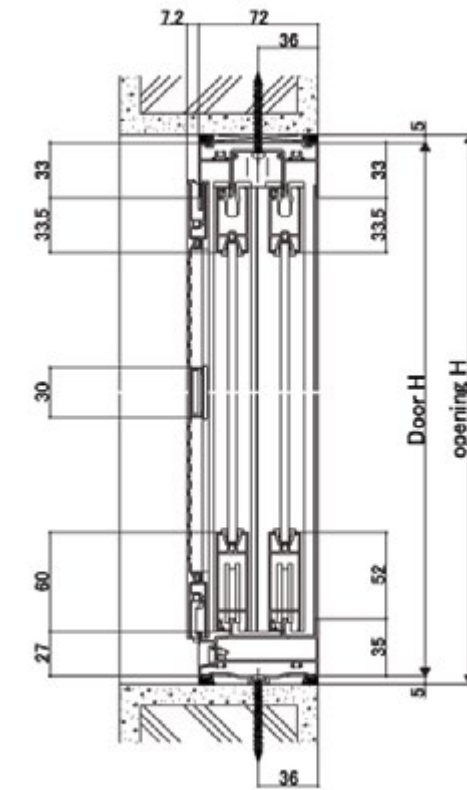

< Vertical section: 2 and 4 panels sliding door >

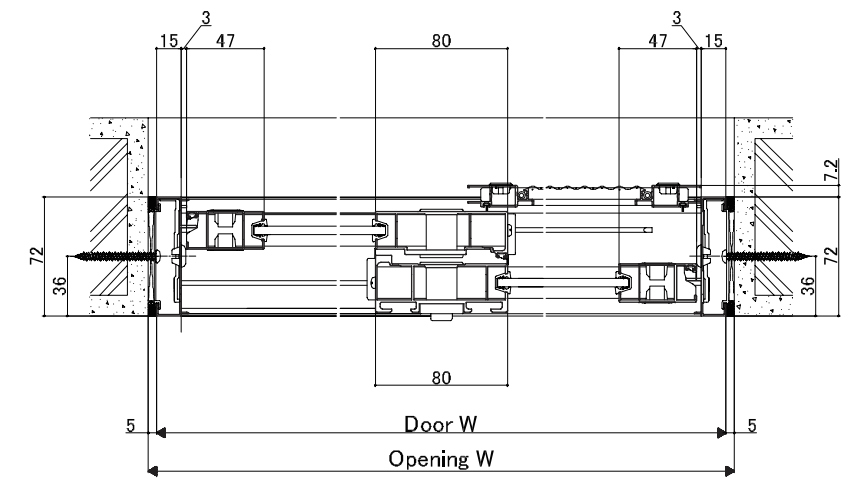

< Horizontal section: 2 panels panel sliding door >

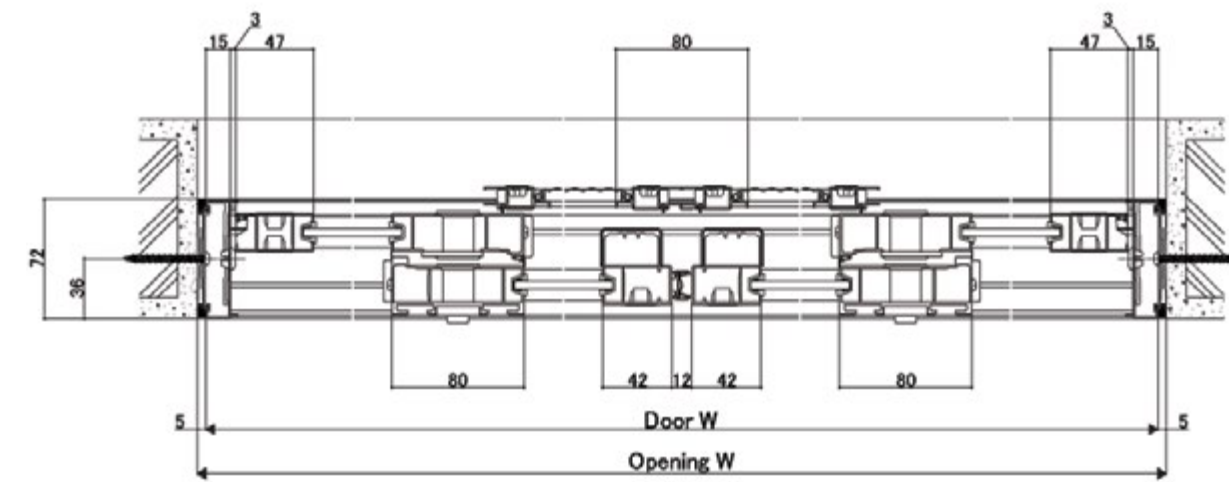

< Horizontal section: 4 panels sliding door >

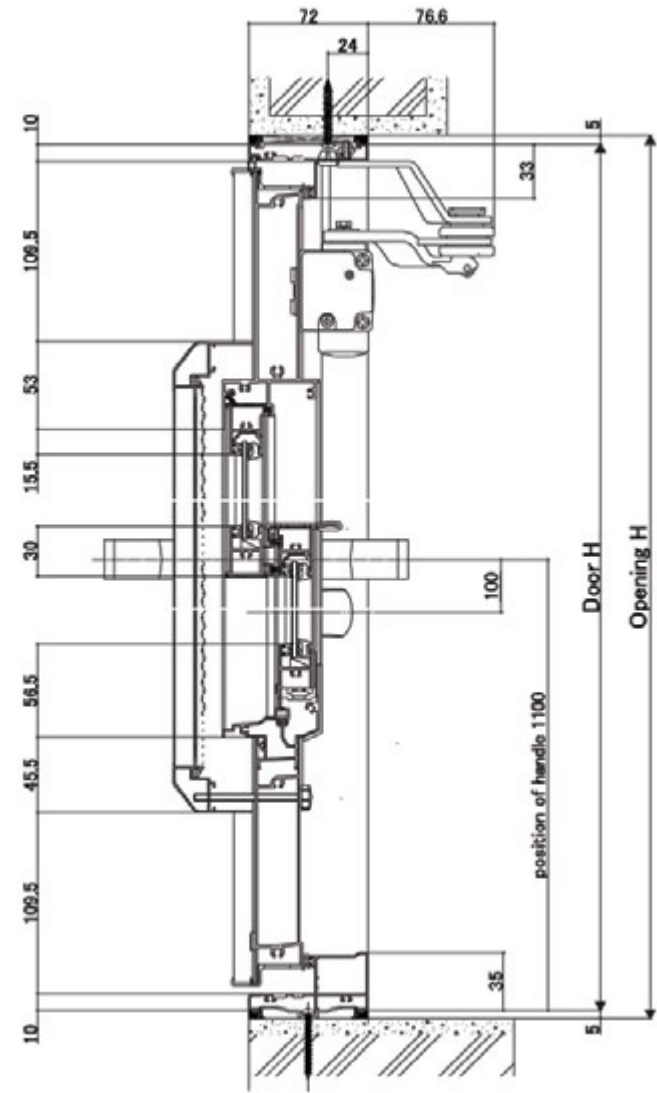

< Vertical section: AIRFLOW Door >

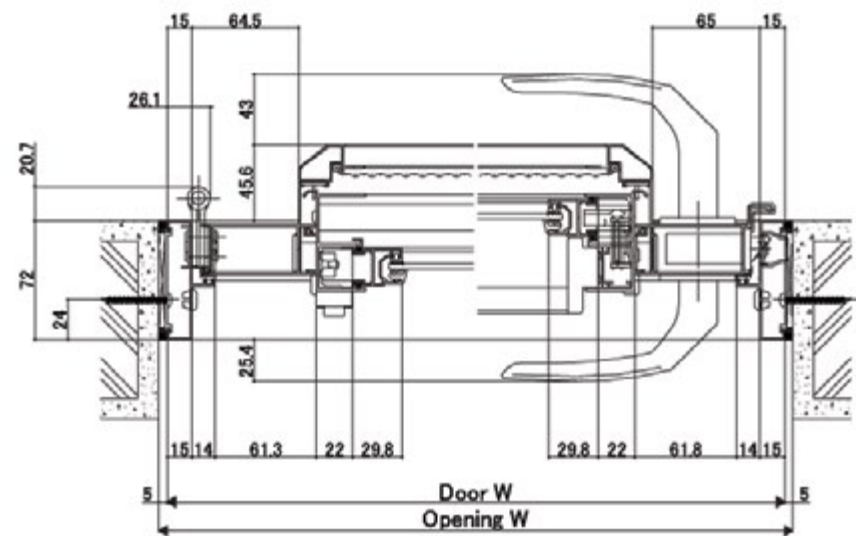

< Horizontal section: AIRFLOW Door >

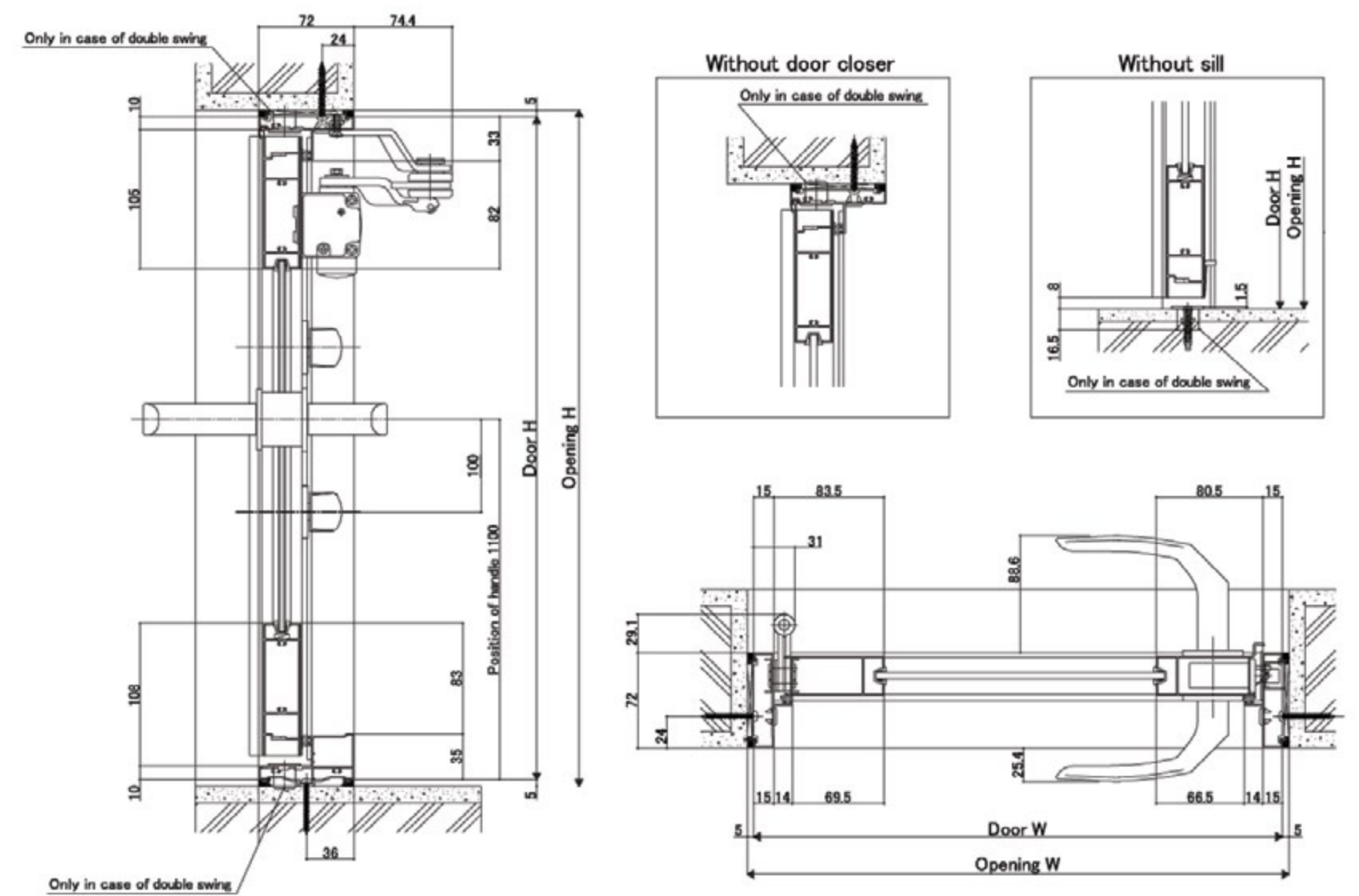

< Vertical section: Single & double out-swing door with sill >

< Horizontal section: Single out-swing door >

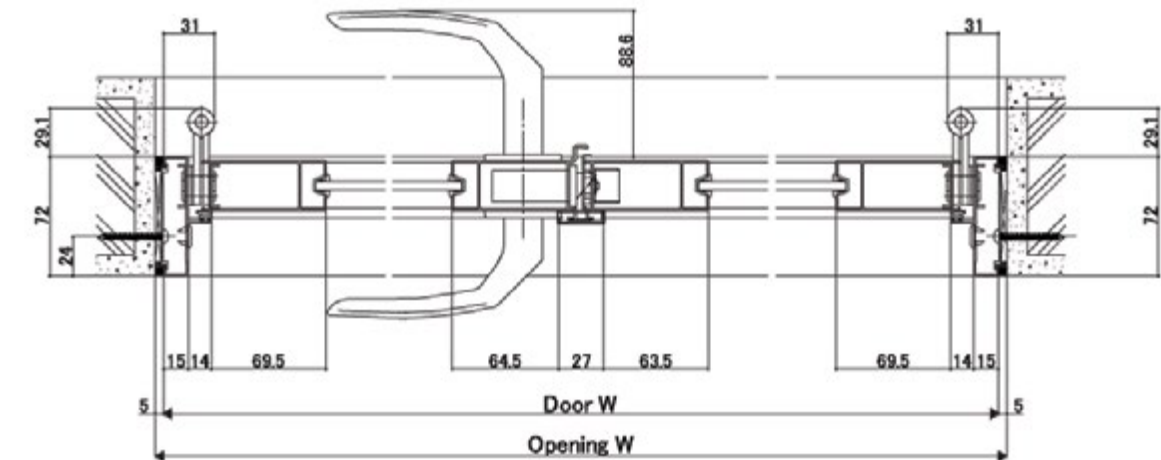

< Horizontal section: Double out-swing door >



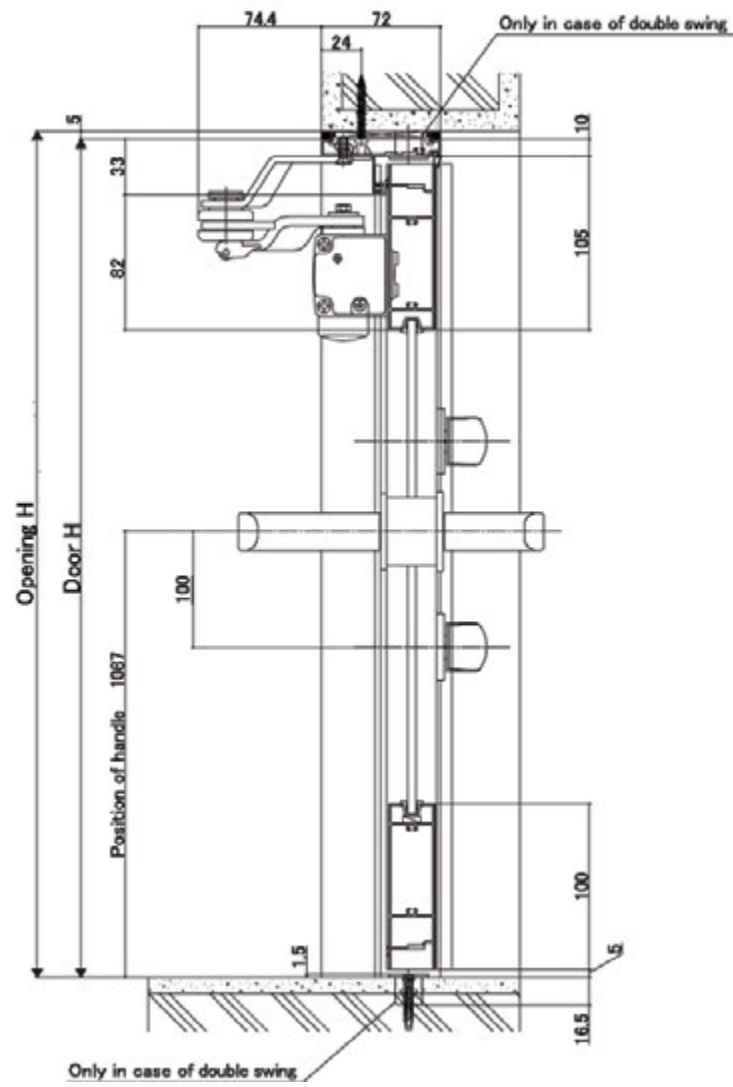

< Vertical section: Single & double in-swing door >

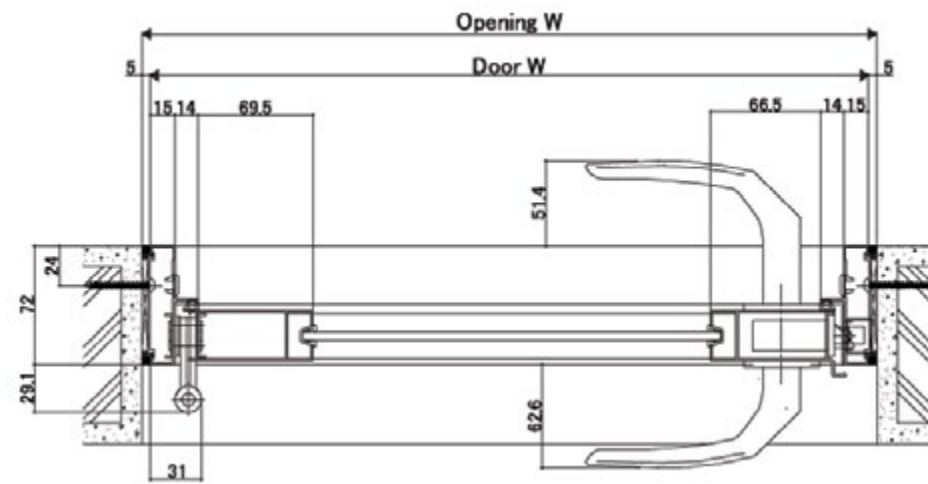
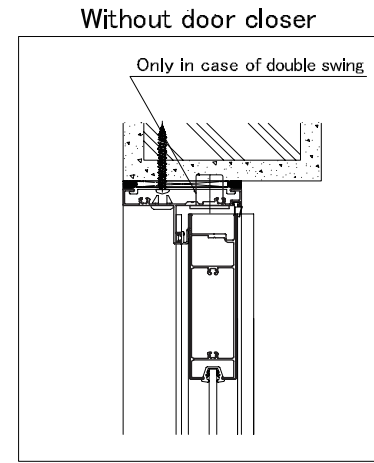

< Horizontal section: Single in-swing door >

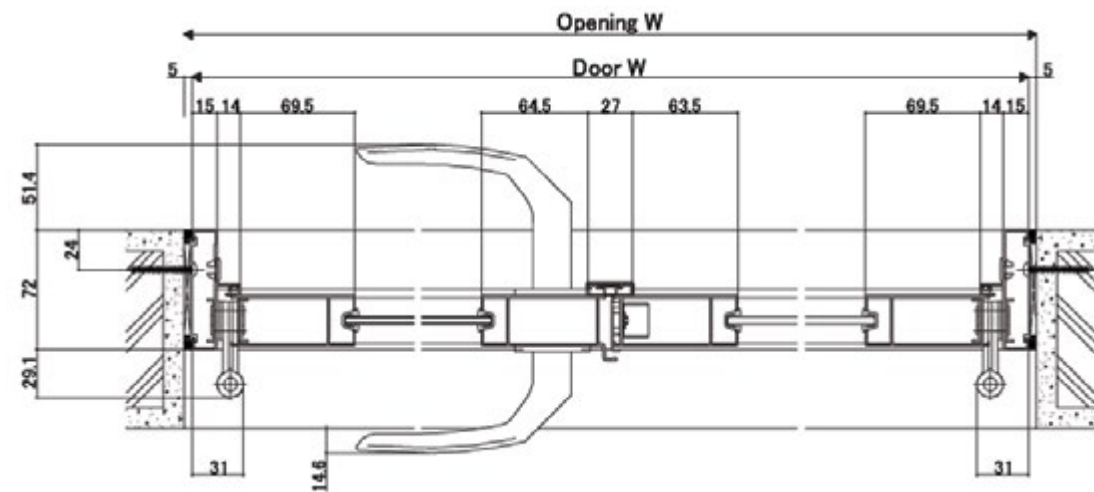

< Horizontal section: Double in-swing door >

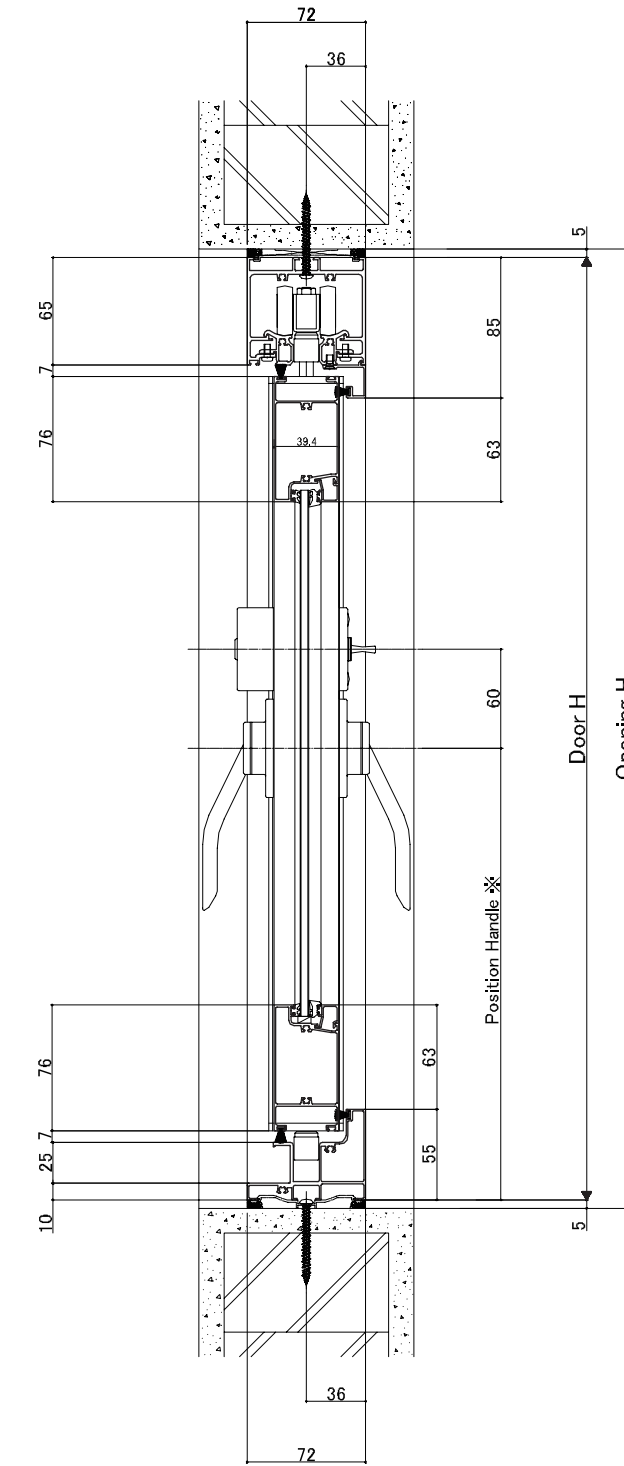

< Vertical section: Folding Door >

	※ Handle Position
H > 1600	1100
H ≤ 1600	H/2-15

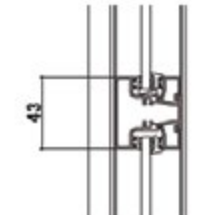

< Vertical section: With middle bar >

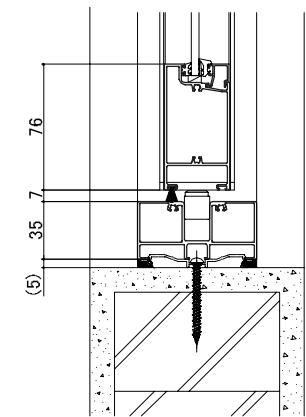

< Vertical section: Flat sill >

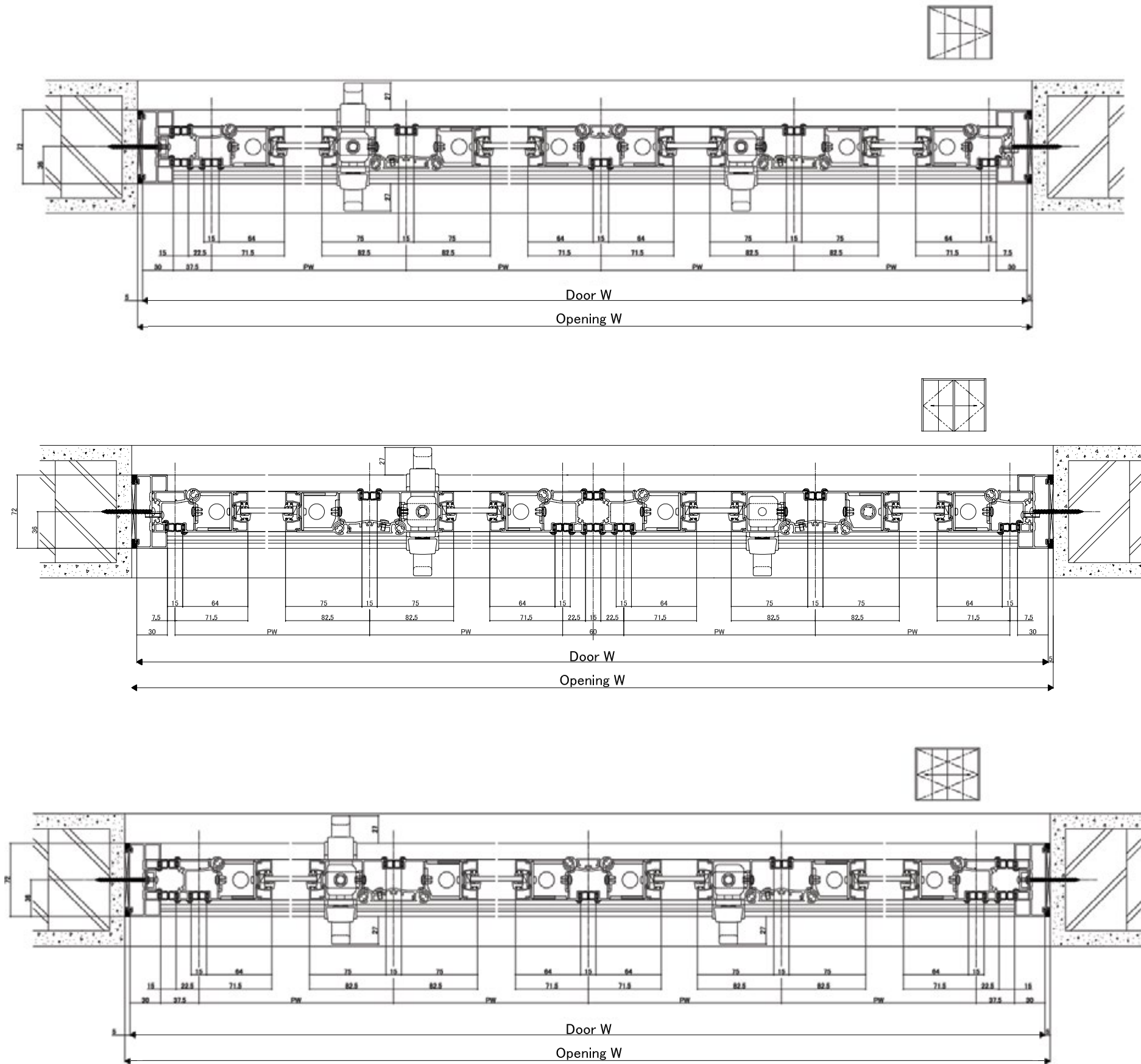

<Horizontal section : Folding Door>

**WE 70 COMBINATION**

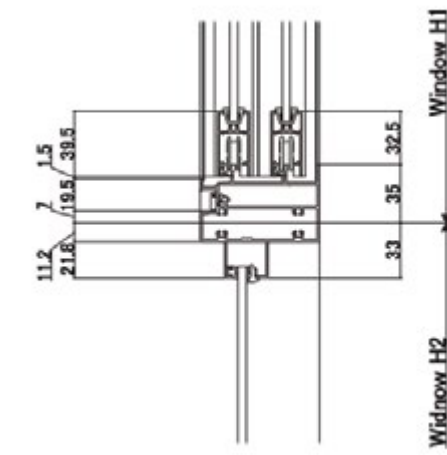

< Vertical section: Sliding/Fixed transom >

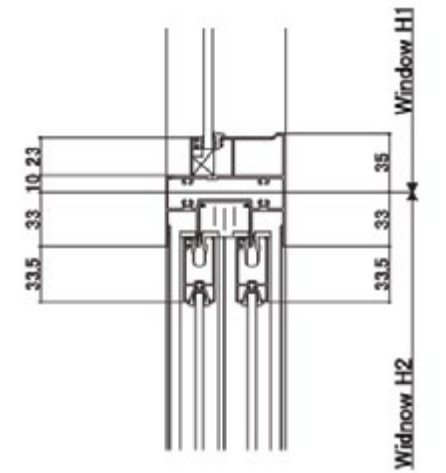

< Vertical section: Fixed/Sliding transom >

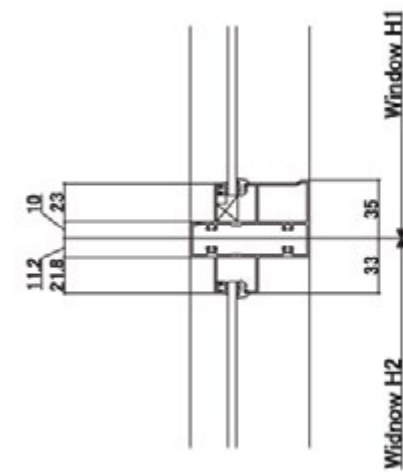

< Vertical: Fixed/Fixed transom >

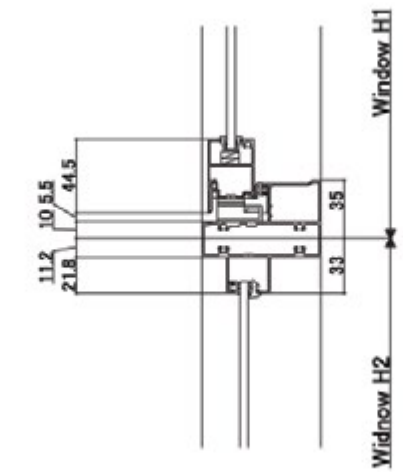

< Vertical: Projection/Fixed transom >

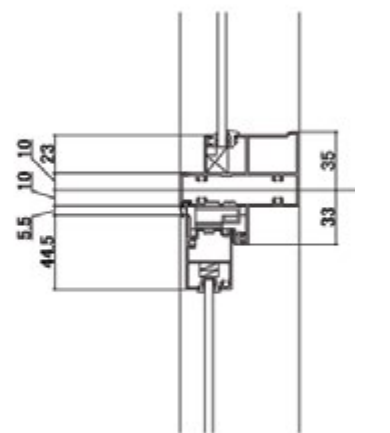

< Vertical: Fixed/Projection transom >



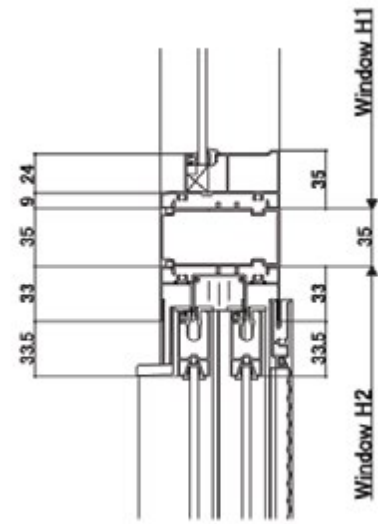

< Transom >

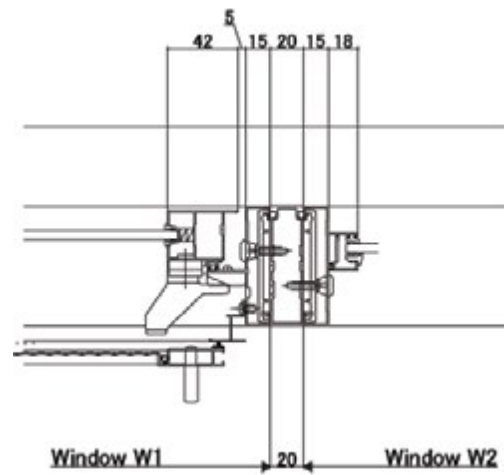

< Mullion >

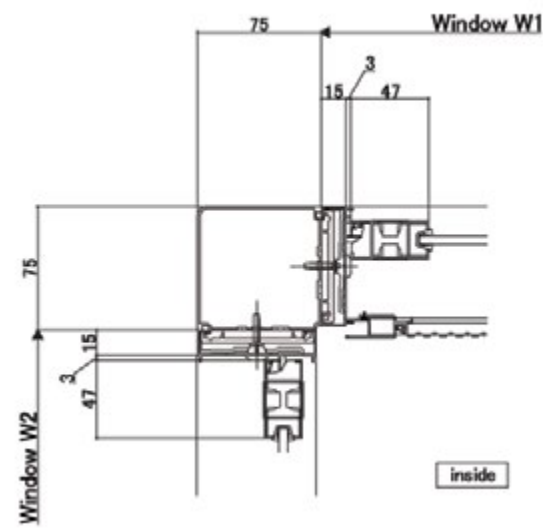

< Corner mullion >

**WE 40 SERIES**

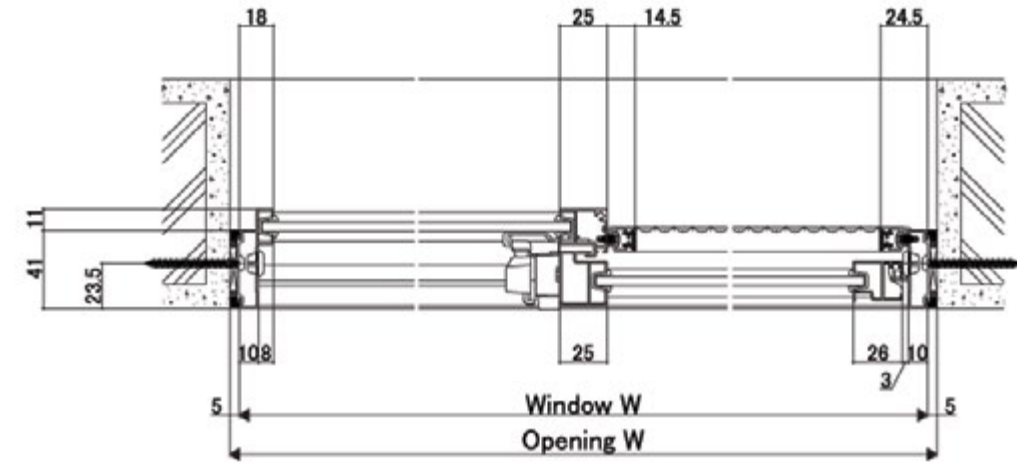

< Horizontal section: Single sliding window >

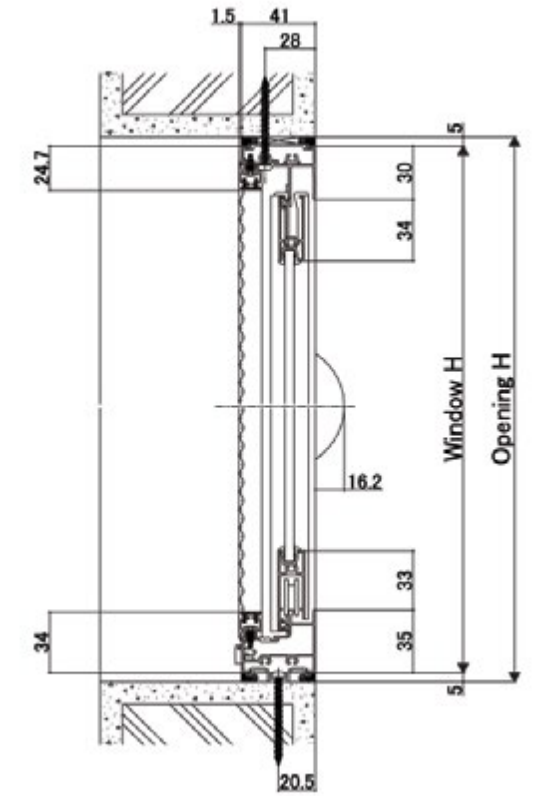

< Vertical section: Single sliding (screen side) >

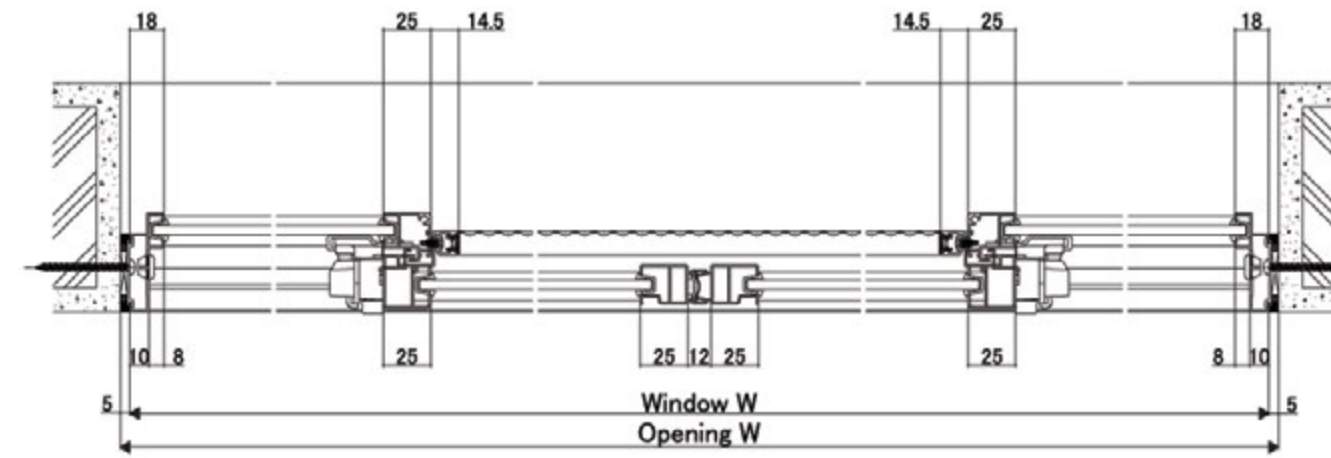

< Horizontal section: Center sliding window >

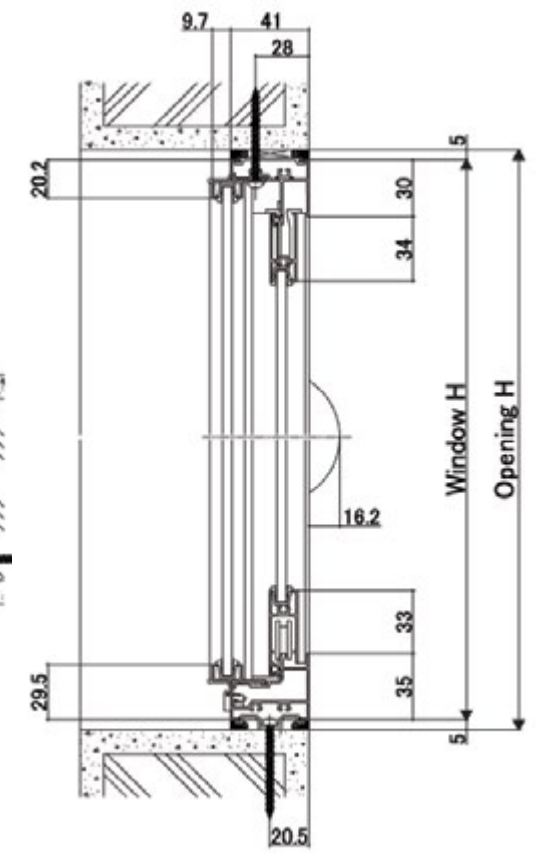

< Vertical section: Single sliding window (panel side) >

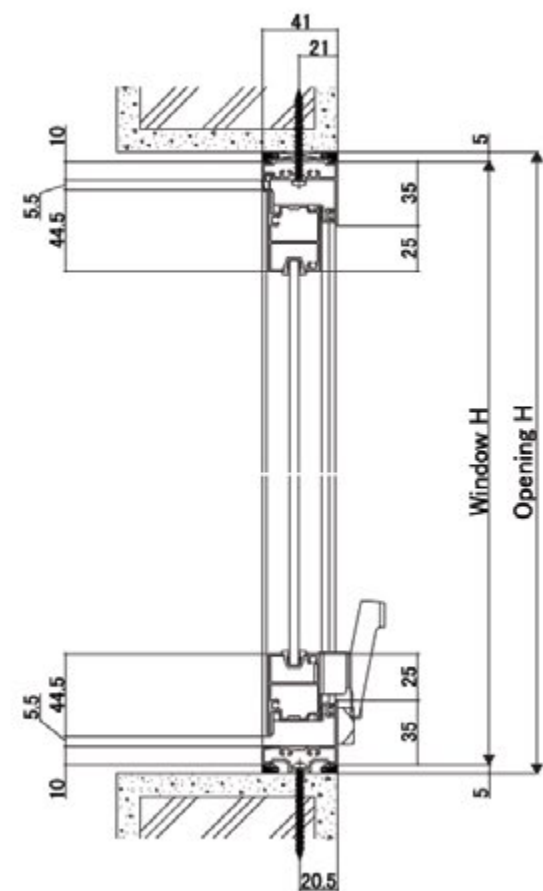

< Vertical section: Awning window >

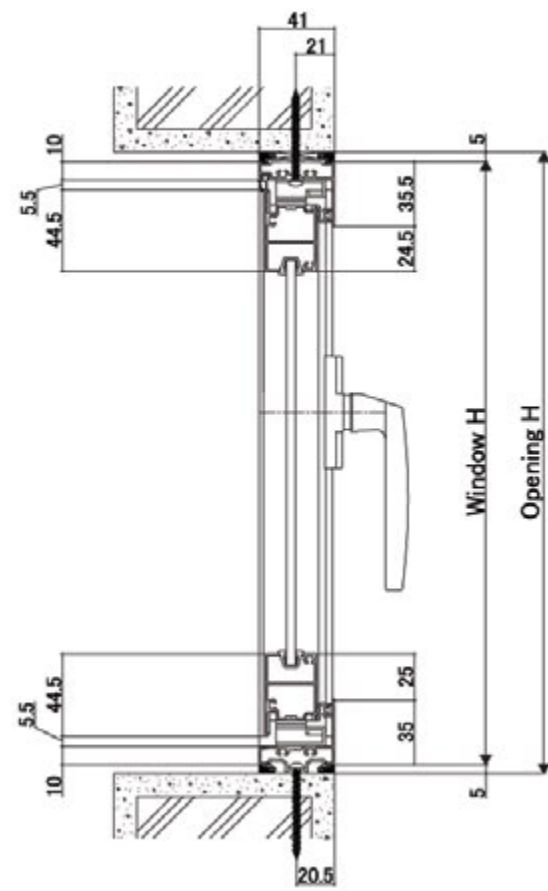

< Vertical section: Casement window >

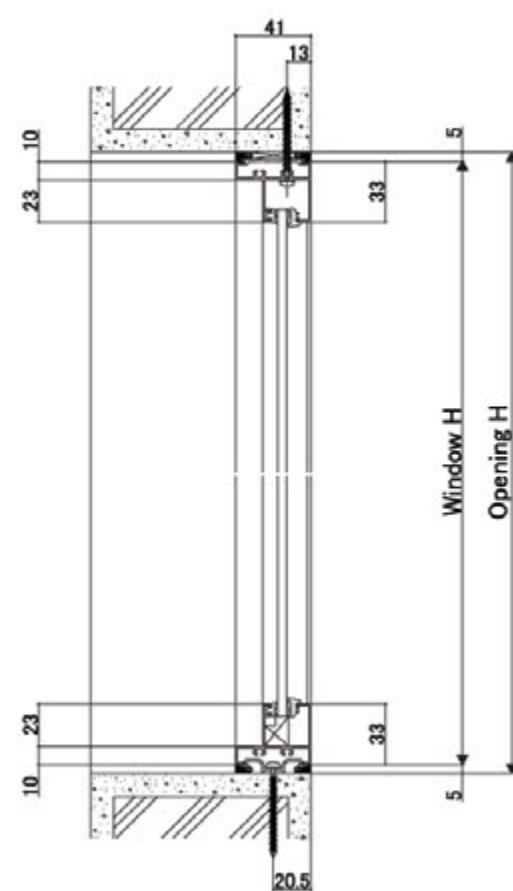

< Vertical section: Fixed window >

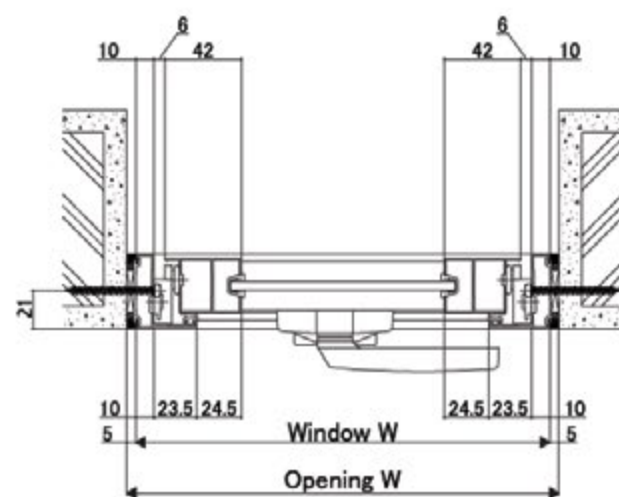

< Horizontal section: Awning window >

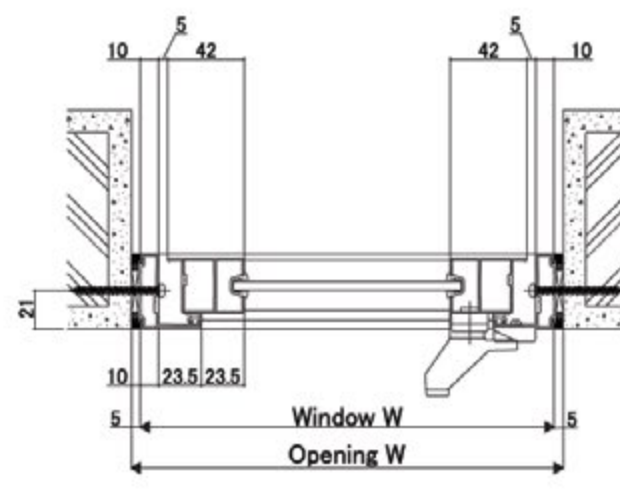

< Horizontal section: Casement window >

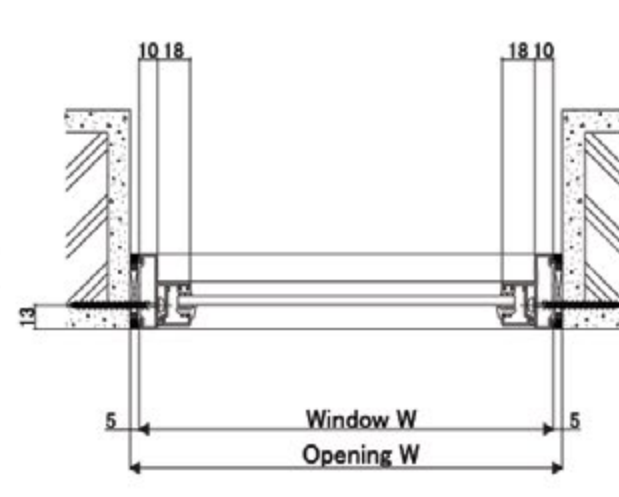

< Horizontal section: Fixed window >

## INTERIOR SERIES

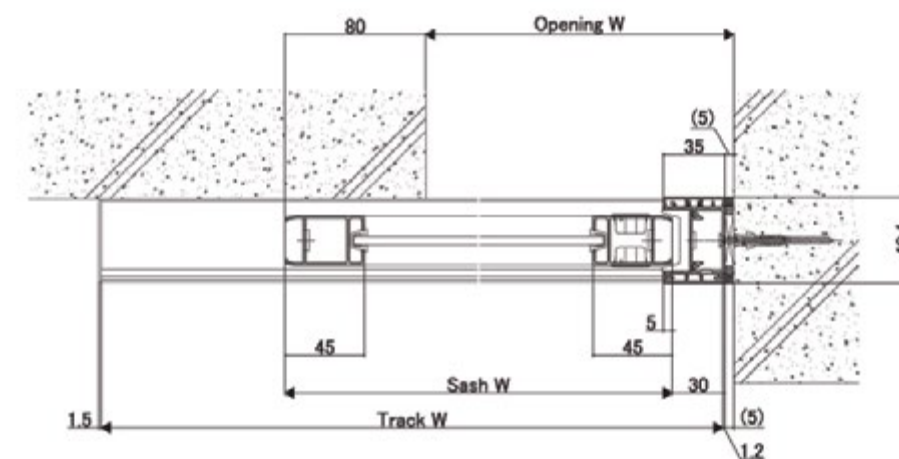

< Horizontal section: 1 panel on 1 track on-wall hanging door with jamb ( R ) >

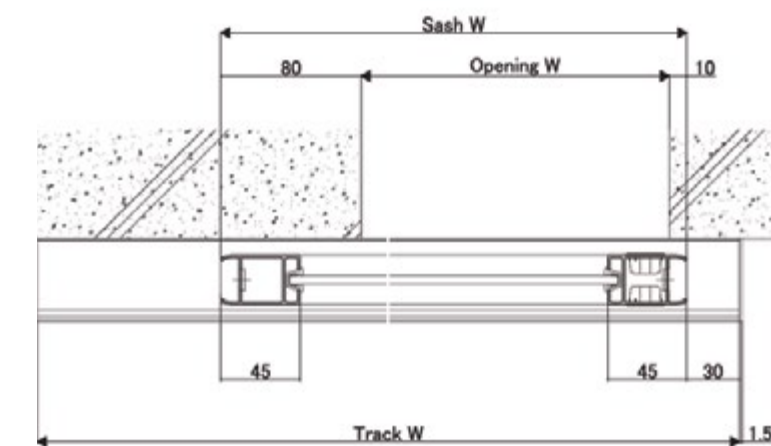

< Horizontal section: 1 panel on 1 track on-wall hanging door without jamb ( R ) >

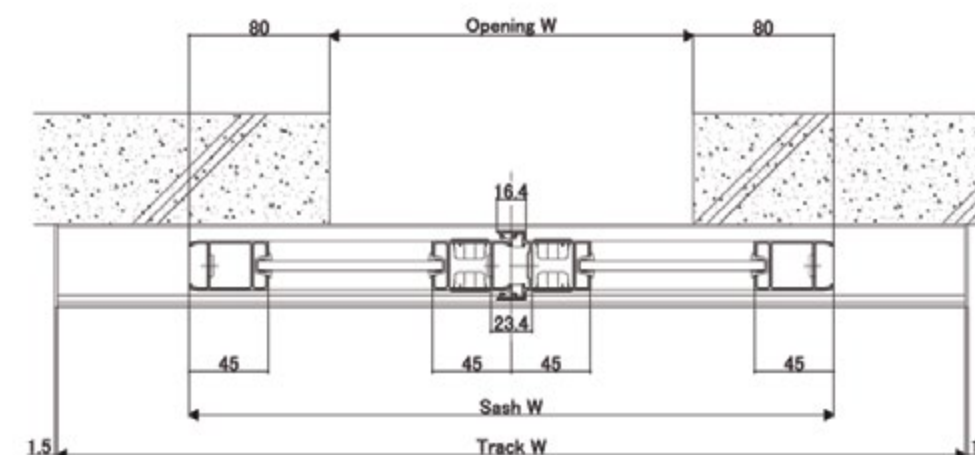

< Horizontal section: 2 panels on 1 track on-wall hanging door >

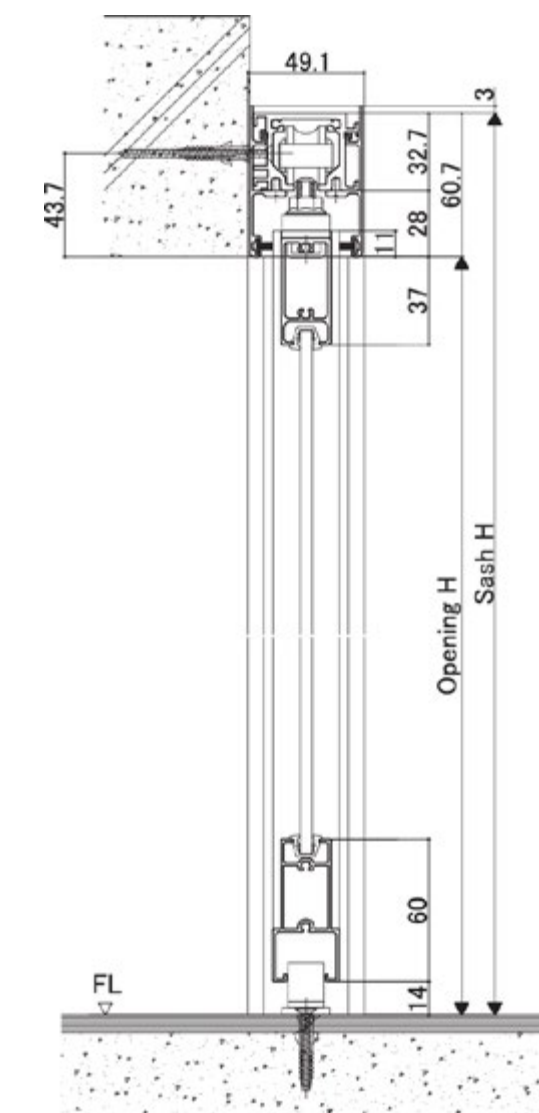

< Vertical section: 1 track on-wall hanging door >

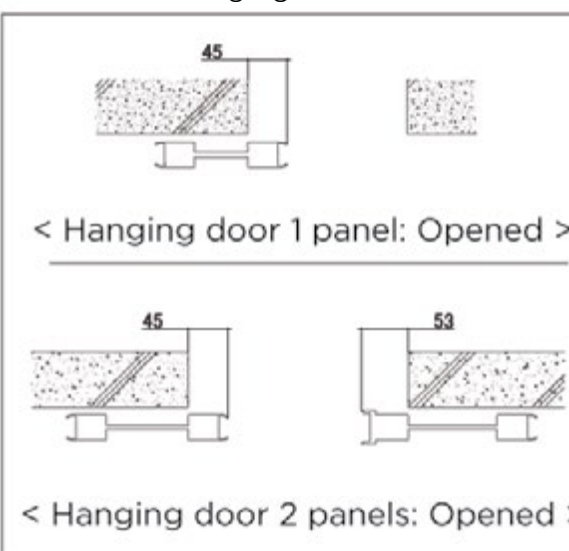

< Hanging door 2 panels: Opened >



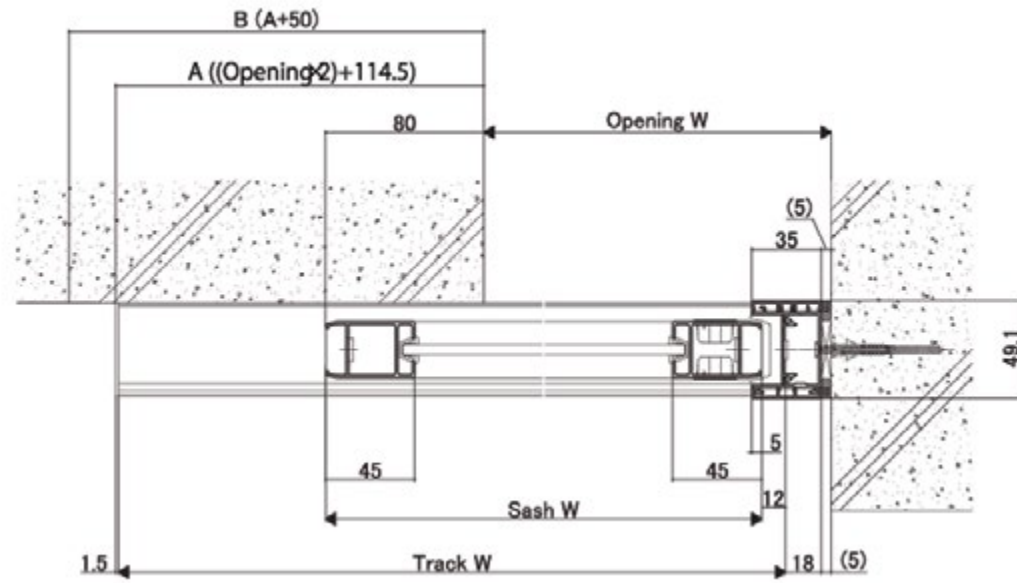

< Horizontal section: 1 panel on 1 track in-wall hanging door with jamb ( R ) >

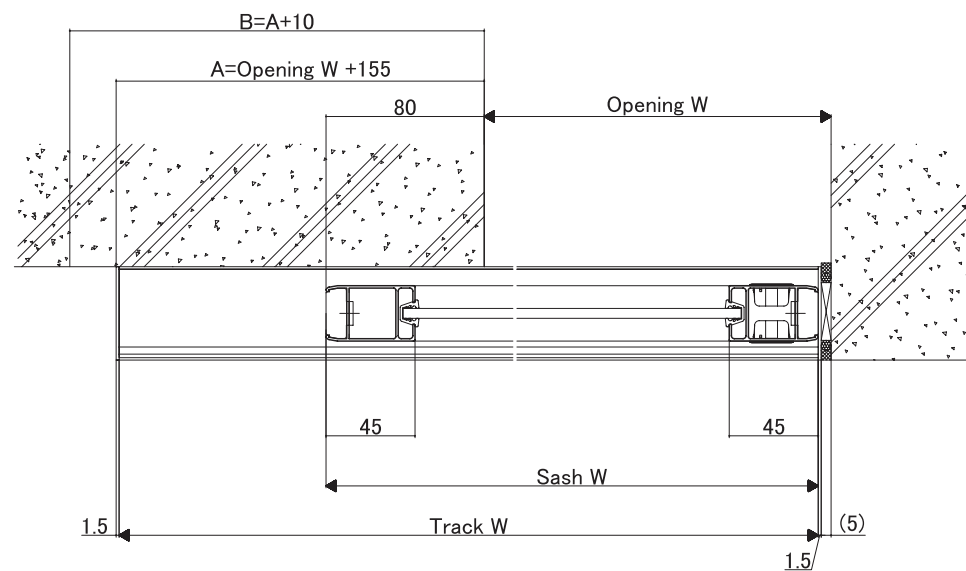

< Horizontal section: 1 panel on 1 track in-wall hanging door > \*opened

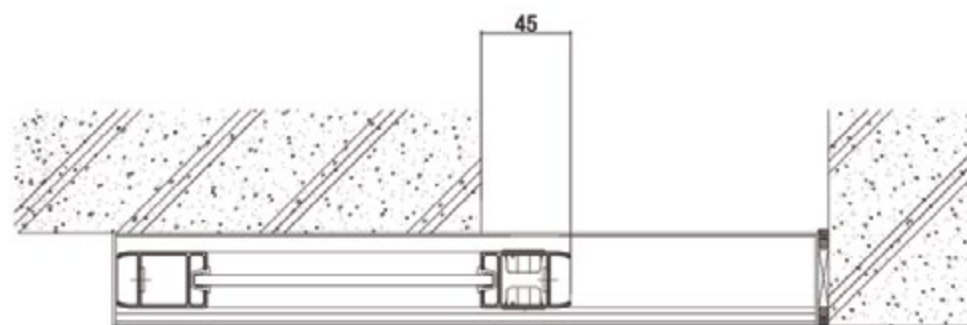

< Horizontal section: 2 panels on 1 track on-wall hanging door >

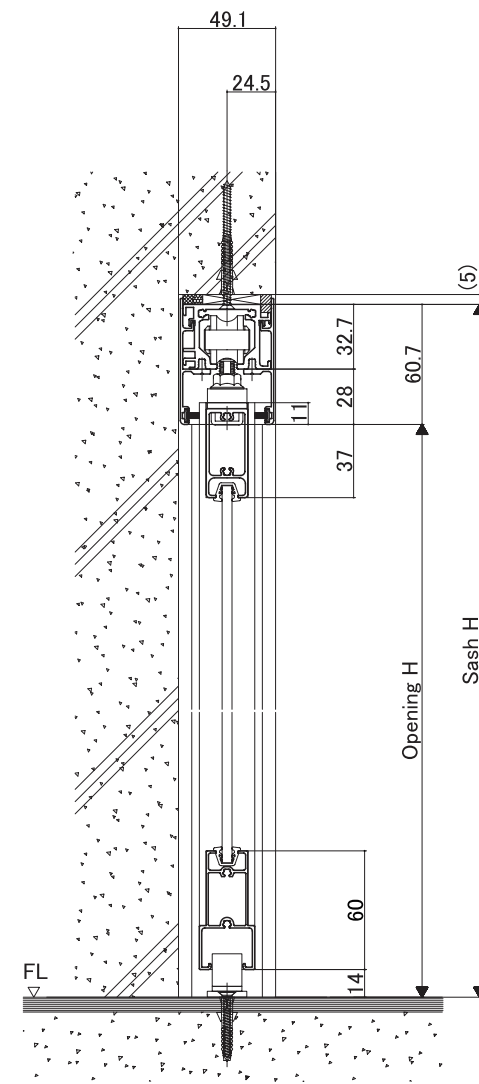

< Vertical section: 1 track in-wall hanging door >

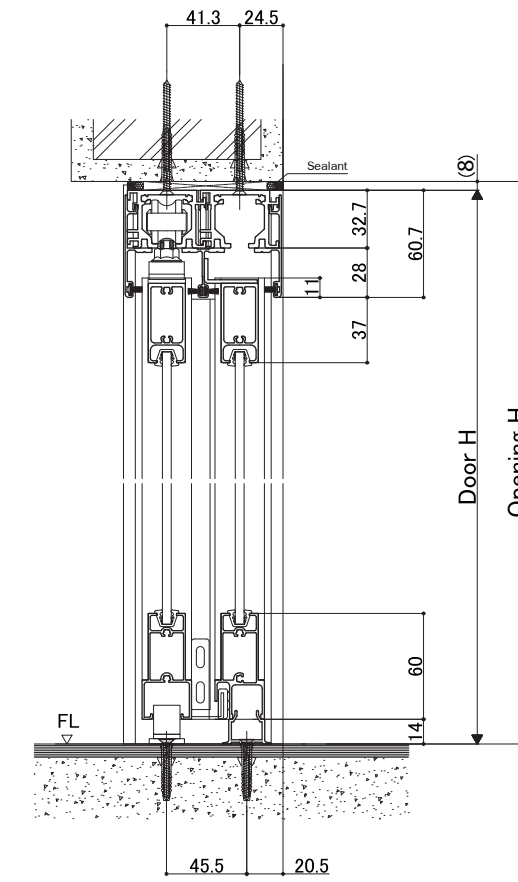

< Vertical section: 2 panels on 2 tracks in-wall hanging door >

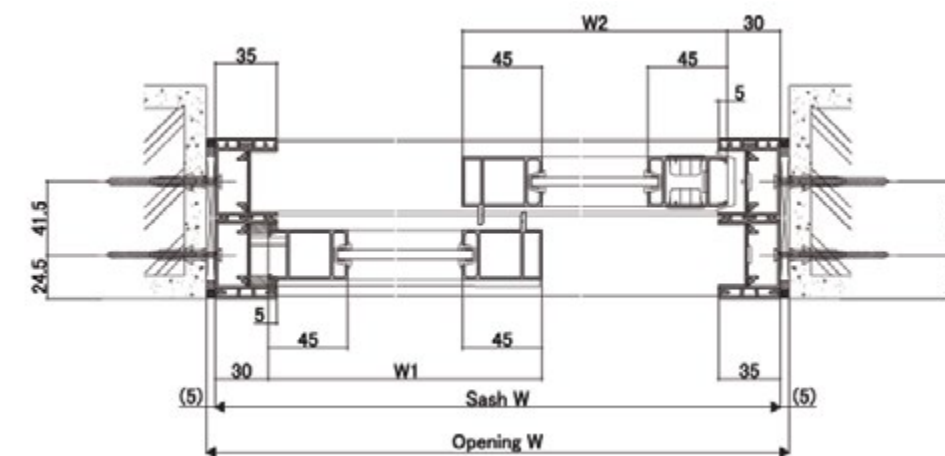

< Horizontal section: 2 panels on 2 tracks in-wall hanging door >

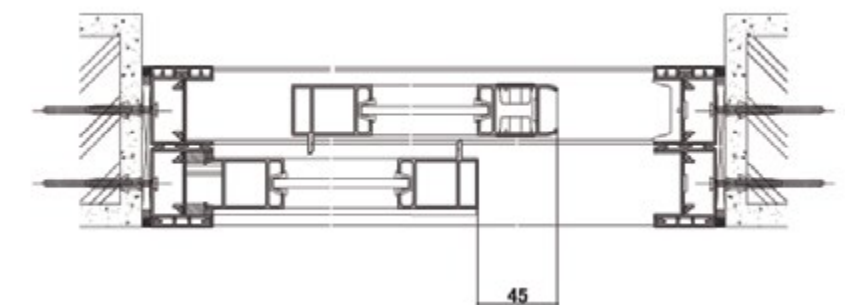
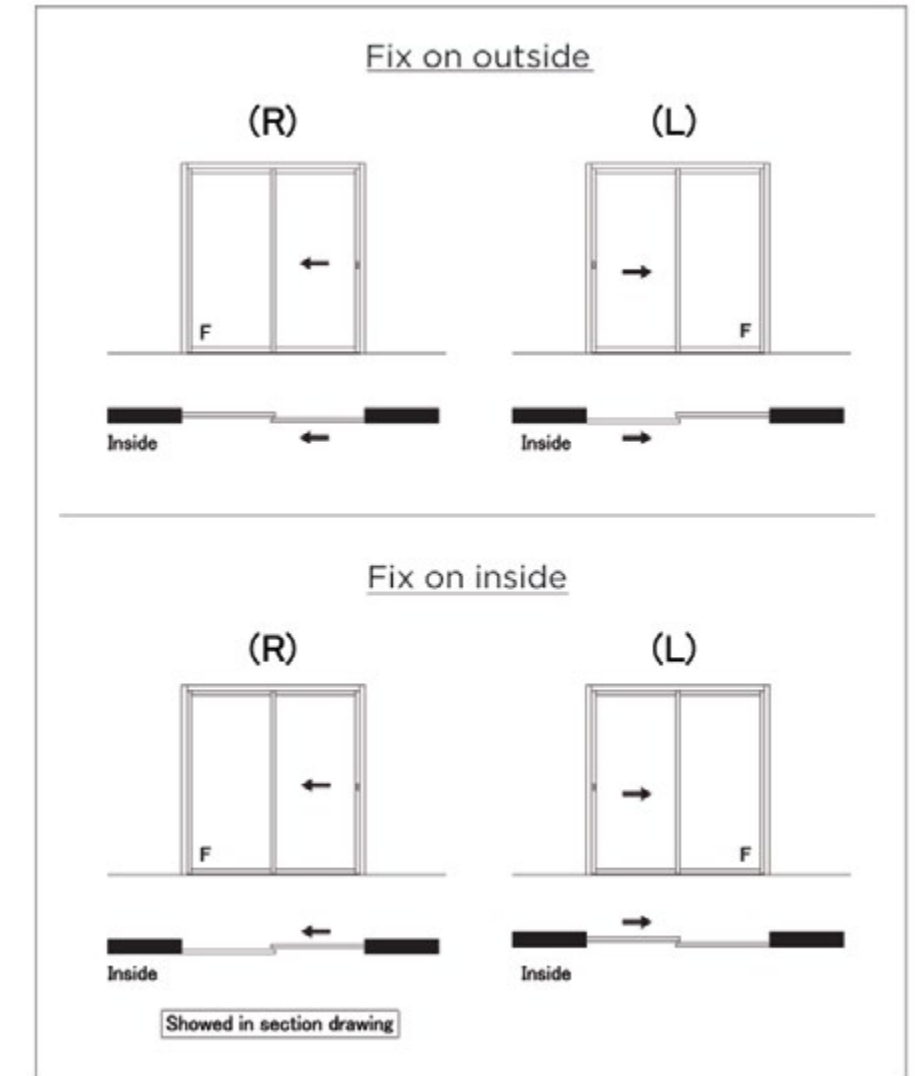

< Horizontal section: 2 panels on 2 tracks hanging door > \*opened

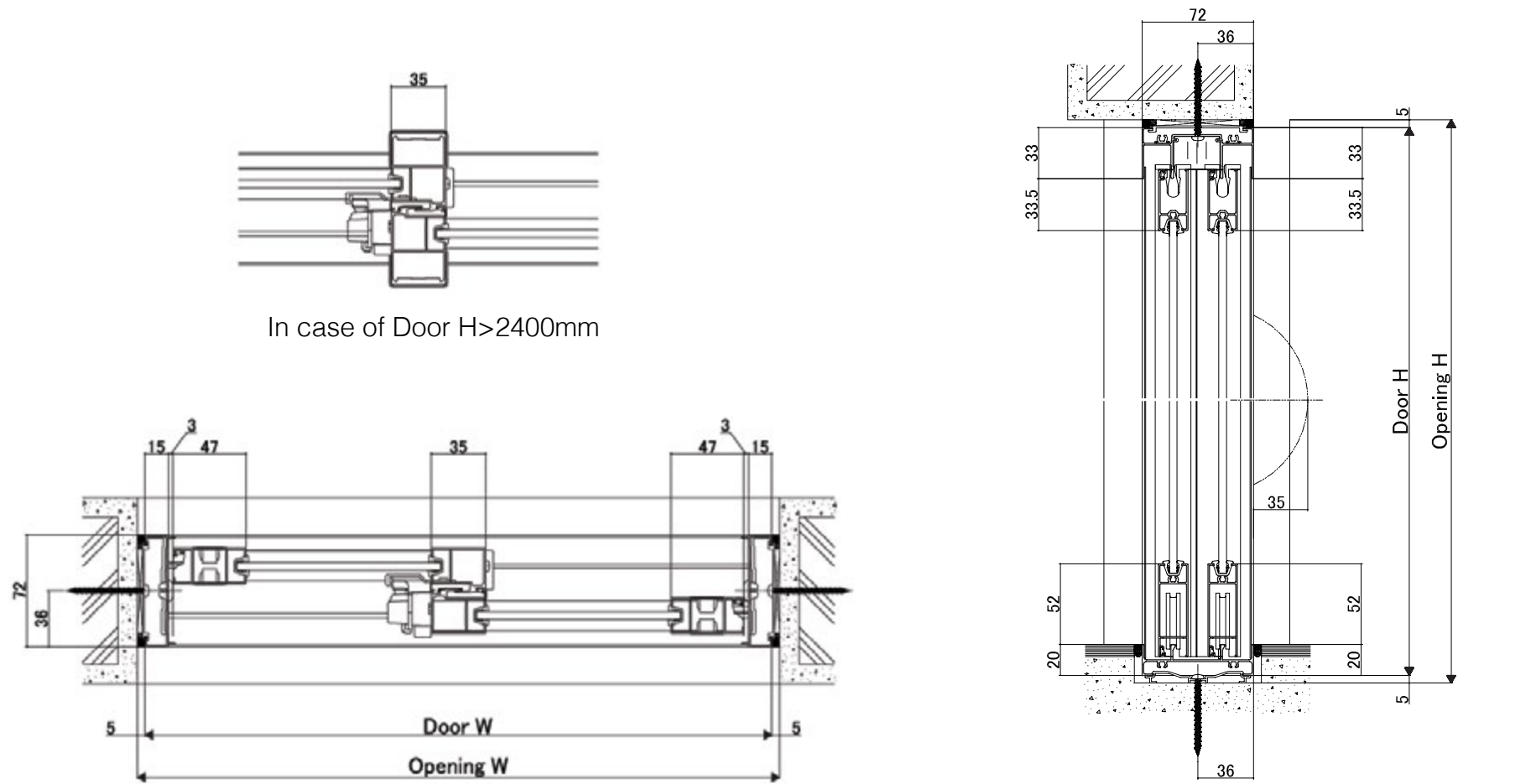

< Horizontal section: 2 panels partition door >

< Vertical section: 2 and 4 panels partition door >

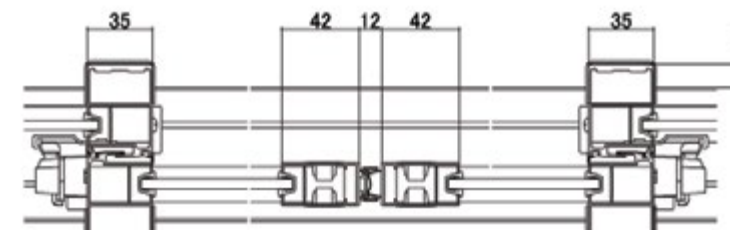

In case of Door H>2400mm

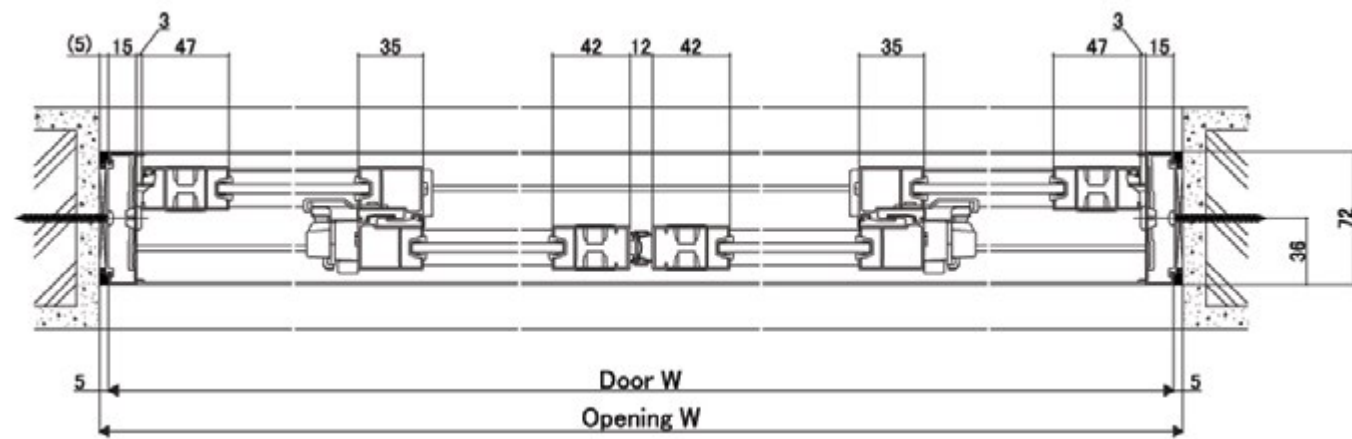

< Horizontal section: 4 panels partition door >

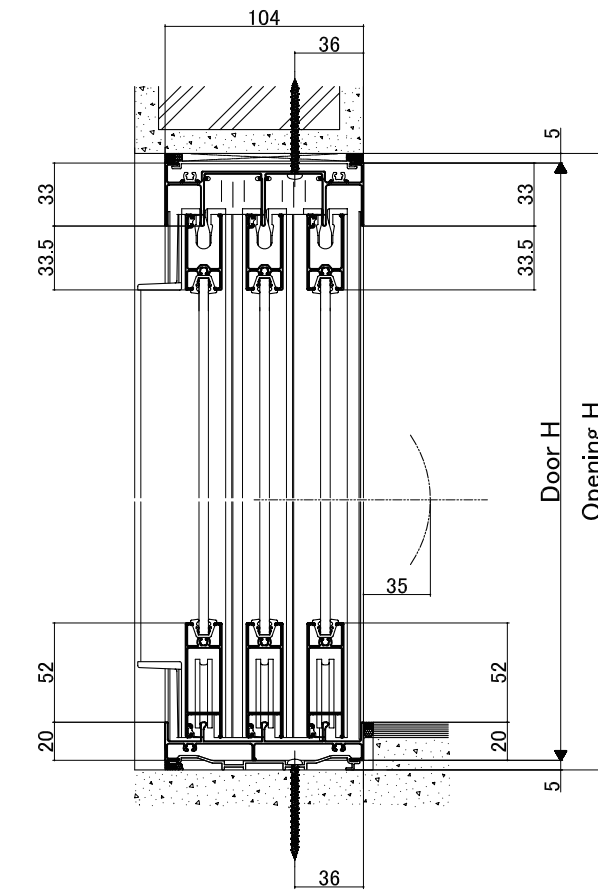

< Vertical section: 3 and 6 panels partition door >

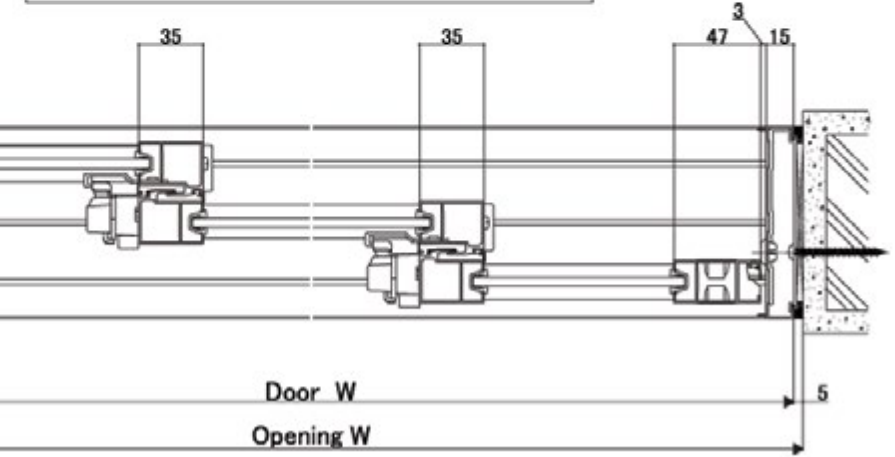
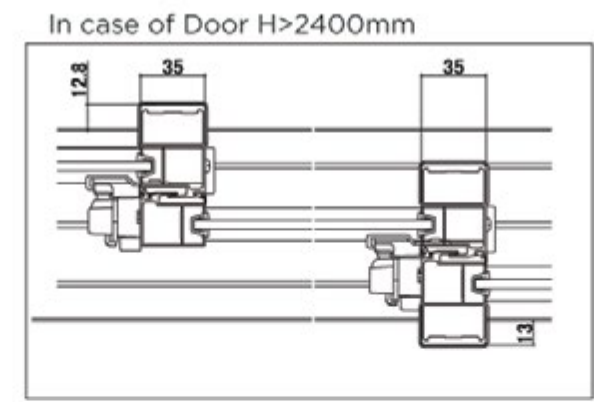

< Horizontal section: 3 panels partition door >

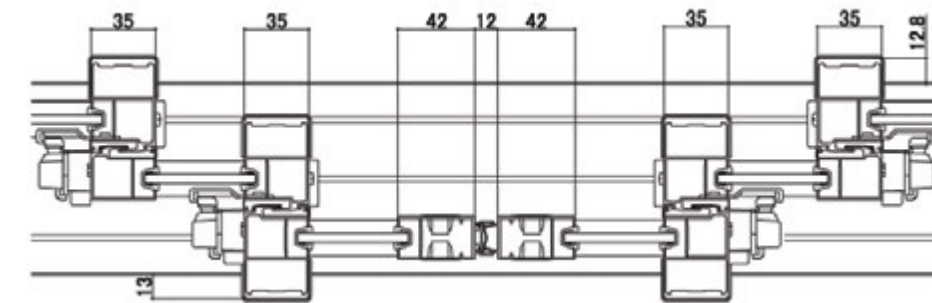

In case of Door H>2400mm

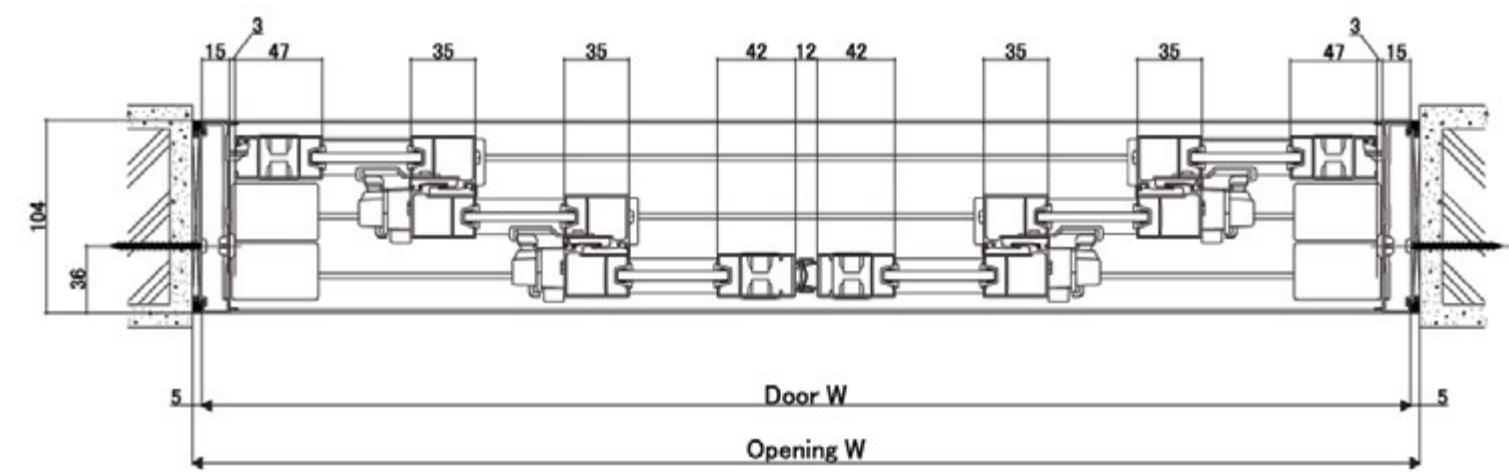

< Horizontal section: 6 panels partition door >



**GIESTA OUT-SWING SERIES**

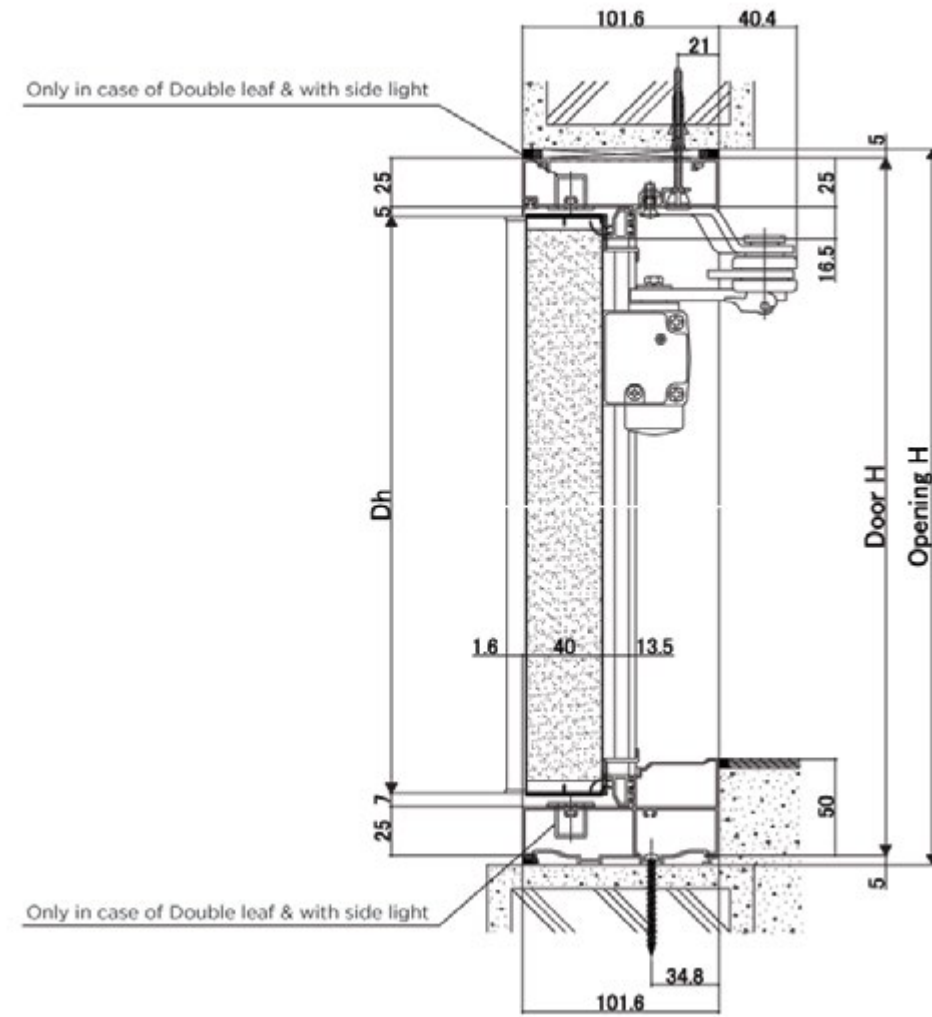

< Vertical section: Single & Double leaf with sill >

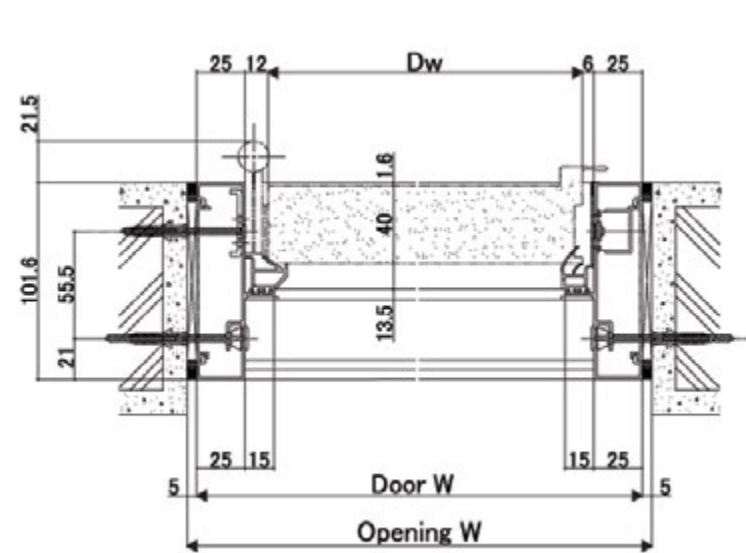

< Horizontal section: Single leaf >

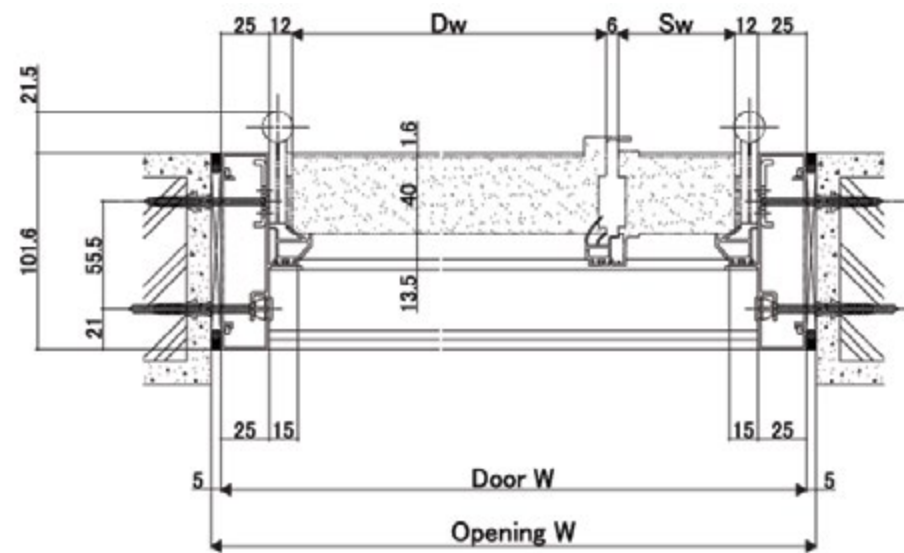

< Horizontal section: Double leaf or with side light >

**GIESTA IN-SWING SERIES**

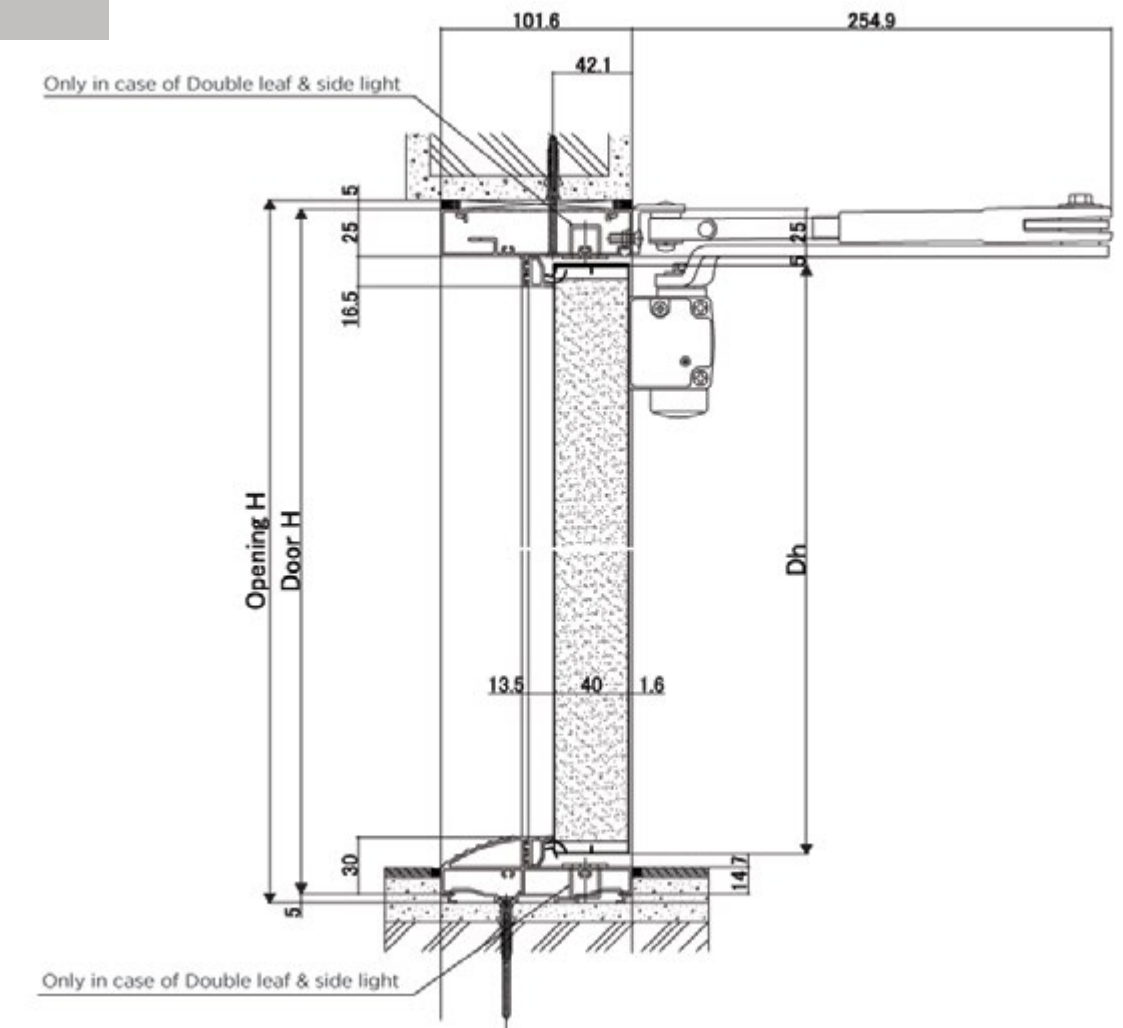
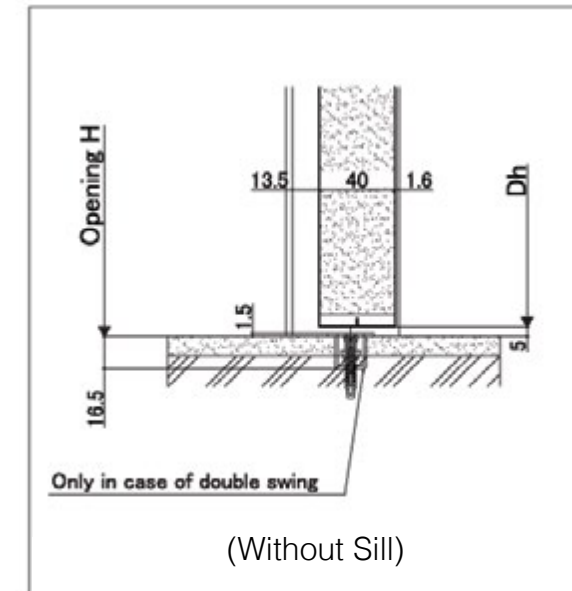

< Vertical section: Single & Double leaf >

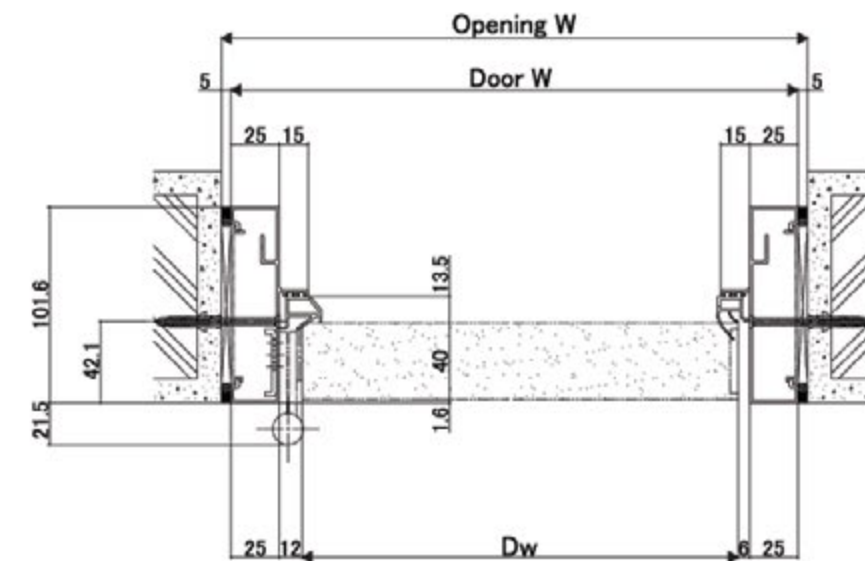

< Horizontal section: Single leaf >

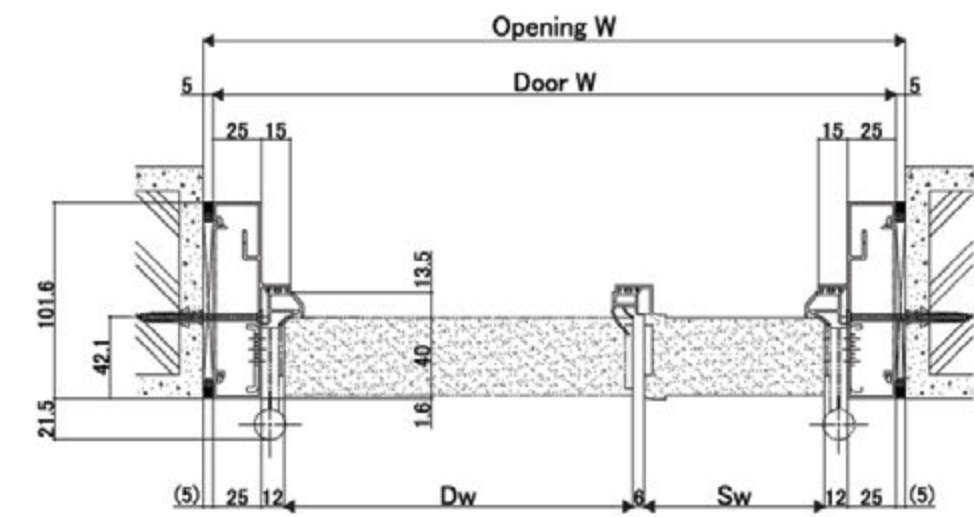

< Horizontal section: Double leaf or with side light >

# ALUMINUM EXTERIOR SERIES

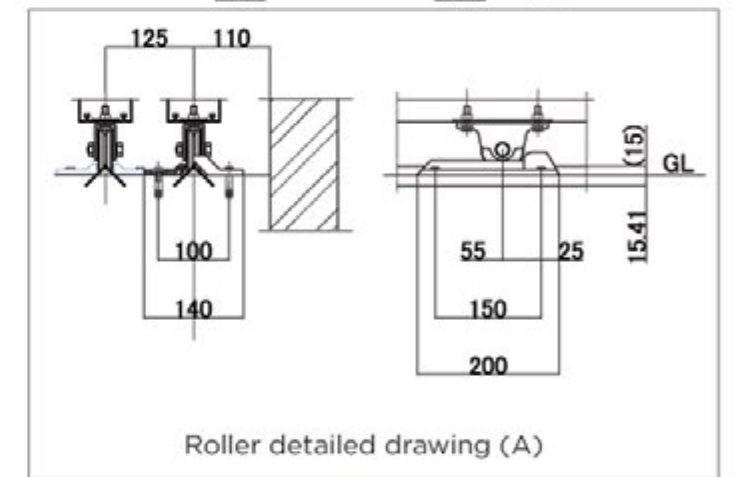
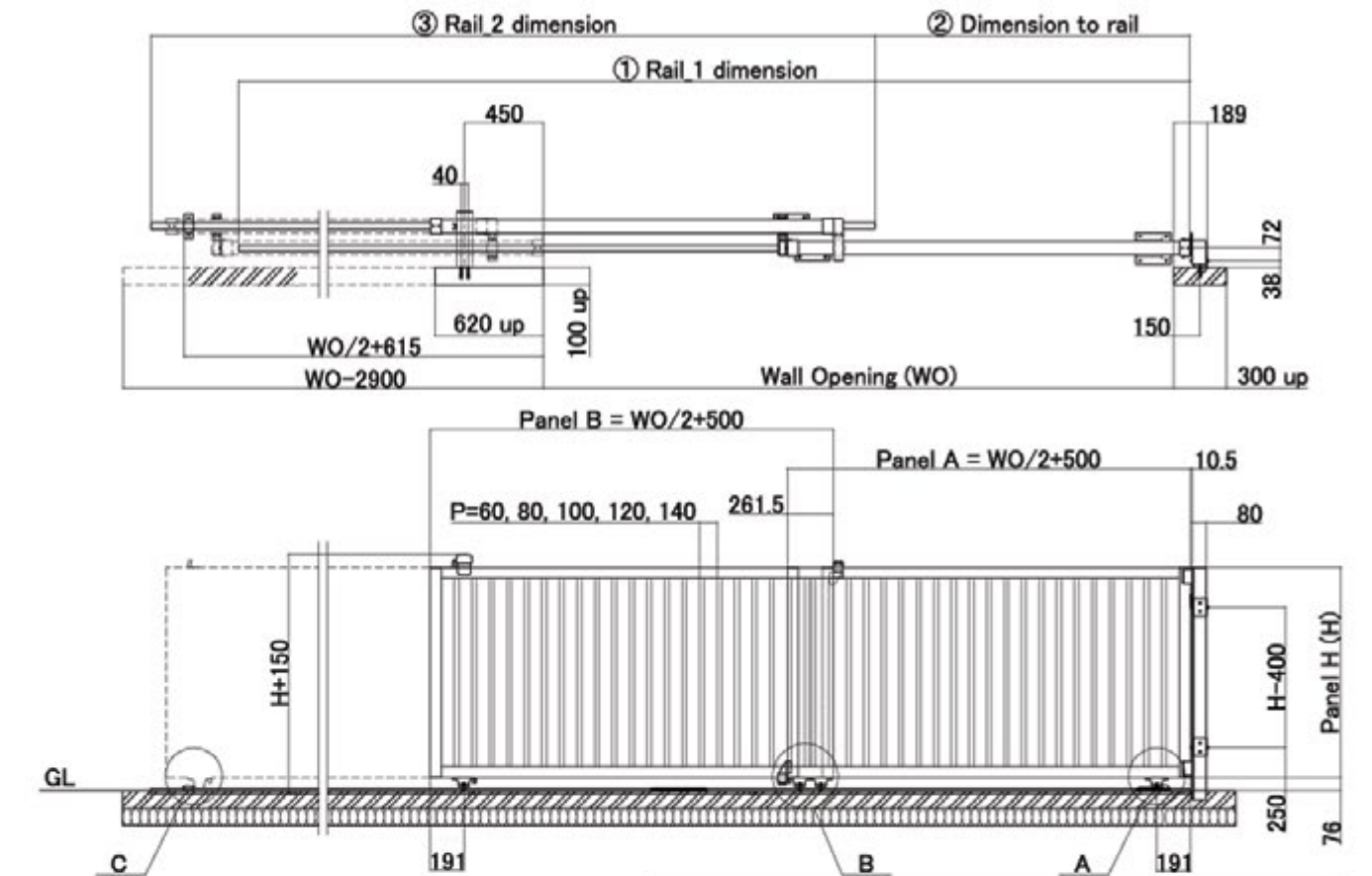
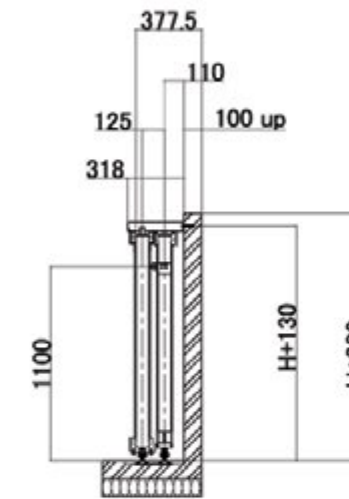
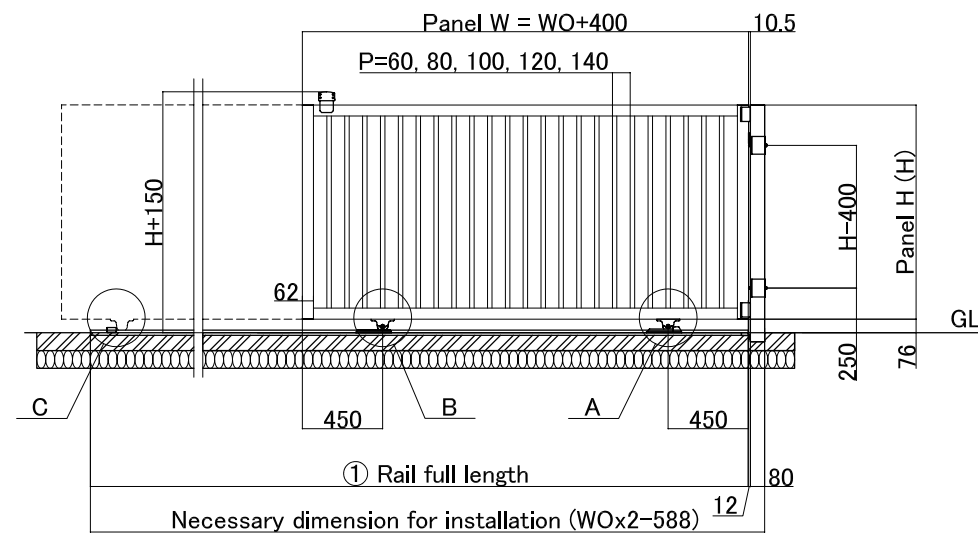
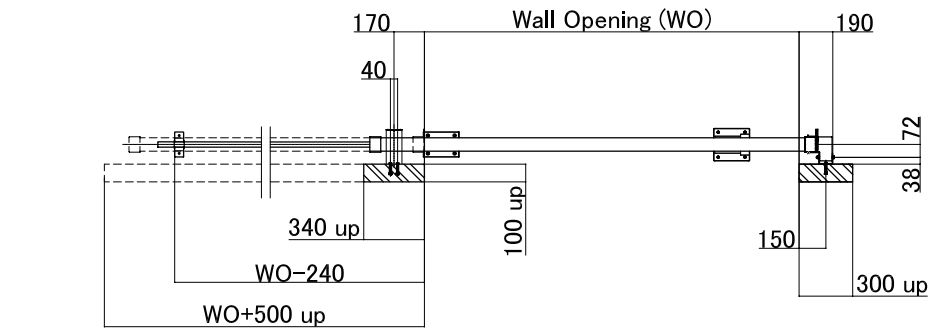
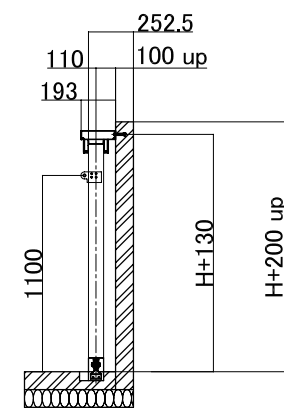
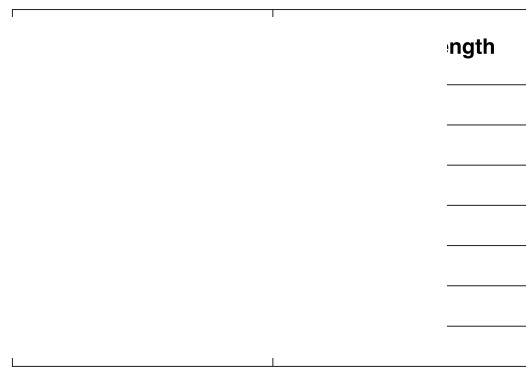
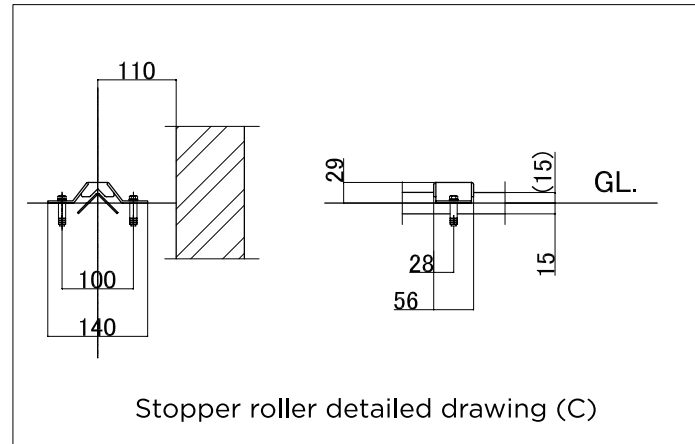

Wall Opening (WO)	① Rail Dimension (1)	② Dimension to rail	③ Rail Dimension (2)
5000+5500	9000	3000	3000
5501+6000	9500	3000	3000
6001+6500	10500	3500	3500
6501+7000	11000	3500	3500
7001+7500	12000	4000	4000
7501+8000	12500	4000	4000

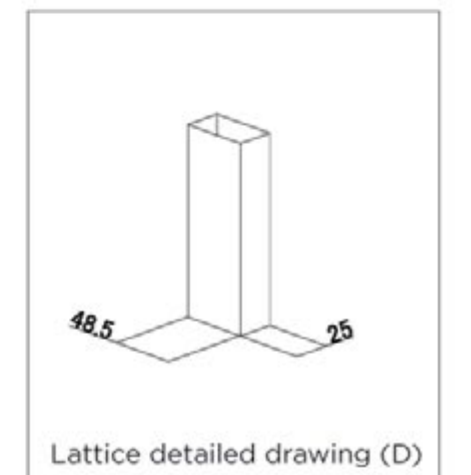
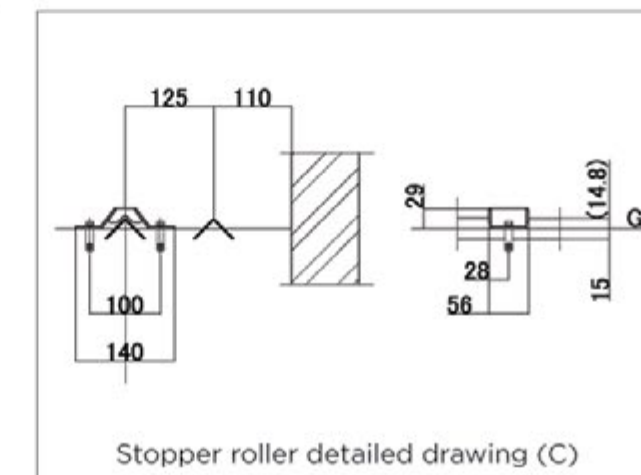
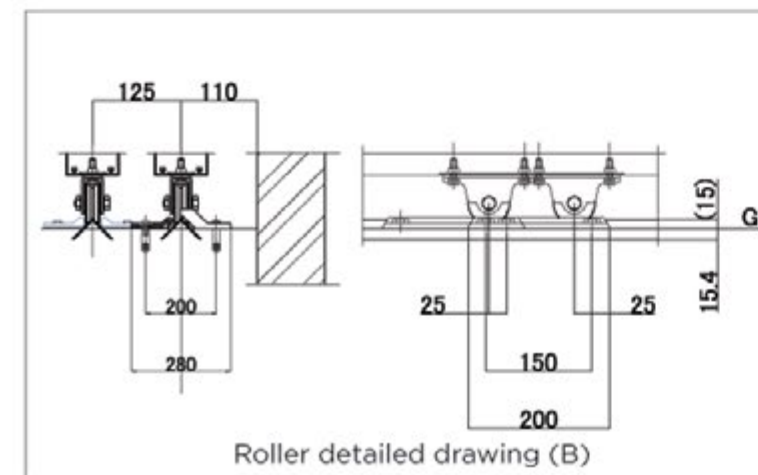
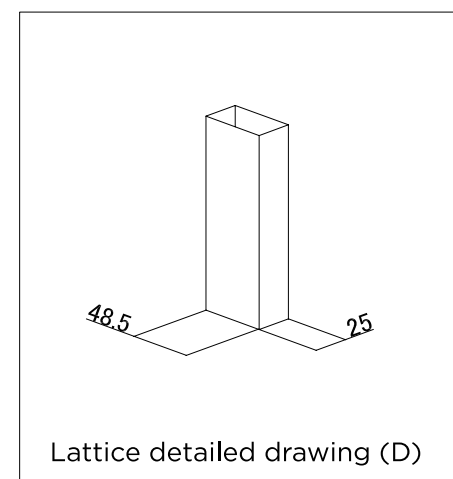
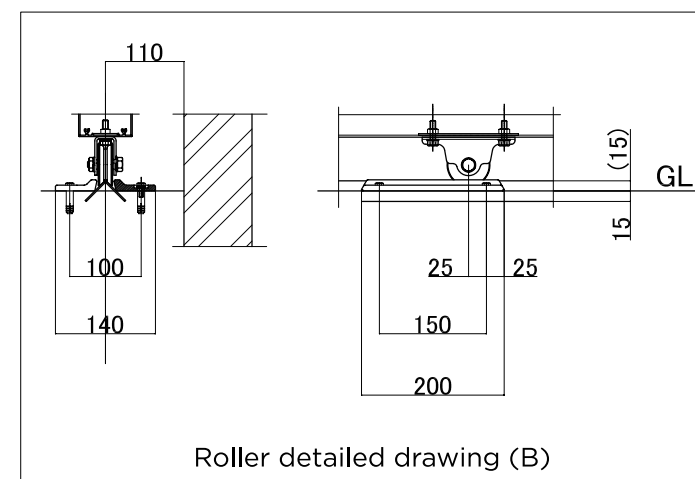
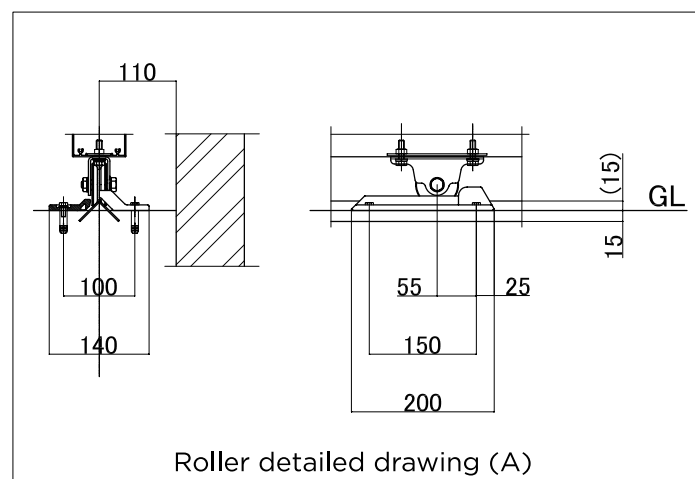



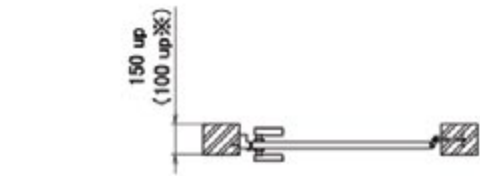

H	a
1200-1299	(H+90)-315
1300-1475	(H+90)-465
1476-1600	(H+90)-665

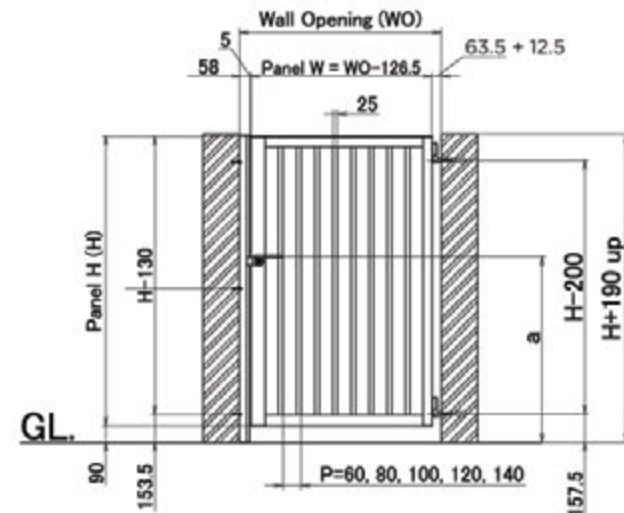

< Single swing >

Hinge detail

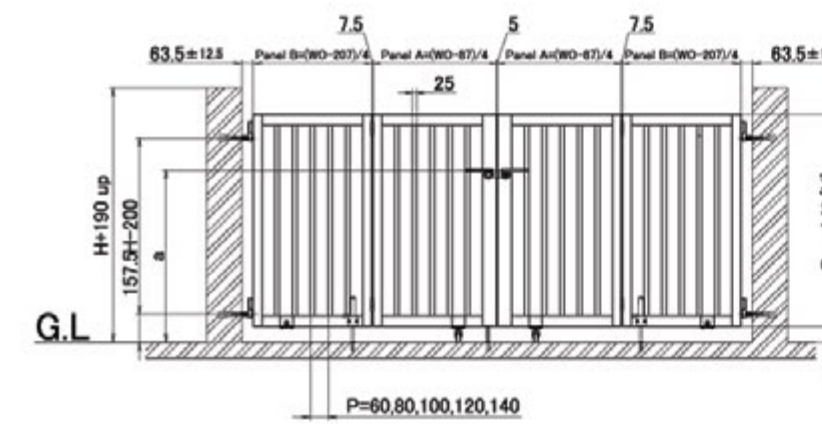
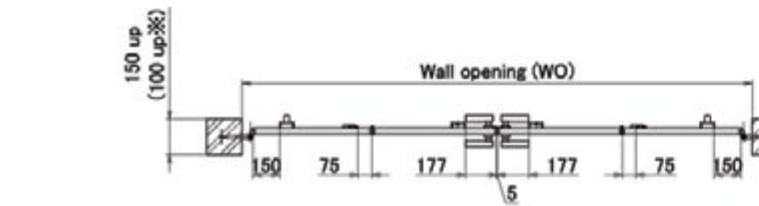
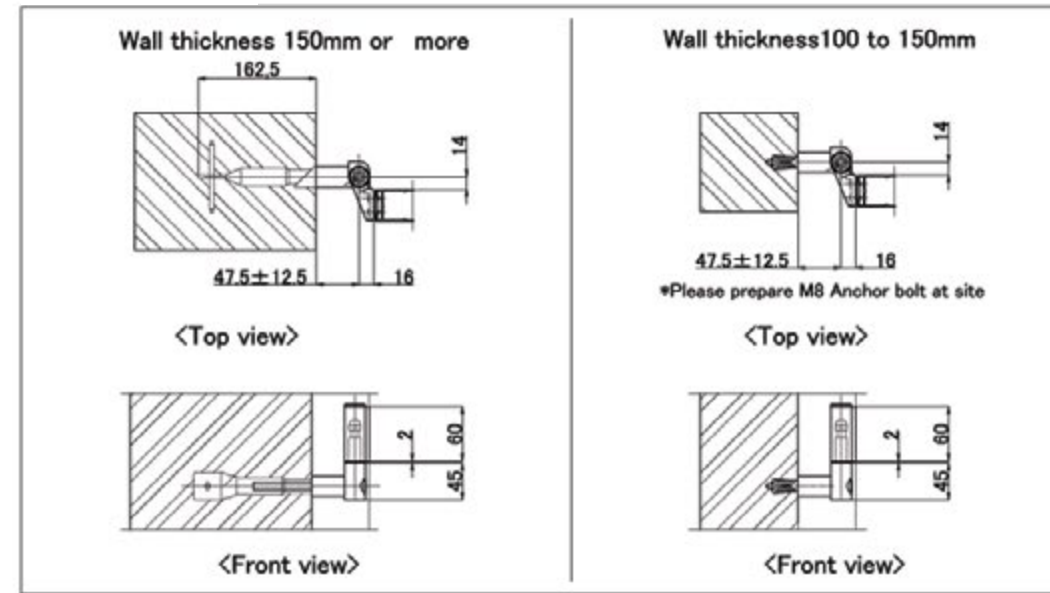

Folding gate (4 panels)

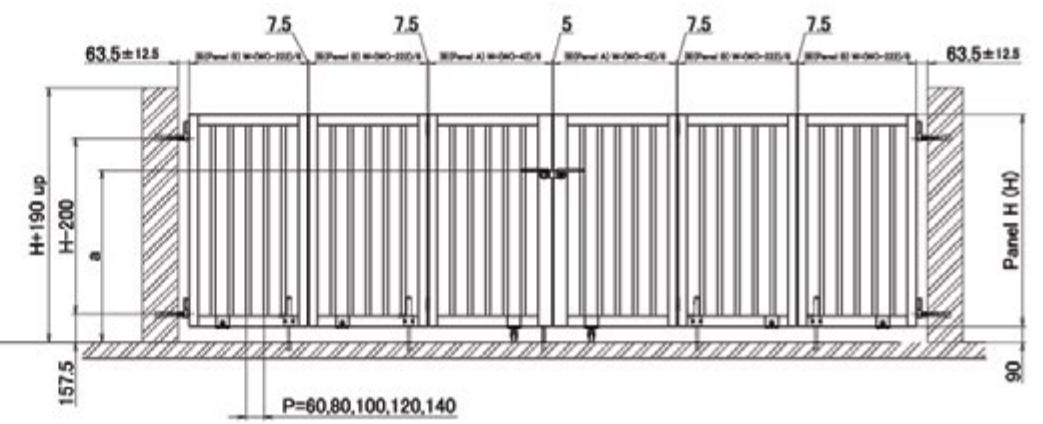
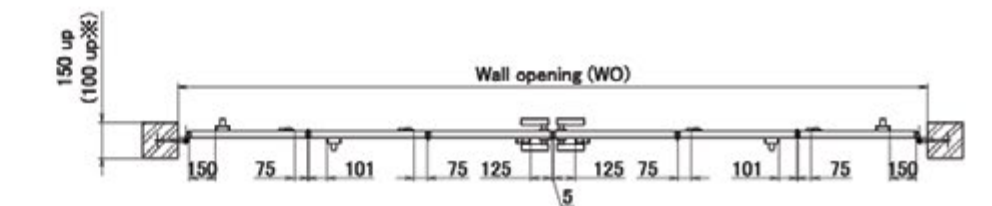

Folding gate (6 panels)

Stopper detail

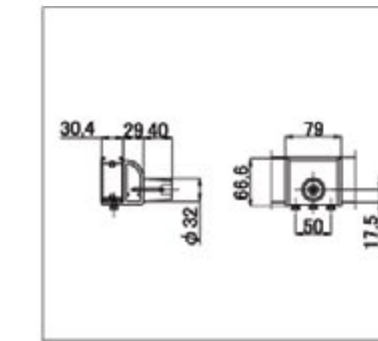

Drop bar detail

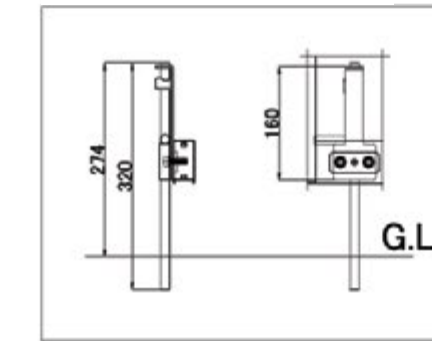

Roller detail

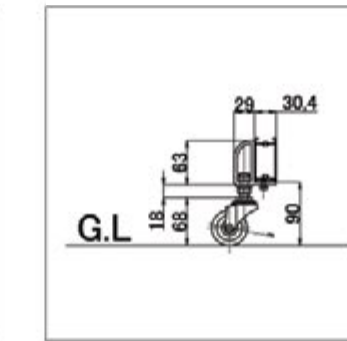

H	a
1200-1299	(H+90)-315
1300-1475	(H+90)-465
1476-1600	(H+90)-665



Dead bolt detail

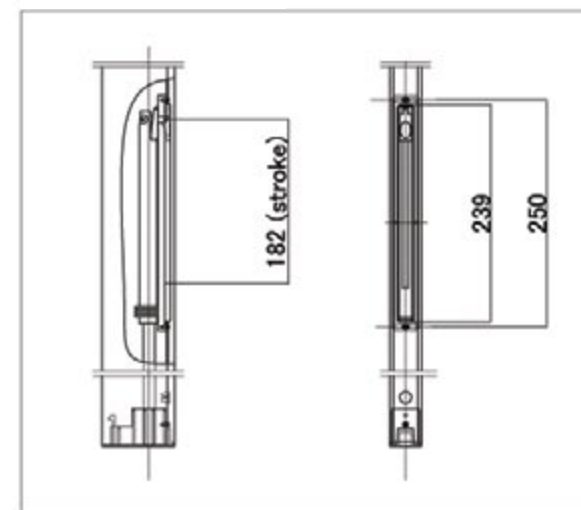

Dead bolt catch detail

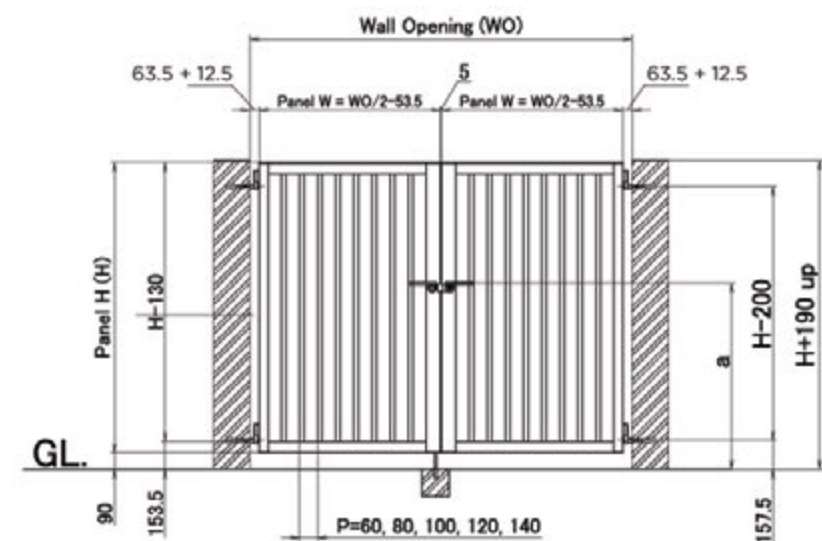
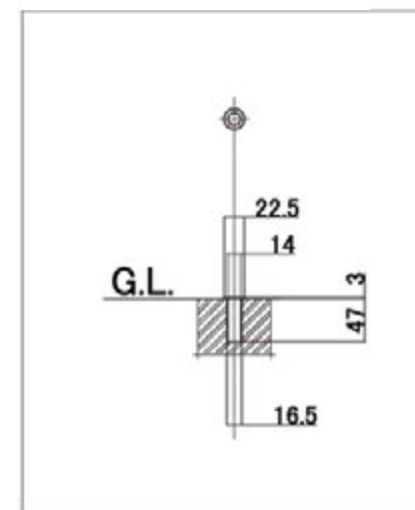

< Double swing >

Hinge detail

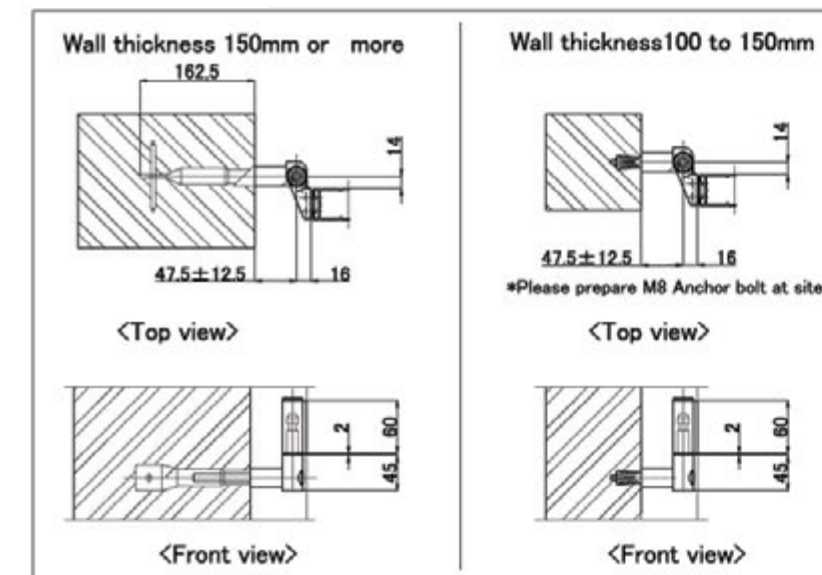

Dead bolt detail

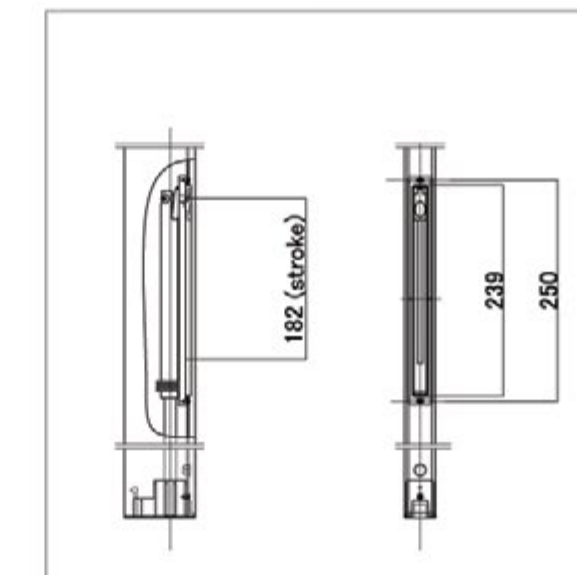

Dead bolt catch detail

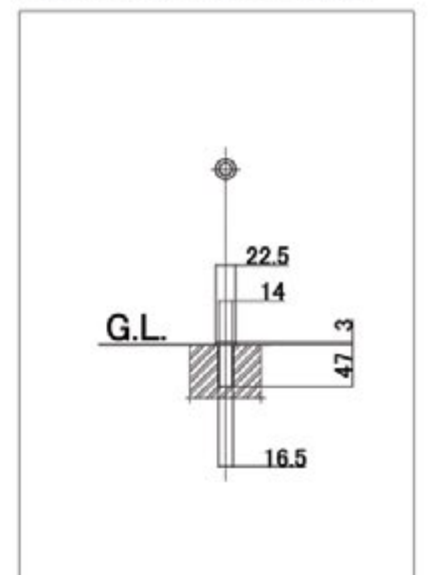

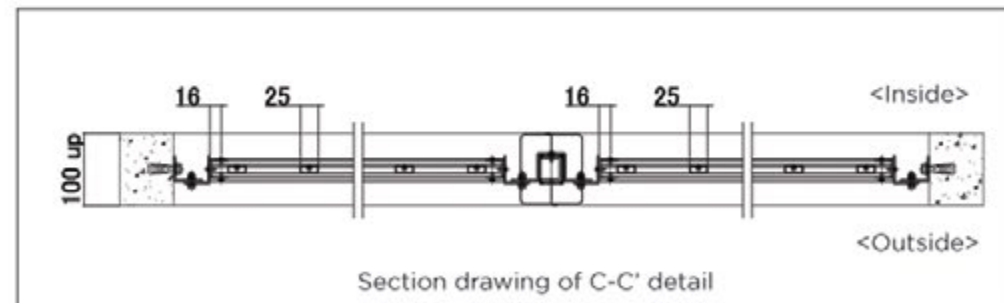
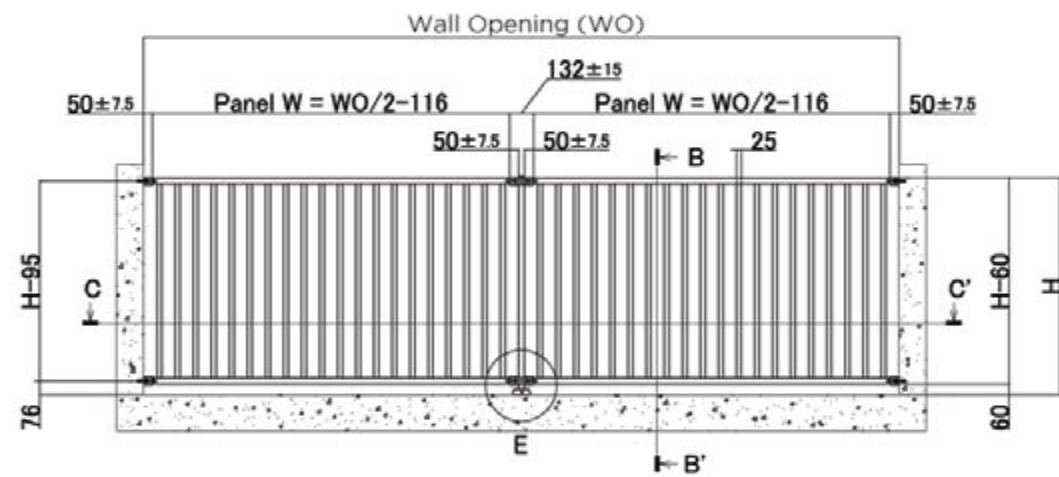
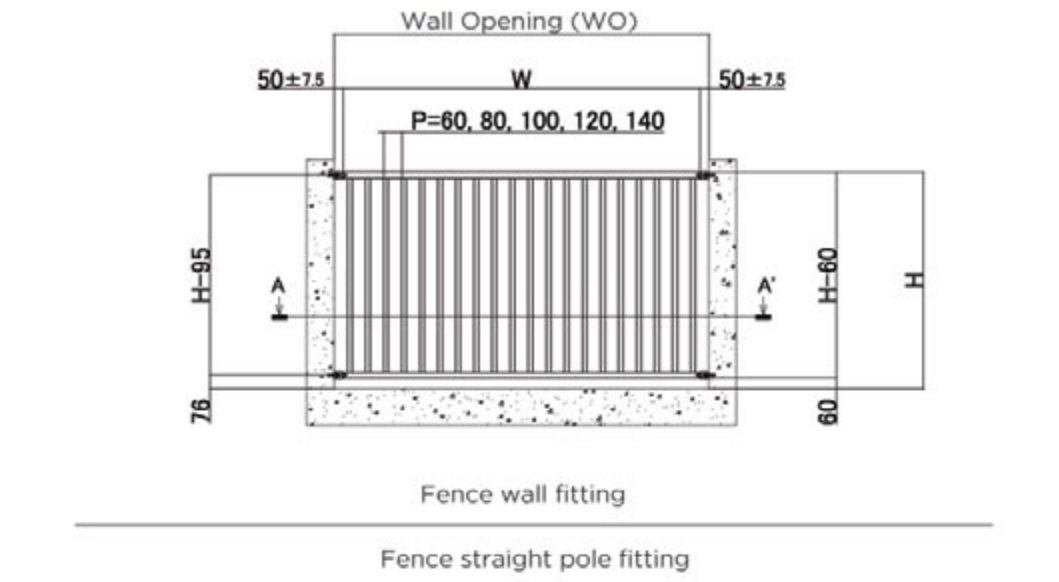
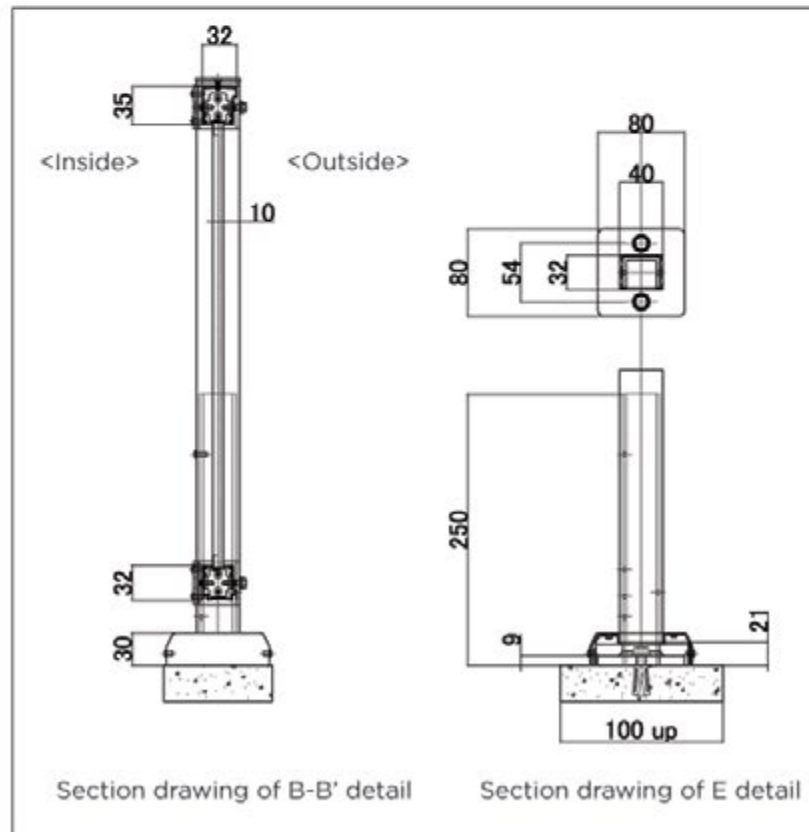
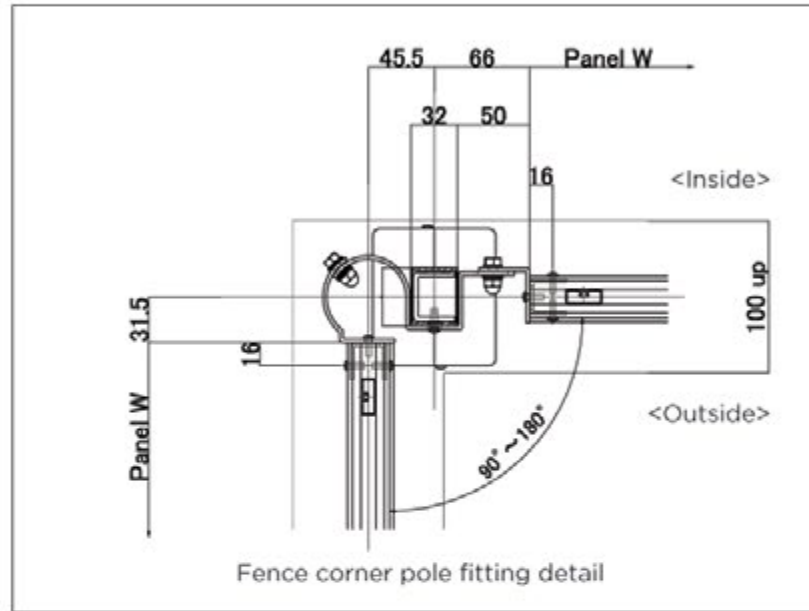
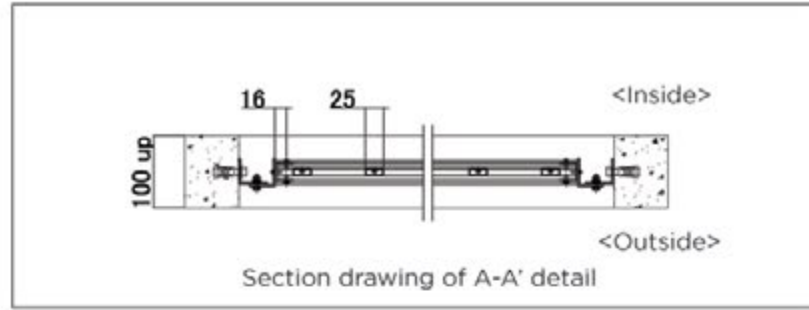





**PROJECT REFERENCE**  
MALTON GATES, THAILAND





**PROJECT REFERENCE**  
PRIVATE HOUSE, INDONESIA



# TOSTEM

LIXIL WINDOW SYSTEMS PRIVATE LIMITED (INDIA)  
[www.tostemindia.com](http://www.tostemindia.com)

LHT ASIA SALES & MARKETING CO., LTD. (THAILAND)  
[www.tostemthailand.com](http://www.tostemthailand.com)

PT. LIXIL ALUMINUM INDONESIA (INDONESIA)  
[www.tostemindonesia.com](http://www.tostemindonesia.com)

LIXIL VIETNAM CORPORATION (VIETNAM)  
[www.tostemvietnam.com](http://www.tostemvietnam.com)

PART OF **LIXIL**

LIXIL PHILIPPINES CO., LTD. (PHILIPPINES)  
[www.tostemphilippines.com](http://www.tostemphilippines.com)